

Operator's Manual

ZAXIS

30

35

40

50

Excavator

Serial No.

ZAXIS30 001001 and up

ZAXIS35 001002 and up

ZAXIS40 002001 and up

ZAXIS50 002002 and up

HITACHI

INTRODUCTION

Read this manual carefully to learn how to operate and service your machine correctly. Failure to do so could result in personal injury or equipment damage.

This manual should be considered a permanent part of your machine and should remain with the machine when you sell it.

This machine is of metric design. Measurements in this manual are metric. Use only metric hardware and tools as specified.

- SI Units (International System of Units) are used in this manual.

For reference MKS system units and English units are also indicated in parentheses after the SI units. Example : 25.0 MPa (250 kgf/cm², 3560 psi)

Right-hand and left-hand sides are determined by facing in the direction of forward travel.

Write product identification numbers in the Machine Numbers section. Accurately record all the numbers to help in tracing the machine should it be stolen. Your dealer also needs these numbers when you order parts. If this manual is kept on the machine, also file the identification numbers in a secure place off the machine.

Warranty is provided as a part of Hitachi's support program for customers who operate and maintain their equipment as described in this manual. The warranty is explained on the warranty certificate which you should have received from your dealer.

This warranty provides you the assurance that Hitachi will back its products where defects appear within the warranty period. In some circumstances, Hitachi also provides field improvements, often without charge to the customer, even if the product is out of warranty. Should the equipment be abused, or modified to change its performance beyond the original factory specifications, the warranty will become void and field improvements may be denied. Setting fuel delivery above specifications or otherwise overpowering machines will result in such action.

Prior to operating this machine in a country other than a country of its intended use, it may be necessary to make modifications to it so that it complies with the local standards (including safety standards) and requirements of that particular country. Please do not operate this machine outside of the country of its intended use until such compliance has been confirmed.

Please contact Hitachi Construction Machinery Co., Ltd. or any of our authorized distributor or dealer if you have any questions concerning compliance.

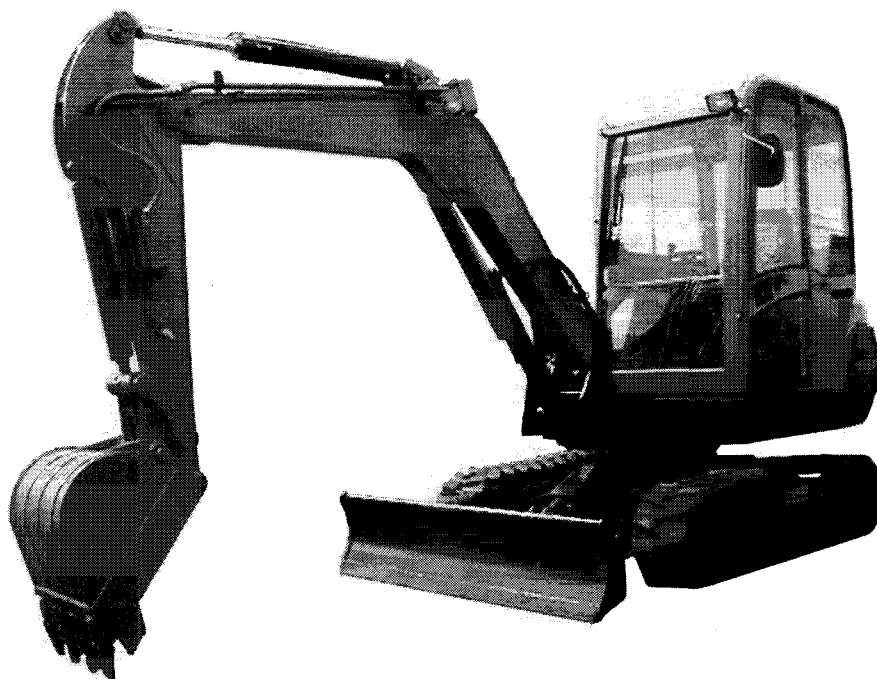

All information, illustrations and specifications in this manual are based on the latest product information available at the time of publication. The right is reserved to make changes at any time without notice.

INDEX

MACHINE NUMBERS

SAFETY

SAFETY SIGNS

COMPONENTS NAME

OPERATOR'S STATION

BREAK-IN

OPERATING THE ENGINE

DRIVING THE MACHINE

OPERATING THE MACHINE

TRANSPORTING

MAINTENANCE

STORAGE

TROUBLESHOOTING

SPECIFICATIONS

INDEX

CONTENTS

MACHINE NUMBERS

SAFETY

Recognize Safety Information	S1
Understand Signal Words	S1
Follow Safety Instructions	S2
Prepare for Emergencies	S2
Wear Protective Clothing	S3
Protect Against Noise	S3
Inspect Machine	S3
Use Handholds and Steps	S4
Adjust the Operator's Seat	S4
Fasten Your Seat Belt	S5
Move and Operate Machine Safely	S5
Operate Only from Operator's Seat	S6
Jump Starting	S6
Keep Riders Off Machine	S6
Investigate Job Site Beforehand	S7
Protect Against Falling Stones and Debris	S7
Provide Signals for Jobs Involving Multiple Numbers of Machines	S8
Confirm Direction of Machine to be Driven	S8
Drive Machine Safely	S9
Avoid Injury from Rollaway Accidents	S10
Avoid Injury from Back-Over and Swing Accidents	S11
Keep Person Clear from Working Area	S12
Never Position Bucket Over Anyone	S12
Avoid Undercutting	S12
Avoid Tipping	S13
Never Undercut a High Bank	S13
Dig with Caution	S14
Operate with Caution	S14
Avoid Power Lines	S14
Do Not Use for Craning Operation	S15
Protect Against Flying Debris	S15
Park Machine Safely	S15
Handle Fluids Safely – Avoid Fires	S16
Safety Transporting	S17
Practice Safe Maintenance	S18
Support Machine Properly	S19
Stay Clear of Moving Parts	S19
Warn Others of Service Work	S19
Prevent Parts from Flying	S20
Store Attachments Safely	S20
Prevent Burns	S21
Replace Rubber Hoses Periodically	S21
Avoid High-Pressure Fluids	S22
Prevent Fires	S23
Evacuating in Case of Fire	S24
Beware of Exhaust Fumes	S24
Avoid Heating Near Pressurized Fluid Lines	S25
Avoid Applying Heat to Lines Containing Flammable Fluids	S25
Remove Paint before Welding or Heating	S25
Prevent Battery Explosions	S26

Handle Chemical Products Safely	S27
Dispose of Waste Properly	S27

SAFETY SIGNS	S28
---------------------------	-----

COMPONENTS NAME	1-1
------------------------------	-----

OPERATOR'S STATION

Pedals and Levers	1-2
Monitor Panel and Switch Panel	1-3
Key Switch	1-4
Work Light Switch	1-4
Monitor Panel	1-5
Alternator Indicator	1-5
Engine Oil Pressure Indicator	1-5
Preheat Indicator	1-6
Coolant Temperature Gauge and Overheat Indicator	1-6
Fuel Gauge and Fuel Level Indicator	1-7
Hour Meter	1-7
Cab Heater	1-8
Wiper/Washer Switch	1-8
Opening and Closing Front Window	1-9
Emergency Exit	1-10
Tool Box and Operator's Manual Box	1-11
Cab Door Release Button	1-11
Cab Light	1-11
Adjusting the Operator's Seat	1-12
Seat Belt	1-13

BREAK-IN

Breaking in a New Machine	2-1
Correct Break-In Procedures	2-1

OPERATING THE ENGINE

Before Starting Engine	3-1
Engine Speed Control Lever	3-1
Starting the Engine	3-2
Check Instruments after Starting	3-2
Using Booster Batteries	3-3
Stopping the Engine	3-4

DRIVING THE MACHINE

Travel Levers	4-1
Fast Speed Travel Pedal	4-2
Traveling	4-3
Operating on Soft Ground	4-4
Raise One Track Using Boom and Arm	4-4
Towing Machine a Short Distance	4-5
Operating in Water or Mud	4-6
Precautions for Traveling on Slopes	4-7
Parking and Stopping on a Slope	4-8
Parking the Machine	4-8

CONTENTS

OPERATING THE MACHINE

Control Lever (ISO Excavator Pattern)	5-1
Boom-Swing Pedal	5-2
Optional Pedal	5-3
Blade Lever	5-4
Pilot Control Shut-Off Lever	5-5
Warming Up Operation	5-7
Warming Up in Cold Weather	5-7
Precautions for Operations	5-8
Avoid Tipping	5-9
Operating Backhoe	5-10
Take Care Not to Hit the Bucket Teeth	5-10
Grading Operation	5-11
Avoid Abusive Operation	5-11
Select Correct Track Shoes	5-12
Operating Tips	5-12
Object Handling --- If Equipped	5-13
Avoid Hitting Blade with Front Attachment	5-14
Avoid Hitting Blade with Bucket	5-14
Avoid Striking the Blade into a Rock	5-14
Boom Cylinder May Hit Track	5-15
Precautions for Installing Wide Bucket or Special Type Bucket	5-15
Operate the Machine Safely	5-16
Using Rubber Crawler	5-17
Traveling and Other Cautions	5-18
Emergency Stop Procedure to Lower Front Attachment	5-19
Hydraulic Breaker Operating Tips	5-20
Replacement of Hydraulic Oil and Filter Element	5-22
Operating Hydraulic Crusher --- If Equipped	5-23
After Finishing Work	5-24

TRANSPORTING

Transporting by Road	6-1
Transporting the Machine by Truck	6-1
Precautions for Transporting Machines with Rubber Tracks	6-3
Lifting the Entire Machine with a Crane	6-5

MAINTENANCE

Correct Maintenance and Inspection Procedures	7-1
Service Your Machine at Specified Intervals	7-2
Check the Hour Meter Regularly	7-2
Prepare Machine for Maintenance	7-3
Hood and Access Covers	7-4
Daily Inspection	7-5
Daily Inspection Check List	7-6
Periodic Replacement of Parts	7-7
Maintenance Guide	7-8
The Brand Names of Recommended Oils and Lubricants	7-10
A. Greasing	7-11
Front Joint Pins	7-11

Bucket and Link Pins	7-13
Precautions for Front Attachment and Blade Removal	7-13
Swing Bearing	7-14
Swing Internal Gear	7-15
Control Lever Universal Joint	7-16
B. Engine	7-17
Engine Oil Level	7-17
Change Engine Oil	7-18
Replace Engine Oil Filters	7-18
C. Transmission	7-20
D. Hydraulic System	7-22
Inspection and Maintenance of Hydraulic Equipment	7-22
Check Hydraulic Oil Level	7-23
Drain Hydraulic Tank Sump	7-24
Change Hydraulic Oil	7-25
Clean Suction Filter	7-25
Increase Air Pressure in Hydraulic Oil Tank	7-28
Replace Hydraulic Oil Tank Filter	7-29
Replace Pilot Oil Filter	7-30
Check Hoses and Lines	7-31
E. Fuel System	7-37
Drain Fuel Tank Sump	7-38
Check Water Separator	7-38
Replace Fuel Filter	7-39
Check Fuel Hoses	7-40
F. Air Cleaner	7-41
Clean the Air Cleaner Element	7-41
G. Cooling System	7-42
Check Coolant Level	7-43
Check and Adjust Fan Belt Tension	7-44
Change Coolant	7-45
Clean Radiator	7-46
H. Electrical System	7-47
Batteries	7-47
Replacing Fuses	7-51
Electrical Socket	7-51
I. Miscellaneous	7-52
Check Bucket Teeth	7-52
Replace Bucket	7-53
Check Track Sag (rubber crawler)	7-54
Replace Rubber Track	7-56
Check Track Sag (steel crawler)	7-57
Check and Replace Seat Belt	7-60
Check Fuel Injection Nozzles	7-60
Check and Adjust Valve Clearance	7-60
Check Injection Timing	7-61
Measure Engine Compression pressure	7-61
Check Starter and Alternator	7-61
Check Radiator Cap	7-61
Check Tightening Torque of Bolts and Nuts	7-62
Often-Replaced Parts	7-65
Maintenance Under Special Environmental Conditions	7-66

CONTENTS

STORAGE

Storing the Machine	10-1
Removing the Machine From Storage	10-2

TROUBLESHOOTING

Troubleshooting	11-1
-----------------------	------

SPECIFICATIONS

Specifications	12-1
Working Ranges	12-3
Shoe Types and Applications	12-5
Bucket Types and Applications	12-9
Noise Level Results (89/514/EEG)	12-11
Special Specification (Optional)	12-12

INDEX	14-1
--------------------	------

MACHINE NUMBERS

The manufacturing Nos.explained in this group is the individual number (serial No.)given to each machine and hydraulic components.These numbers are requested when inquiring any information on the machine and/or components.Fill these serial Nos.in the blank spaces in this group to immediately make them available upon request.

MACHINE

MODEL/TYPE: _____

PRODUCT IDENTIFICATION NUMBER: _____

PRODUCT IDENTIFICATION NUMBER (PIN)

PRODUCT IDENTIFICATION NUMBER: _____

NOTE:

HCM1LS00000001001 Marks to indicate the start and end of the PIN

PRODUCT IDENTIFICATION NUMBER (PIN)

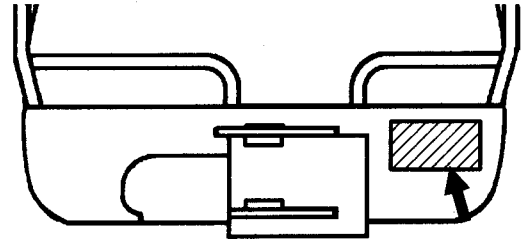

M503-12-001

ENGINE

TYPE: _____

MGF.NO.: _____

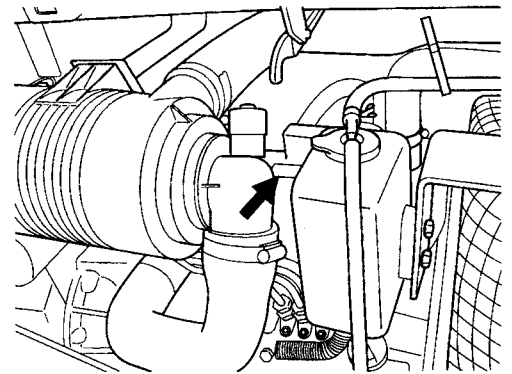

ZAXIS30, 35

M1LS-00-005

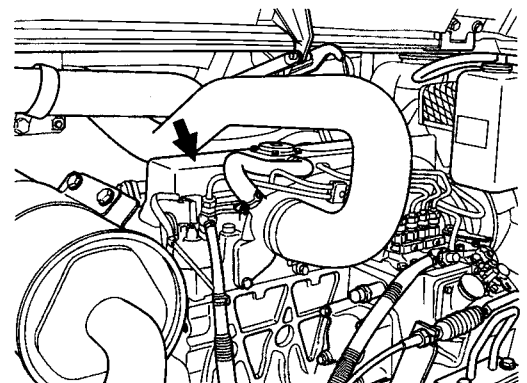

ZAXIS40, 50

M1LS-00-002

MACHINE NUMBERS

TRAVEL MOTOR

TYPE: _____
MGF.NO.: _____

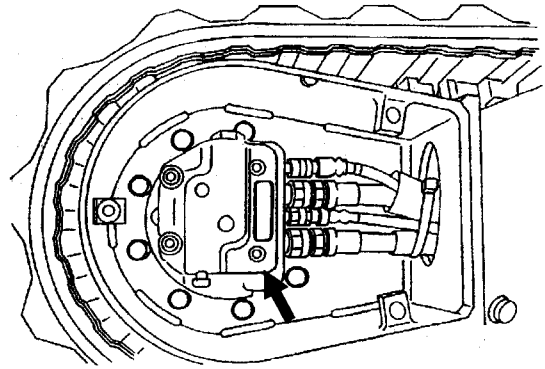

M503-12-003

HYDRAULIC PUMP

TYPE: _____
MGF.NO.: _____

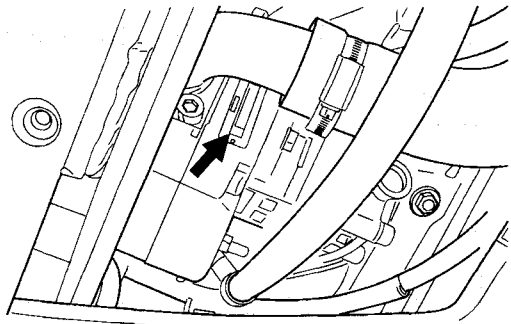

ZAXIS30, 35

M1LS-00-003

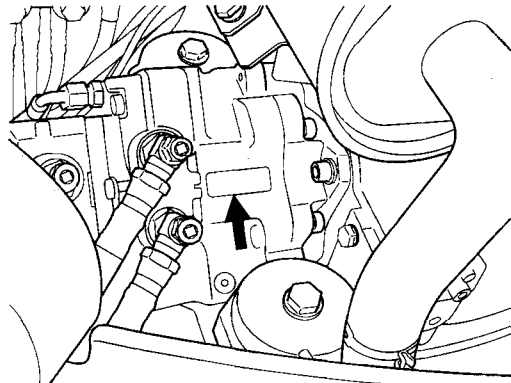

ZAXIS40, 50

M1LS-00-004

SAFETY

RECOGNIZE SAFETY INFORMATION

- This is the **SAFETY ALERT SYMBOL**.
 - When you see this symbol on your machine or in this manual, be alert to the potential for personal injury.
 - Follow recommended precautions and safe operating practices.



001-E01A-0001-2

SA-001

UNDERSTAND SIGNAL WORDS

- On machine safety signs, signal words designating the degree or level of hazard - **DANGER**, **WARNING**, or **CAUTION** - are used with the safety alert symbol.
 - **DANGER** indicates an imminently hazardous situation which, if not avoided, will result in death or serious injury.
 - **WARNING** indicates a potentially hazardous situation which, if not avoided, could result in death or serious injury.
 - **CAUTION** indicates a potentially hazardous situation which, if not avoided, may result in minor or moderate injury.
 - **DANGER** or **WARNING** safety signs are located near specific hazards. General precautions are listed on **CAUTION** safety signs.
- **CAUTION** also calls attention to safety messages in this manual.
- To avoid confusing machine protection with personal safety messages, a signal word **IMPORTANT** indicates a situation which, if not avoided, could result in damage to the machine.
-  **NOTE** indicates an additional explanation for an element of information.



IMPORTANT



002-E01A-0461-6

SA-1223

SAFETY

FOLLOW SAFETY INSTRUCTIONS

- Carefully read and follow all safety signs on the machine and all safety messages in this manual.
- Safety signs should be installed, maintained and replaced when necessary.
 - If a safety sign or this manual is damaged or missing, order a replacement from your authorized dealer in the same way you order other replacement parts (be sure to state machine model and serial number when ordering).
- Learn how to operate the machine and its controls correctly and safely.
- Allow only trained, qualified, authorized personnel to operate the machine.
- Keep your machine in proper working condition.
 - Unauthorized modifications of the machine may impair its function and/or safety and affect machine life.
- The safety messages in this SAFETY chapter are intended to illustrate basic safety procedures of machines. However it is impossible for these safety messages to cover every hazardous situation you may encounter. If you have any questions, you should first consult your supervisor before operating or performing maintenance work on the machine.

003-E01A-0003-5

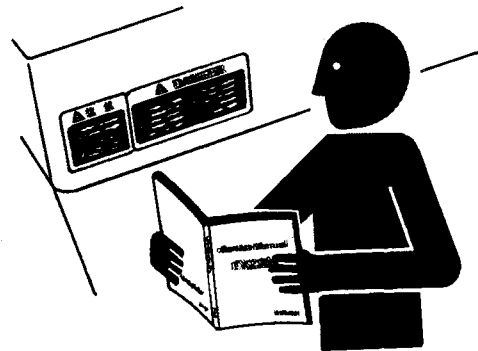

SA-003

PREPARE FOR EMERGENCIES

- Be prepared if a fire starts or if an accident occurs.
 - Keep a first aid kit and fire extinguisher on hand.
 - Thoroughly read and understand the label attached on the fire extinguisher to use it properly.
 - Establish emergency procedure guidelines to cope with fires and accidents.
 - Keep emergency numbers for doctors, ambulance service, hospital, and fire department posted near your telephone.

004-E01A-0437-3

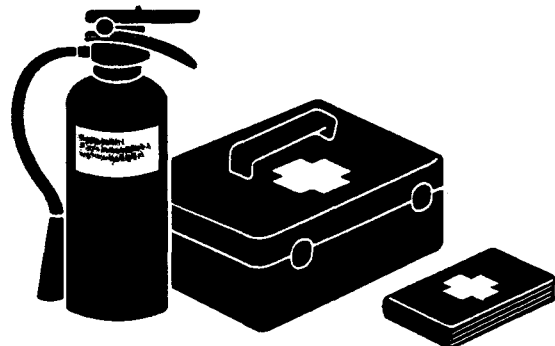

SA-437

SAFETY

WEAR PROTECTIVE CLOTHING

- Wear close fitting clothing and safety equipment appropriate to the job.

You may need:

- A hard hat
- Safety shoes
- Safety glasses, goggles, or face shield
- Heavy gloves
- Hearing protection
- Reflective clothing
- Wet weather gear
- Respirator or filter mask.

Be sure to wear the correct equipment and clothing for the job. Do not take any chances.

- Avoid wearing loose clothing, jewelry, or other items that can catch on control levers or other parts of the machine.
- Operating equipment safely requires the full attention of the operator. Do not wear radio or music headphones while operating the machine.

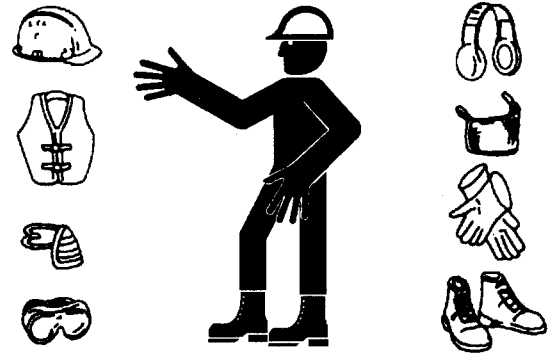

SA-438

005-E01A-0438-4

PROTECT AGAINST NOISE

- Prolonged exposure to loud noise can cause impairment or loss of hearing.
- Wear a suitable hearing protective device such as earmuffs or earplugs to protect against objectionable or uncomfortably loud noises.



SA-434

006-E01A-0434-2

INSPECT MACHINE

- Inspect your machine carefully each day or shift by walking around it before you start it to avoid personal injury.
- In the walk-around inspection, be sure to cover all points described in the "PRE-START INSPECTION" chapter.



007-E01A-0435-2

SA-435

SAFETY

USE HANDHOLDS AND STEPS

- Falling is one of the major causes of personal injury.
 - When you get on and off the machine, always face the machine and maintain a three-point contact with the steps and handrails.
 - Do not use any controls as handholds.
 - Never jump on or off the machine. Never mount or dismount a moving machine.
 - Be careful of slippery conditions on platforms, steps, and handrails when leaving the machine.

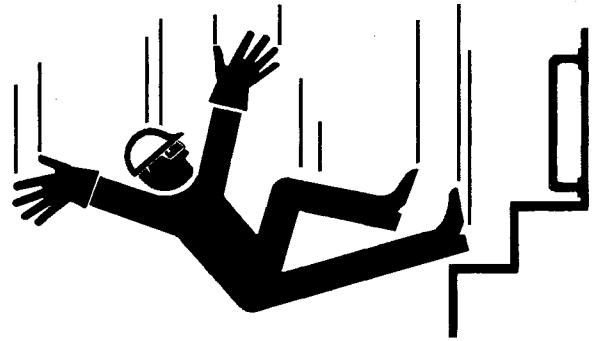

SA-439

008-E01A-0439-3

ADJUST THE OPERATOR'S SEAT

- A poorly adjusted seat for either the operator or for the work at hand may quickly fatigue the operator leading to misoperations.
 - The seat should be adjusted whenever changing the operator for the machine.
 - The operator should be able to fully depress the pedals and to correctly operate the control levers with his back against the seat back.
 - If not, move the seat forward or backward, and check again.



SA-378

009-E01A-0378-3

SAFETY

FASTEN YOUR SEAT BELT

- If the machine should overturn, the operator may become injured and/or thrown from the cab. Additionally the operator may be crushed by the overturning machine, resulting in serious injury or death.
- Prior to operating the machine, thoroughly examine webbing, buckle and attaching hardware. If any item is damaged or worn, replace the seat belt or component before operating the machine.
- Be sure to remain seated with the seat belt securely fastened at all times when the machine is in operation to minimize the chance of injury from an accident.

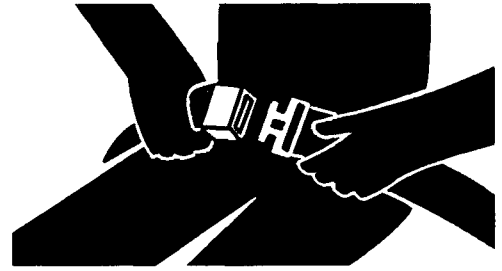

SA-237

010-E02A-0237-3

MOVE AND OPERATE MACHINE SAFELY

- Bystanders can be run over.
- Take extra care not to run over bystanders. Confirm the location of bystanders before moving, swinging, or operating the machine.
- Always keep the travel alarm and horn in working condition (if equipped). It warns people when the machine starts to move.
- Use a signal person when moving, swinging, or operating the machine in congested areas. Coordinate hand signals before starting the machine.

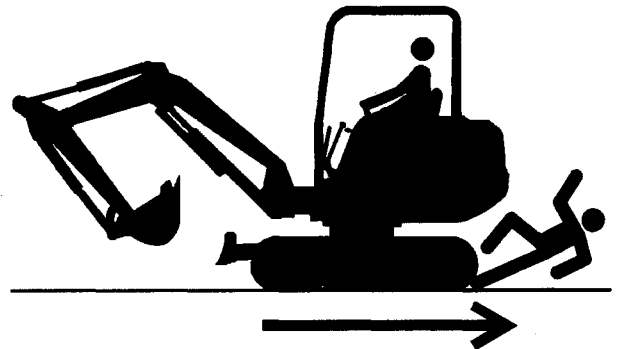

SA-659

011-E01A-0529-4

SAFETY

OPERATE ONLY FROM OPERATOR'S SEAT

- Inappropriate engine starting procedure may cause the machine to runaway, possibly resulting in serious injury or death.
- Start the engine only from the operator's seat.
- NEVER start the engine while standing on the track or on ground.
- Do not start engine by shorting across starter terminals.
- Before starting the engine, confirm that all control levers are in neutral.



SA-444

012-E01A-0444-3

JUMP STARTING

- Battery gas can explode, resulting in serious injury.
- If the engine must be jump started, be sure to follow the instructions shown in the "OPERATING THE ENGINE" chapter.
- The operator must be in the operator's seat so that the machine will be under control when the engine starts. Jump starting is a two-person operation.
- Never use a frozen battery.
- Failure to follow correct jump starting procedures could result in a battery explosion or a runaway machine.

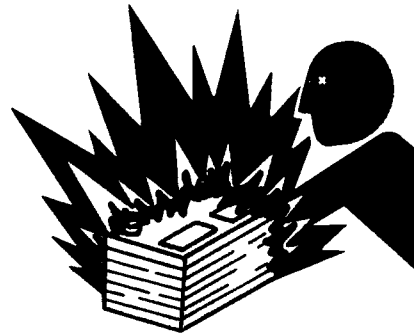

SA-032

013-E01A-0032-3

KEEP RIDERS OFF MACHINE

- Riders on machine are subject to injury such as being struck by foreign objects and being thrown off the machine.
- Only allow the operator on the machine. Keep riders off.
- Riders also obstruct the operator's view, resulting in the machine being operated in an unsafe manner.

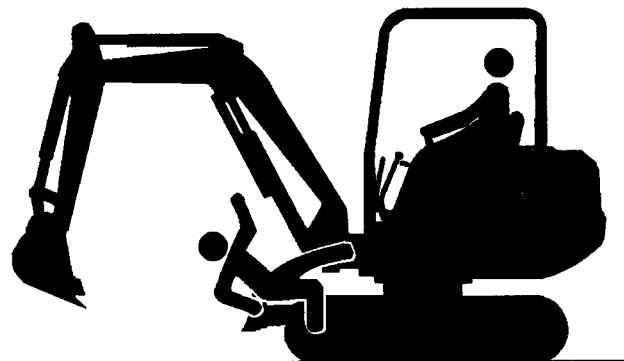

014-E01A-0530-2

SA-660

SAFETY

INVESTIGATE JOB SITE BEFOREHAND

- When working at the edge of an excavation or on a road shoulder, the machine could tip over, possibly resulting in serious injury or death.
- Investigate the configuration and ground conditions of the job site beforehand to prevent the machine from falling and to prevent the ground, stockpiles, or banks from collapsing.
- Make a work plan. Use machines appropriate to the work and job site.
- Reinforce ground, edges, and road shoulders as necessary. Keep the machine well back from the edges of excavations and road shoulders.
- When working on an incline or on a road shoulder, employ a signal person as required.
- Confirm that your machine is equipped a FOPS cab before working in areas where the possibility of falling stones or debris exist.
- When the footing is weak, reinforce the ground before starting work.
- When working on frozen ground, be extremely alert. As ambient temperatures rise, footing becomes loose and slippery.



SA-661

015-E01A-0531-5

PROTECT AGAINST FALLING STONES AND DEBRIS

- Confirm that your machine is FOPS cab equipped before working in areas where the possibility of falling stones or debris exist.

016-E01A-0510-2

SAFETY

PROVIDE SIGNALS FOR JOBS INVOLVING MULTIPLE NUMBERS OF MACHINES

- For jobs involving multiple numbers of machines, provide signals commonly known by all personnel involved. Also, appoint a signal person to coordinate the job site. Make sure that all personnel obey the signal person's directions.



018-E01A-0481-2

SA-481

CONFIRM DIRECTION OF MACHINE TO BE DRIVEN

- Incorrect travel pedal/lever operation may result in serious injury death.
- Before driving the machine, confirm the position of the undercarriage in relation to the operator's position. If the travel motors are located in front of the cab, the machine will move in reverse when travel pedals/levers are operated to the front.

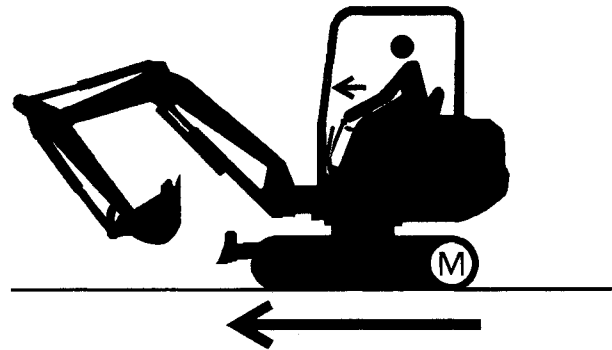

017-E01A-0532-2

SA-662

SAFETY

DRIVE MACHINE SAFELY

- Before moving the machine, confirm which way to move travel pedals/levers for the corresponding direction you wish to go.
 - Pushing the travel levers forward moves the machine towards the idlers. (Refer to the Driving the Machine "Travel Levers" section for correct travel operation.)
- Traveling on a grade may cause the machine to slip or to overturn, possibly resulting in serious injury or death.
 - When traveling up or down a grade, keep the bucket in the direction of travel, approximately 0.2 to 0.3 m (8 to 12 in) (A) above the ground.
 - If machine starts to skid or becomes unstable, lower the bucket immediately.
- Traveling across the face of slope or steering on a slope may cause the machine to skid or to turnover. If the direction must be changed, move the machine to level ground, then, change the direction to ensure safe operation.

019-E02A-0547-8

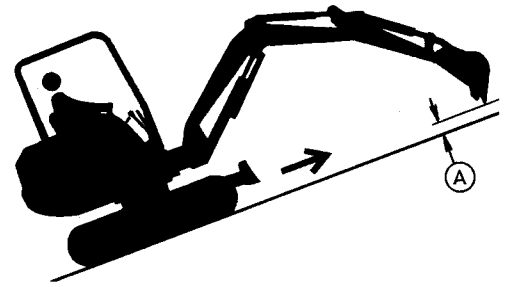

SA-663

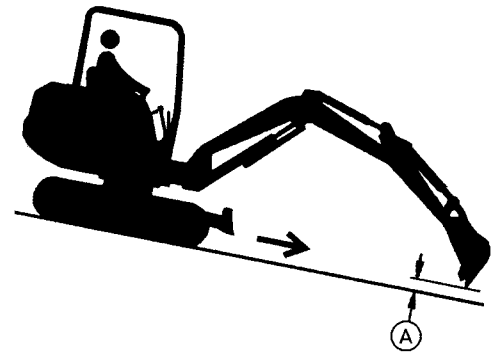

SA-664

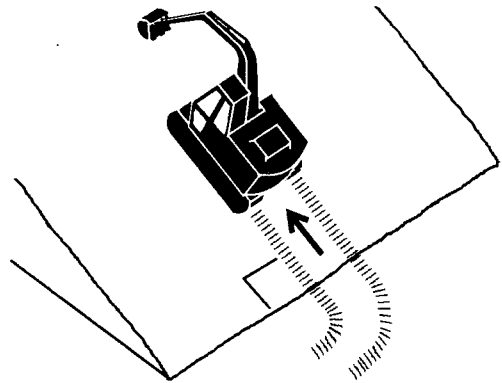

SA-441

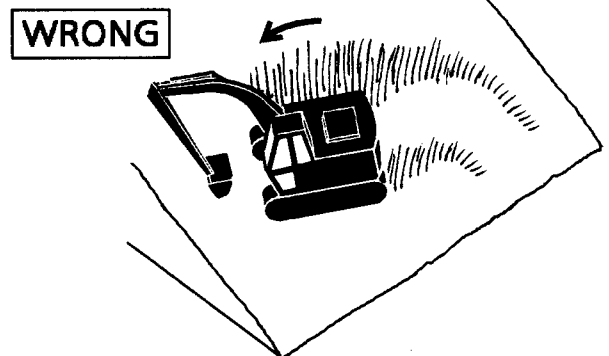

SA-442

SAFETY

AVOID INJURY FROM ROLLAWAY ACCIDENTS

- Death or serious injury may result if you attempt to mount or stop a moving machine.

To avoid rollaways:

- Select level ground when possible to park machine.
- Do not park the machine on a grade.
- Lower the bucket to the ground.
- Run the engine at slow idle speed without load for 5 minutes to cooling it.
- Stop the engine and remove the key from the key switch.
- Pull the pilot controls shut-off lever to LOCK position.
- Block both tracks and lower the bucket to the ground, thrust the bucket teeth into the ground if you must park on a grade.
- Position the machine to prevent rolling.
- Park a reasonable distance from other machines.

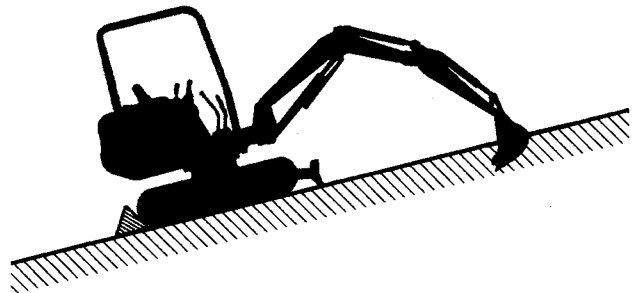
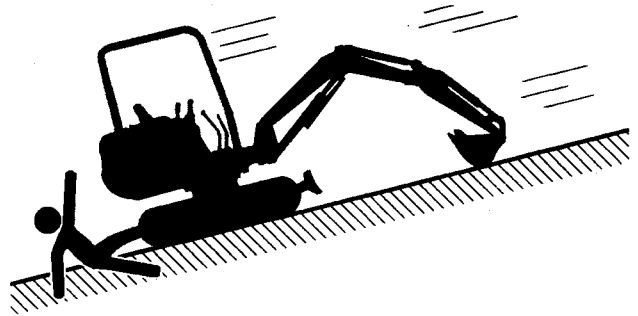

SA-666

020-E01A-0548-4

SAFETY

AVOID INJURY FROM BACK-OVER AND SWING ACCIDENTS

- If any person is present near the machine when backing or swinging the upperstructure, the machine may hit or run over that person, resulting in serious injury or death.

To avoid back-over and swing accidents:

- Always look around **BEFORE YOU BACK UP AND SWING THE MACHINE. BE SURE THAT ALL BYSTANDERS ARE CLEAR.**
- Keep the travel alarm in working condition (if equipped).
ALWAYS BE ALERT FOR BYSTANDERS MOVING INTO THE WORK AREA. USE THE HORN OR OTHER SIGNAL TO WARN BYSTANDERS BEFORE MOVING MACHINE.
- USE A SIGNAL PERSON WHEN BACKING UP IF YOUR VIEW IS OBSTRUCTED. ALWAYS KEEP THE SIGNAL PERSON IN VIEW.
Use hand signals, which conform to your local regulations, when work conditions require a signal person.
- No machine motions shall be made unless signals are clearly understood by both signalman and operator.
- Learn the meanings of all flags, signs, and markings used on the job and confirm who has the responsibility for signaling.
- Keep windows, mirrors, and lights clean and in good condition.
- Dust, heavy rain, fog, etc., can reduce visibility. As visibility decreases, reduce speed and use proper lighting.
- Read and understand all operating instructions in the operator's manual.

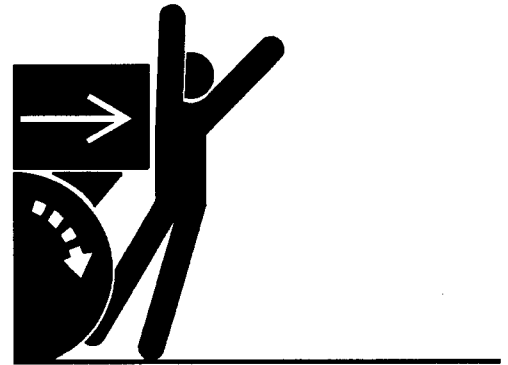

SA-383

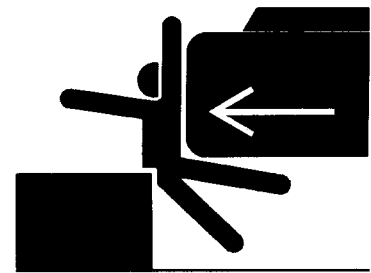

SA-384

021-E01A-0494-8

SAFETY

KEEP PERSON CLEAR FROM WORKING AREA

- A person may be hit severely by the swinging front attachment or counterweight and/or may be crushed against an other object, resulting in serious injury or death.
- Keep all persons clear from the area of operation and machine movement.
- Before operating the machine, set up barriers to the sides and rear area of the bucket swing radius to prevent anyone from entering the work area.

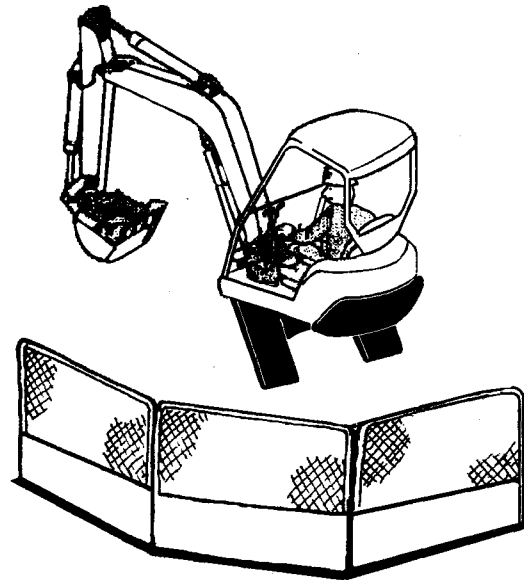

022-E01A-0537-3

SA-667

NEVER POSITION BUCKET OVER ANYONE

- Never lift, move, or swing bucket above anyone or a truck cab. Serious injury or machine damage may result due to bucket load spill or due to collision with the bucket.



SA-668

023-E01A-0538-2

AVOID UNDERCUTTING

- In order to retreat from the edge of an excavation if the footing should collapse, always position the undercarriage perpendicular to the edge of the excavation with the travel motors at the rear.
- If the footing starts to collapse and if retreat is not possible, do not panic. Often, the machine can be secured by lowering the front attachment, in such cases.

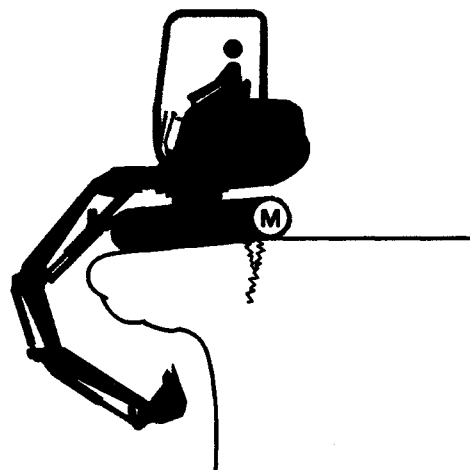

024-E01A-0539-2

SA-669

SAFETY

AVOID TIPPING

- The danger of tipping is always present when operating on a grade, possibly resulting in serious injury or death.

To avoid tipping:

- Be extra careful before operating on a grade.
 - Prepare machine operating area flat.
 - Keep the bucket low to the ground and close to the machine.
 - Reduce operating speeds to avoid tipping or slipping.
 - Avoid changing direction when traveling on grades.
 - Point the tracks uphill to avoid tipping.
 - NEVER attempt to travel across a grade steeper than 15 degrees if crossing the grade is unavoidable.
 - Reduce swing speed as necessary when swinging loads.
- Be careful when working on frozen ground.
 - Temperature increases will cause the ground to become soft and make ground travel unstable.

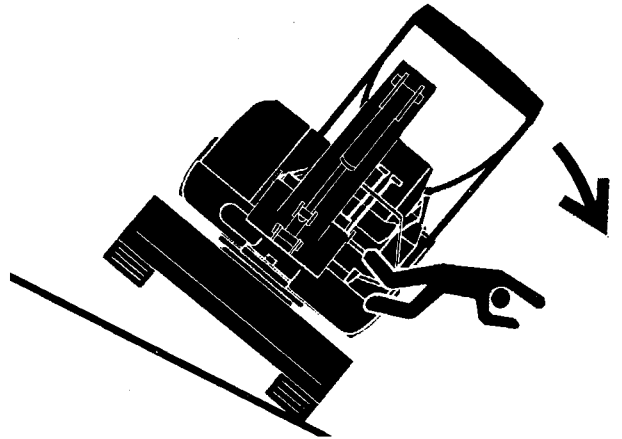

SA-670

025-E01A-0540-4

NEVER UNDERCUT A HIGH BANK

- The edges could collapse or a land slide could occur causing serious injury or death.

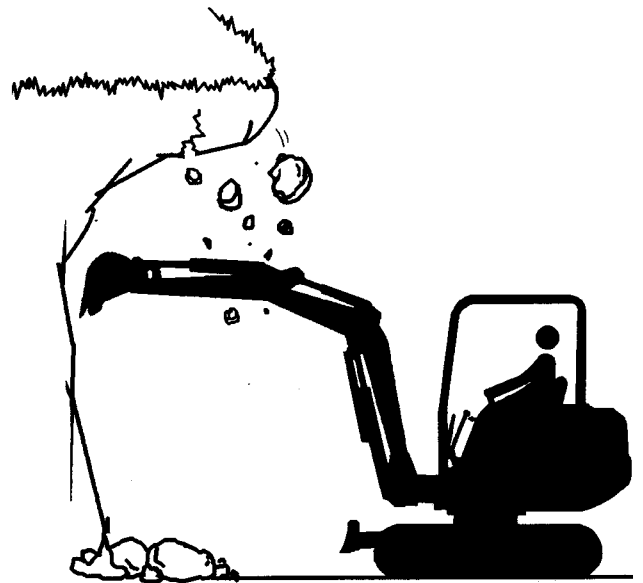

026-E01A-0541-2

SA-671

SAFETY

DIG WITH CAUTION

- Accidental severing of underground cables or gas lines may cause an explosion and/or fire, possibly resulting in serious injury or death.
- Before digging check the location of cables, gas lines, and water lines.
- Keep the minimum distance required, by law, from cables, gas lines, and water lines.
- If a fiber optic cable should be accidentally severed, do not look into the end. Doing so may result in serious eye injury.
- Contact your local "diggers hot line" if available in your area, and/or the utility companies directly. Have them mark all underground utilities.

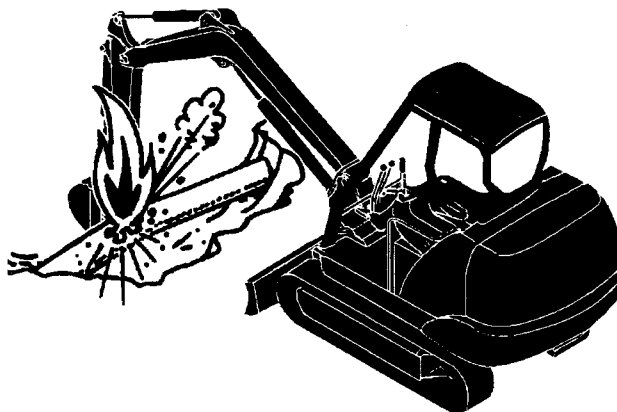

SA-672

027-E01A-0542-2

OPERATE WITH CAUTION

- If the front attachment or any other part of the machine hits against an overhead obstacle, such as a bridge, both the machine and the overhead obstacle will be damaged, and personal injury may result as well.
- Take care to avoid hitting overhead obstacles with the boom or arm.

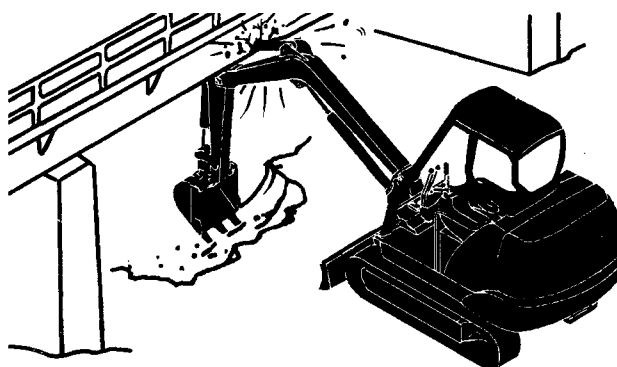

SA-673

028-E01A-0543-2

AVOID POWER LINES

- Serious injury or death can result if the machine or front attachments are not kept a safe distance from electric lines.
- When operating near an electric line, NEVER move any part of the machine or load closer than 3 m (10 ft) plus twice the line insulator length.
- Check and comply with any local regulations that may apply.
- Wet ground will expand the area that could cause any person on it to be affected by electric shock. Keep all bystanders or co-workers away from the site.

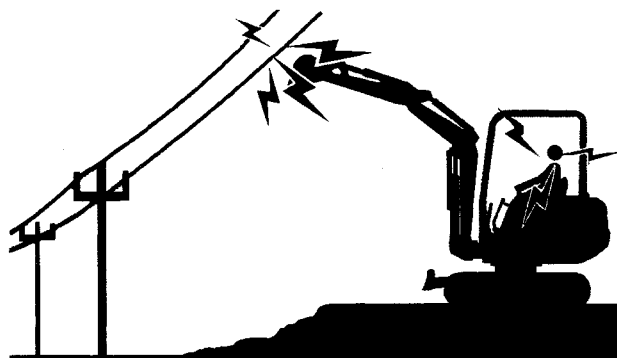

SA-674

029-E01A-0544-2

SAFETY

DO NOT USE FOR CRANING OPERATION

- This machine is not equipped with any devices that could allow the machine to be used for craning operation. If the machine is used for craning operation, the machine may tip over and/or lifted load may fall, possibly resulting in serious injury or death.
- NEVER use the machine for craning operation.

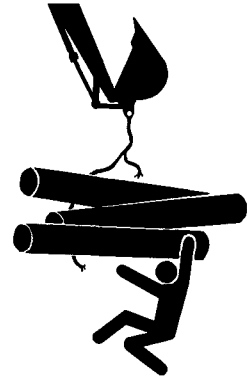

030-E01A-0014-2

SA-014

PROTECT AGAINST FLYING DEBRIS

- If flying debris hit eyes or any other part of the body, serious injury may result.
- Guard against injury from flying pieces of metal or debris; wear goggles or safety glasses.
- Keep bystanders away from the working area before striking any object.

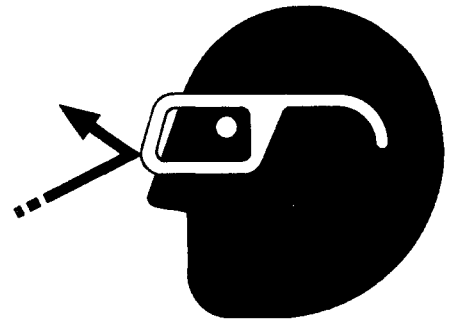

031-E01A-0432-2

SA-432

PARK MACHINE SAFELY

To avoid accidents:

- Park machine on a level surface.
- Lower bucket and blade to the ground.
- Run engine at slow idle speed without load for 5 minutes.
- Turn key switch to OFF to stop engine.
- Remove the key from the key switch.
- Pull the pilot control shut-off lever to the LOCK position.
- Close windows, roof vent, and cab door.
- Lock all access doors and compartments.



SA-675

033-E01A-0545-4

SAFETY

HANDLE FLUIDS SAFELY—AVOID FIRES

- Handle fuel with care; it is highly flammable. If fuel ignites, an explosion and/or a fire may occur, possibly resulting in serious injury or death.
 - Do not refuel the machine while smoking or when near open flame or sparks.
 - Always stop the engine before refueling the machine.
 - Fill the fuel tank outdoors.
- All fuels, most lubricants, and some coolants are flammable.
 - Store flammable fluids well away from fire hazards.
 - Do not incinerate or puncture pressurized containers.
 - Do not store oily rags; they can ignite and burn spontaneously.



SA-018



034-E01A-0496-4

SA-019

SAFETY

SAFETY TRANSPORTING

- The danger of tipping is present when loading/unloading the machine onto/from a truck or trailer bed.
- Be sure to observe local regulations when transporting the machine on public roads.
- Provide an appropriate truck or trailer for transporting the machine.

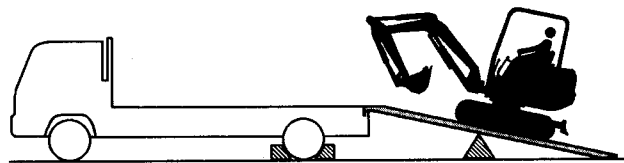

SA-676

Take the following precautions when loading/unloading the machine:

1. Select firm level ground.
2. Be sure to use a loading dock or ramp.
3. Ramps must be sufficient in width, length, and strength. Be sure that the incline of the ramp is less than 15 degrees.
4. Loading docks must be sufficient in width and strength to support the machine and have a gradient of less than 15 degrees.
5. Be sure to have a signal person when loading/unloading the machine.
6. Be sure to load/unload the machine at slow speed.
7. Avoid steering while driving up or down the ramp as it is extremely dangerous. If steering is unavoidable, first move back to the ground or flatbed, modify traveling direction, and begin to drive again.
8. Do not operate any levers besides the travel levers when driving up or down the ramp.
9. The top end of the ramp where it meets the flatbed is a sudden bump. Take care when traveling over it.
10. Prevent possible injury from machine tipping while the upperstructure is rotating.
11. Keep the arm tucked under and rotate the upperstructure slowly for best stability.
12. Securely fasten chain or cables to the machine frame. Refer to "transporting" chapter in this manual for details.

035-E01A-0546-6

SAFETY

PRACTICE SAFE MAINTENANCE

To avoid accidents:

- Understand service procedures before doing work.
- Keep the work area clean and dry.
- Do not spray water or steam inside cab.
- Never lubricate or service the machine while it is moving.
- Keep hands, feet and clothing away from power-driven parts.

Before servicing the machine:

1. Park the machine on a level surface.
 2. Lower the bucket to the ground.
 3. Run the engine at slow idle speed without load for 5 minutes.
 4. Turn the key switch to OFF to stop engine.
 5. Relieve the pressure in the hydraulic system by moving the control levers several times.
 6. Remove the key from the switch.
 7. Attach a "Do Not Operate" tag on the control lever.
 8. Pull the pilot control shut-off lever to the LOCK position.
 9. Allow the engine to cool.
-
- If a maintenance procedure must be performed with the engine running, do not leave machine unattended.
 - If the machine must be raised, maintain a 90 to 110° angle between the boom and arm. Securely support any machine elements that must be raised for service work.
 - Never work under a machine raised by the boom.
 - Inspect certain parts periodically and repair or replace as necessary. Refer to the section discussing that part in the "MAINTENANCE" chapter of this manual.
 - Keep all parts in good condition and properly installed.
 - Fix damage immediately. Replace worn or broken parts. Remove any buildup of grease, oil, or debris.
 - Disconnect battery ground cable (-) before making adjustments to electrical systems or before welding on the machine.



SA-028



SA-527

500-E02A-0497-8

SAFETY

SUPPORT MACHINE PROPERLY

- Never attempt to work on the machine without securing the machine first.
- Always lower the attachment to the ground before you work on the machine.
- If you must work on a lifted machine or attachment, securely support the machine or attachment. Do not support the machine on cinder blocks, hollow tires, or props that may crumble under continuous load. Do not work under a machine that is supported solely by a jack.



SA-527

519-E01A-0527-3

STAY CLEAR OF MOVING PARTS

- Entanglement in moving parts can cause serious injury.
- To prevent accidents, care should be taken to ensure that hands, feet, clothing, jewelry and hair do not become entangled when working around rotating parts.

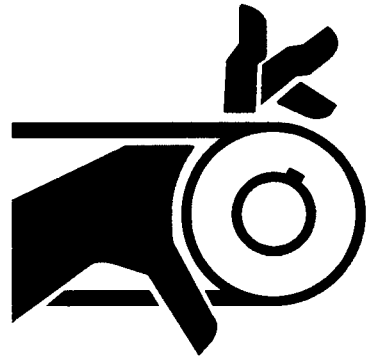

SA-026

502-E01A-0026-2

WARN OTHERS OF SERVICE WORK

- Unexpected machine movement can cause serious injury.
- Before performing any work on the machine, attach a "Do Not Operate" tag on the control lever. This tag is available from your authorized dealer.



502-E01A-0026-2

SS2045102

SAFETY

PREVENT PARTS FROM FLYING

- Grease in the track adjuster is under high pressure. Failure to follow the precautions below may result in serious injury, blindness, or death.
 - Do not attempt to remove GREASE FITTING or VALVE ASSEMBLY.
 - As pieces may fly off, be sure to keep body and face away from valve.
- Travel reduction gears are under pressure.
 - As pieces may fly off, be sure to keep body and face away from AIR RELEASE PLUG to avoid injury. GEAR OIL is hot. Wait for gear oil to cool, then gradually loosen the air release plug to release pressure.



SA-344

503-E01A-0344-4

STORE ATTACHMENTS SAFELY

- Stored attachments such as buckets, hydraulic hammers, and blades can fall and cause serious injury or death.
- Securely store attachments and implements to prevent falling. Keep children and bystanders away from storage areas.

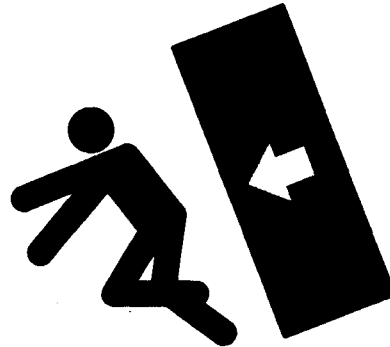

SA-034

504-E01A-0034-2

SAFETY

PREVENT BURNS

Hot spraying fluids:

- After operation, engine coolant is hot and under pressure. Hot water or steam is contained in the engine, radiator and heater lines. Skin contact with escaping hot water or steam can cause severe burns.
- To prevent possible injury from hot spraying water. DO NOT remove the radiator cap until the engine is cool. When opening, turn the cap slowly to the stop. Allow all pressure to be released before removing the cap.
- The hydraulic oil tank is pressurized. Again, be sure to release all pressure before removing the cap.

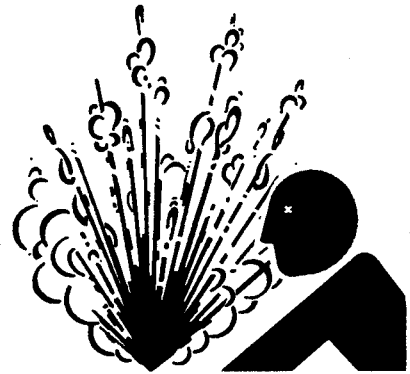

SA-039

Hot fluids and surfaces:

- Engine oil, gear oil and hydraulic oil also become hot during operation. The engine, hoses, lines and other parts become hot as well.
- Wait for the oil and components to cool before starting any maintenance or inspection work.



SA-225

505-E01A-0498-5

REPLACE RUBBER HOSES PERIODICALLY

- Rubber hoses that contain flammable fluids under pressure may break due to aging, fatigue, and abrasion. It is very difficult to gauge the extent of deterioration due to aging, fatigue, and abrasion of rubber hoses by inspection alone.
- Periodically replace the rubber hoses.
- Failure to periodically replace rubber hoses may cause a fire, fluid injection into skin, or the front attachment to fall on a person nearby, which may result in severe burns, gangrene, or otherwise serious injury or death.



SA-019

506-E01A-0019-3

SAFETY

AVOID HIGH-PRESSURE FLUIDS

- Fluids such as diesel fuel or hydraulic oil under pressure can penetrate the skin or eyes causing serious injury, blindness or death.
 - Avoid this hazard by relieving pressure before disconnecting hydraulic or other lines.
 - Relieve the pressure by moving the control levers several times.
Tighten all connections before applying pressure.
 - Search for leaks with a piece of cardboard; take care to protect hands and body from high-pressure fluids. Wear a face shield or goggles for eye protection.
 - If an accident occurs, see a doctor familiar with this type of injury immediately. Any fluid injected into the skin must be surgically removed within a few hours or gangrene may result.

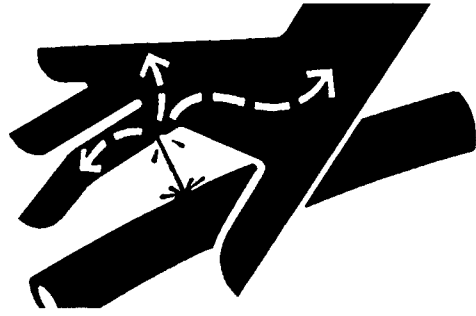

SA-031

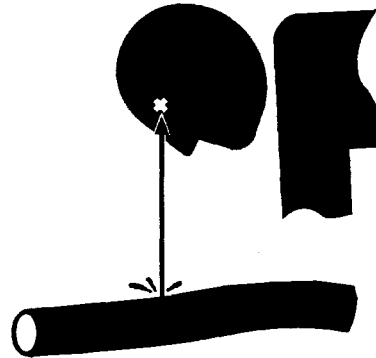

SA-292

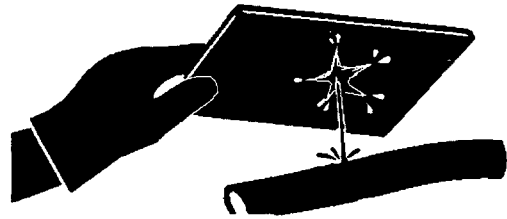

SA-044

507-E01A-0499-5

SAFETY

PREVENT FIRES

Check for Oil Leaks:

- Fuel, hydraulic oil and lubricant leaks can lead to fires.
 - Check for missing or loose clamps, kinked hoses, lines or hoses that rub against each other, damage to the oil-cooler, and loose oil-cooler flange bolts, for oil leaks.
 - Tighten, repair or replace any missing, loose or damaged clamps, lines, hoses, oil-cooler and oil-cooler flange bolts.
 - Do not bend or strike high-pressure lines.
 - Never install bent or damaged lines, pipes or hoses.



SA-019

Check for Shorts:

- Short circuits can cause fires.
 - Clean and tighten all electrical connections.
 - Check before each shift or after eight (8) to ten (10) hours operation for loose, kinked, hardened or frayed electrical cables and wires.
 - Check before each shift or after eight (8) to ten (10) hours operation for missing or damaged terminal caps.
 - **DO NOT OPERATE MACHINE** if cable or wires are loose, kinked, etc..

Clean up Flammables:

- Spilled fuel and oil, and trash, grease, debris, accumulated coal dust, and other flammables may cause fires.
 - Prevent fires by inspecting and cleaning the machine daily, and by removing spilled or accumulated flammables immediately.

Check Key Switch:

- If fire breaks out, failure to stop the engine will escalate fire, hampering fire fighting.
 - Always check key switch function before operating the machine every day:
 1. Start the engine and run it at slow idle.
 2. Turn the key switch to the OFF position to confirm that the engine stops.
 - If any abnormalities are found, be sure to repair them before operating the machine.

SAFETY

EVACUATING IN CASE OF FIRE

- If fire breaks out, evacuate the machine in the following way:
 - Stop the engine by turning the key switch to the OFF position if there is time.
 - Use a fire extinguisher if there is time.
 - Exit the machine.



SA-393

- In an emergency, if the cab door or front window can not be opened, break the front or rear window panes with the emergency evacuation hammer to escape from the cab.

Refer to the explanation pages on the Emergency Evacuation Method. (Cab-Equipped Machines Only)

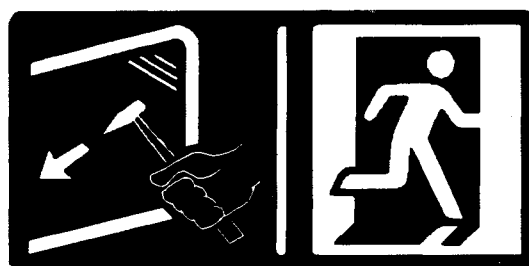

518-E02B-0393-2

SS-1510

BEWARE OF EXHAUST FUMES

- Prevent asphyxiation. Engine exhaust fumes can cause sickness or death.
 - If you must operate in a building, be sure there is adequate ventilation. Either use an exhaust pipe extension to remove the exhaust fumes or open doors and windows to bring enough outside air into the area.

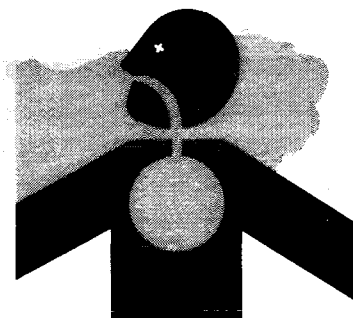

509-E01A-0016-2

SA-016

SAFETY

AVOID HEATING NEAR PRESSURIZED FLUID LINES

- Flammable spray can be generated by heating near pressurized fluid lines, resulting in severe burns to yourself and bystanders.
- Do not heat by welding, soldering, or using a torch near pressurized fluid lines or other flammable materials.
- Pressurized lines can be accidentally cut when heat goes beyond the immediate flame area. Install temporary fire resistant guards to protect hoses or other materials before engaging in welding, soldering, etc..



SA-030

AVOID APPLYING HEAT TO LINES CONTAINING FLAMMABLE FLUIDS

- Do not weld or flame cut pipes or tubes that contain flammable fluids.
- Clean them thoroughly with nonflammable solvent before welding or flame cutting them.

510-E01A-0030-4

REMOVE PAINT BEFORE WELDING OR HEATING

- Hazardous fumes can be generated when paint is heated by welding, soldering, or using a torch. If inhaled, these fumes may cause sickness.
- Avoid potentially toxic fumes and dust.
- Do all such work outside or in a well-ventilated area. Dispose of paint and solvent properly.
- Remove paint before welding or heating:
 1. If you sand or grind paint, avoid breathing the dust. Wear an approved respirator.
 2. If you use solvent or paint stripper, remove stripper with soap and water before welding. Remove solvent or paint stripper containers and other flammable material from area. Allow fumes to disperse at least 15 minutes before welding or heating.



SA-029

511-E01A-0029-4

SAFETY

PREVENT BATTERY EXPLOSIONS

- Battery gas can explode.
 - Keep sparks, lighted matches, and flame away from the top of battery.
 - Never check battery charge by placing a metal object across the posts. Use a voltmeter or hydrometer.
 - Do not charge a frozen battery; it may explode. Warm the battery to 16 °C (60 °F) first.
 - Do not continue to use or charge the battery when the electrolyte level is lower than specified. Explosion of the battery may result.
- Battery electrolyte is poisonous. If the battery should explode battery electrolyte may be splashed into eyes, possibly resulting in blindness.
 - Be sure to wear eye protection when checking electrolyte specific gravity.

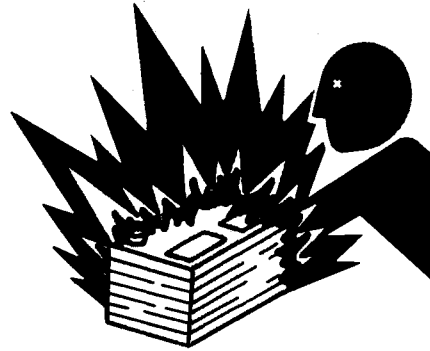

SA-032

512-E01A-0032-4

SAFETY

HANDLE CHEMICAL PRODUCTS SAFELY

- Direct exposure to hazardous chemicals can cause serious injury. Potentially hazardous chemicals used with your machine include such items as lubricants, coolants, paints, and adhesives.
- A Material Safety Data Sheet (MSDS) provides specific details on chemical products: physical and health hazards, safety procedures, and emergency response techniques.
- Check the MSDS before you start any job using a hazardous chemical. That way you will know exactly what the risks are and how to do the job safely. Then follow procedures and use recommended equipment.
- See your authorized dealer for MSDS' s (available only in English) on chemical products used with your machine.



SA-309

515-E01A-0309-4

DISPOSE OF WASTE PROPERLY

- Improperly disposing of waste can threaten the environment and ecology. Potentially harmful waste used with HITACHI equipment includes such items as oil, fuel, coolant, brake fluid, filters, and batteries.
- Use leakproof containers when draining fluids. Do not use food or beverage containers that may mislead someone into drinking from them.
- Do not pour waste onto the ground, down a drain, or into any water source.
- Air conditioning refrigerants escaping into the air can damage the Earth's atmosphere. Government regulations may require a certified air conditioning service center to recover and recycle used air conditioning refrigerants.
- Inquire on the proper way to recycle or dispose of waste from your local environmental or recycling center, or from your authorized dealer.

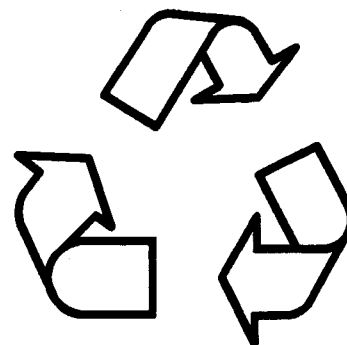

SA-226

516-E01A-0226-4

SAFETY SIGNS

All safety signs and their locations affixed on the machine are illustrated in the group. Make sure of the contents described in the safety signs through reading actual ones affixed on the machine to ensure safe machine operation. Always keep the safety signs clean. In case a safety sign is broken or lost, immediately, obtain a new replacement and affix it again in position on the machine. Use the part No. indicated under the right corner of each safety sign illustration when placing an order of it to the Hitachi dealer.

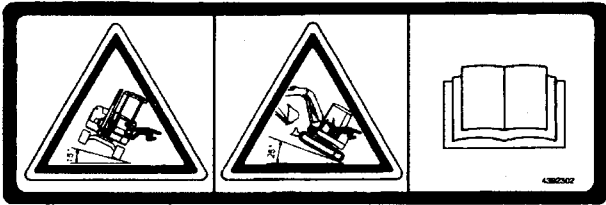

SS4392302

- When traveling on a slope, always move slowly. Do not travel across a slope, having an incline of more than 15 degrees, or up a slope of more than 25 degrees. Refer to the "SAFETY" and "OPERATING THE MACHINE" sections in the operator's manual for the details.

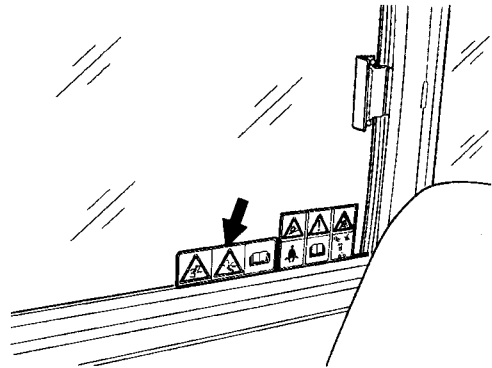

Cab

SS-2461

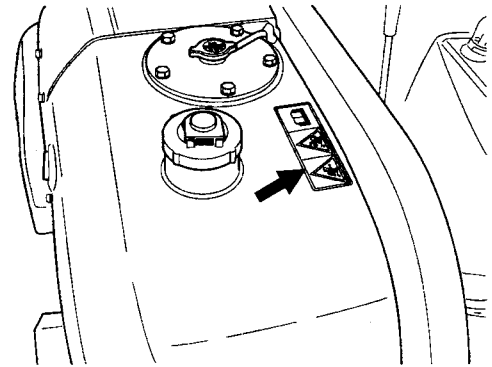

Canopy

SS-2462

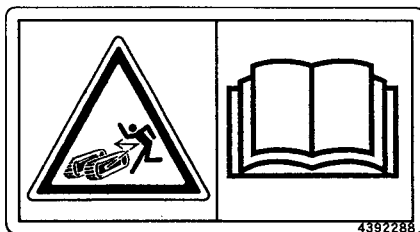

4392288

SS-1710

- Serious injury may result if the plug flies off the track adjuster. Read the Operator's Manual before loosening the track, and adjust the track sag following the correct procedure.

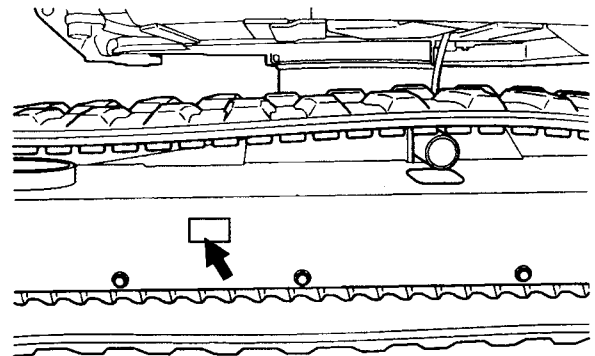

SS-2471

SAFETY SIGNS

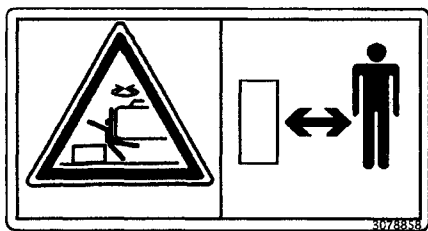

SS-1714

- Personnel in the swing radius may be crushed by the upperstructure when the machine swings. Stand clear of the swing radius.

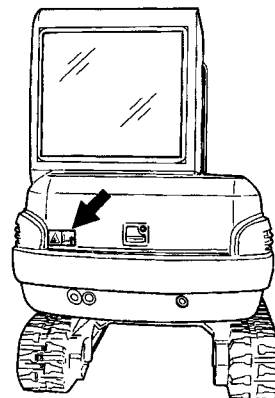

SS-2463

- Always read the Operator's Manual before operating, servicing, disassembling assembling and transporting the machine.

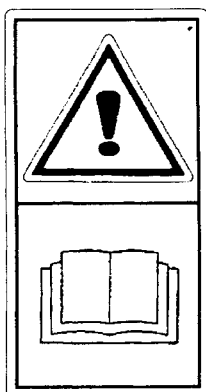

IMAGENO

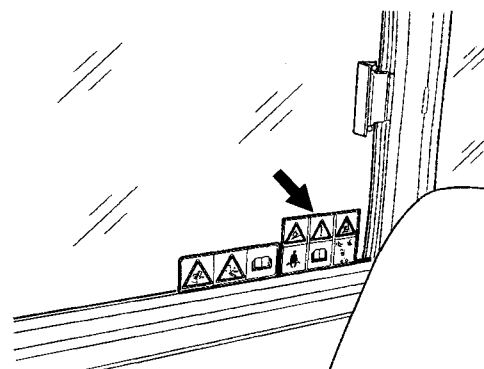

Cab

SS-2461

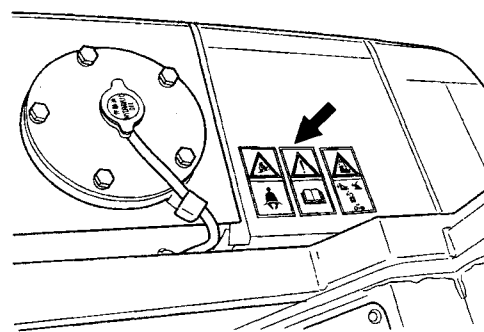

Canopy

SS-2462

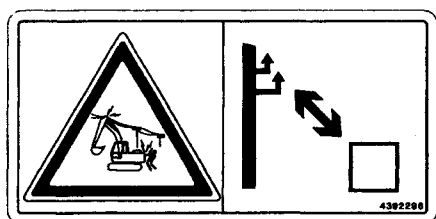

SS-1707

- Electrocutation is possible if the machine is operated too close to power lines. Always keep a safe distance from power lines.

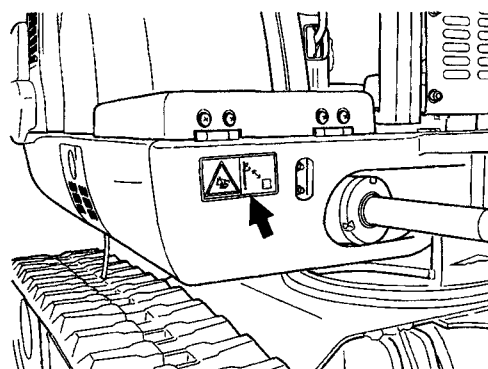

SS-2465

SAFETY SIGNS

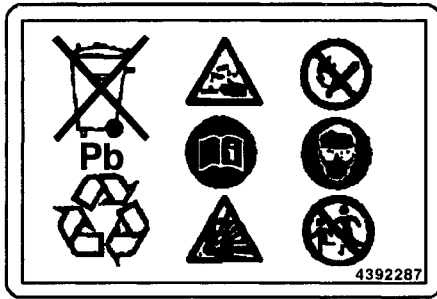

SS-1711

- Sing indicates explosion hazard that could cause injury. Never drill, cut with gas, hit and disassembly. Keep fire away as well.

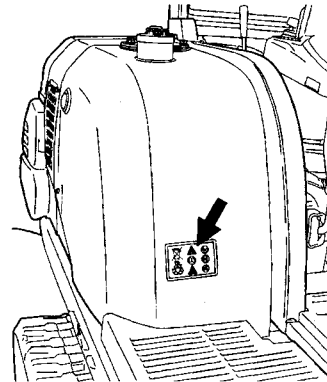

SS-2466

- Possible severe burns. Do not touch the engine components while they are hot.



SS4392289

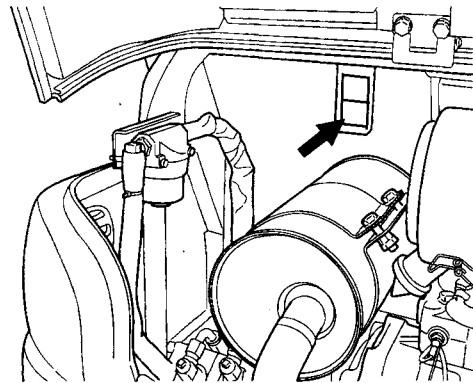

ZAXIS30, 35

M1LS-07-004

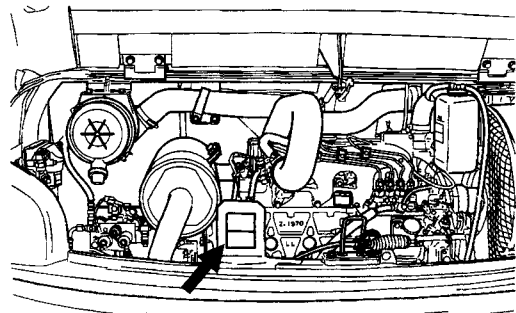

ZAXIS40, 50

M1LN-07-031

SAFETY SIGNS

- Hot coolant or oil may spout if the radiator or hydraulic oil cap is removed while the machine temperature is still high, possibly causing a burn. Wait until the machine has cooled to remove the cap.



SS-1703

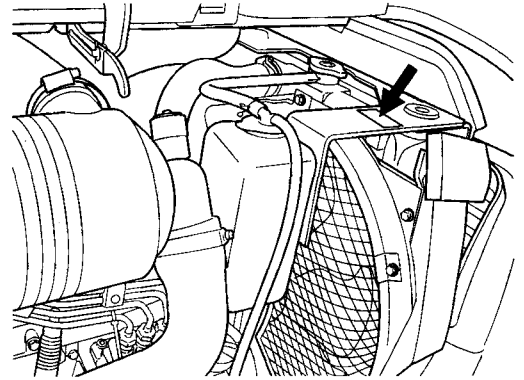

ZAXIS30, 35

M1LS-07-005

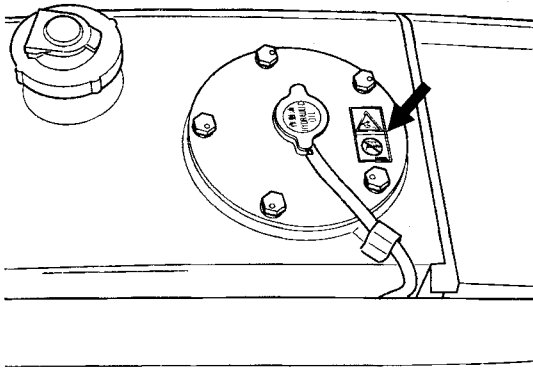

SS-2468

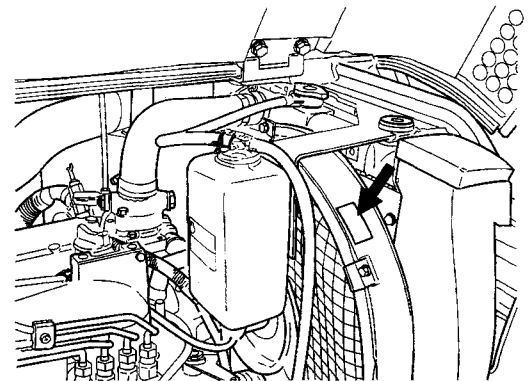

ZAXIS40, 50

M1LS-07-019

- Sign indicates the hazard of rotating parts, such as fan, etc. that could cause injury by being caught. Turn it off completely before inspection and maintenance.

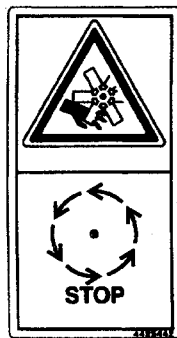

SS-1704

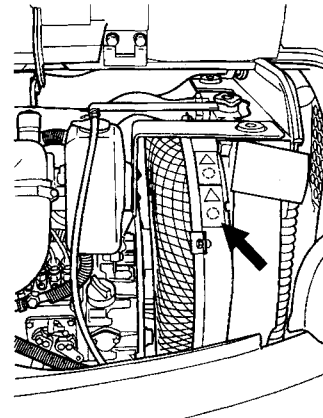

SS-2469

- Sign indicates the hazard of rotating parts, such as fan, etc. that could cause injury by being caught. Turn it off completely before inspection and maintenance.

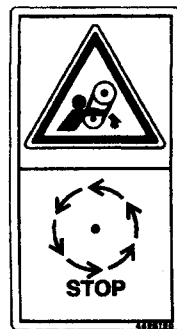

SS-1705

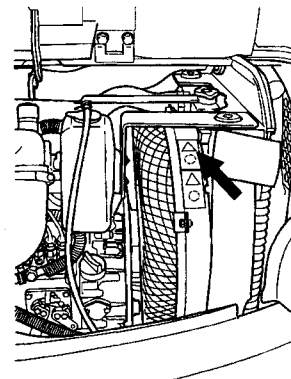

SS-2469

SAFETY SIGNS

- If the parked machine is unexpectedly moved, serious injury or death due to crushing may result. Be sure to lower the front attachment to the ground, lock the control levers, and remove the engine key before leaving the machine unattended.

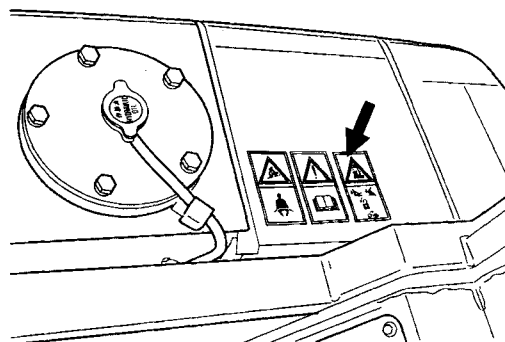
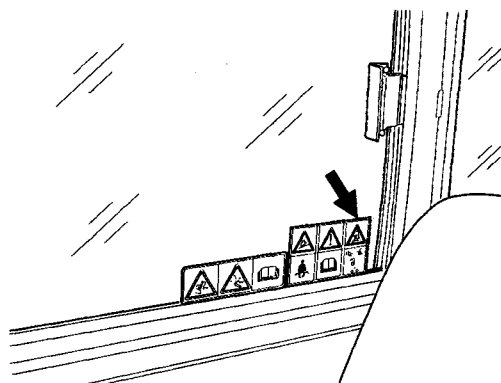
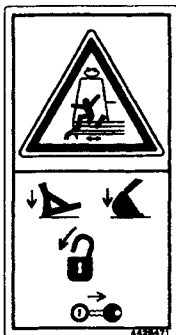

- Stand clear of the equipment. If knocked over by the equipment, serious injury may result.

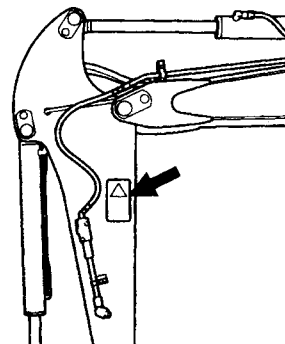
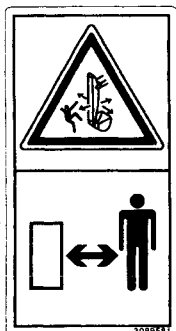

SAFETY SIGNS

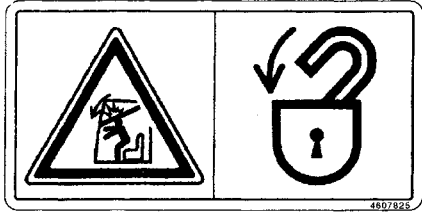

SS4607825

- Personal injury may result if the stored front window slips off. Always securely lock the window in the stored position (on the cab-equipped machine).

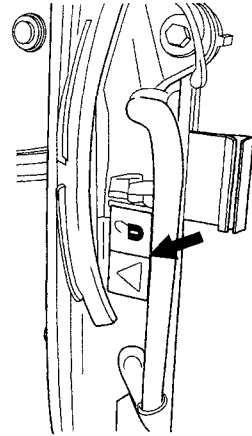

SS-2435

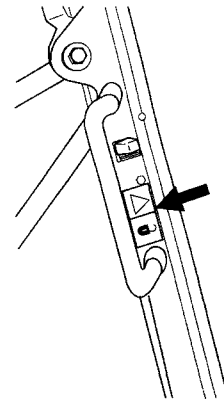

SS-2436

- Be sure to use the seat belt when operating the machine.



SS4448289

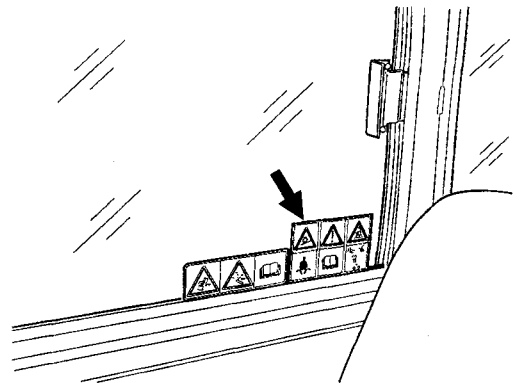

Cab

SS-2461

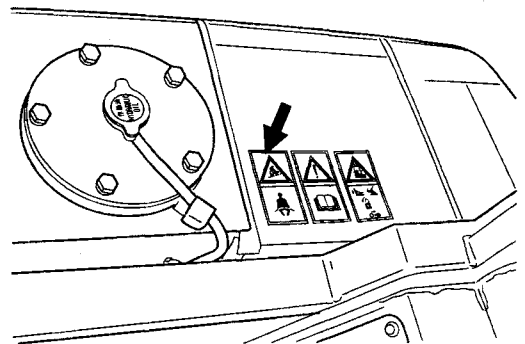

Canopy

SS-2464

SAFETY SIGNS

MEMO

Lined area for writing the memo.

COMPONENTS NAME

COMPONENTS NAME

1. Bucket
2. Arm
3. Bucket Cylinder
4. Arm Cylinder
5. Work Light
6. Boom Cylinder
7. Boom
8. Canopy(Cab)
9. Counterweight
10. Track Shoe
11. Travel Device
12. Track Frame
13. Boom Swing Cylinder
14. Blade Cylinder
15. Front Idler
16. Blade

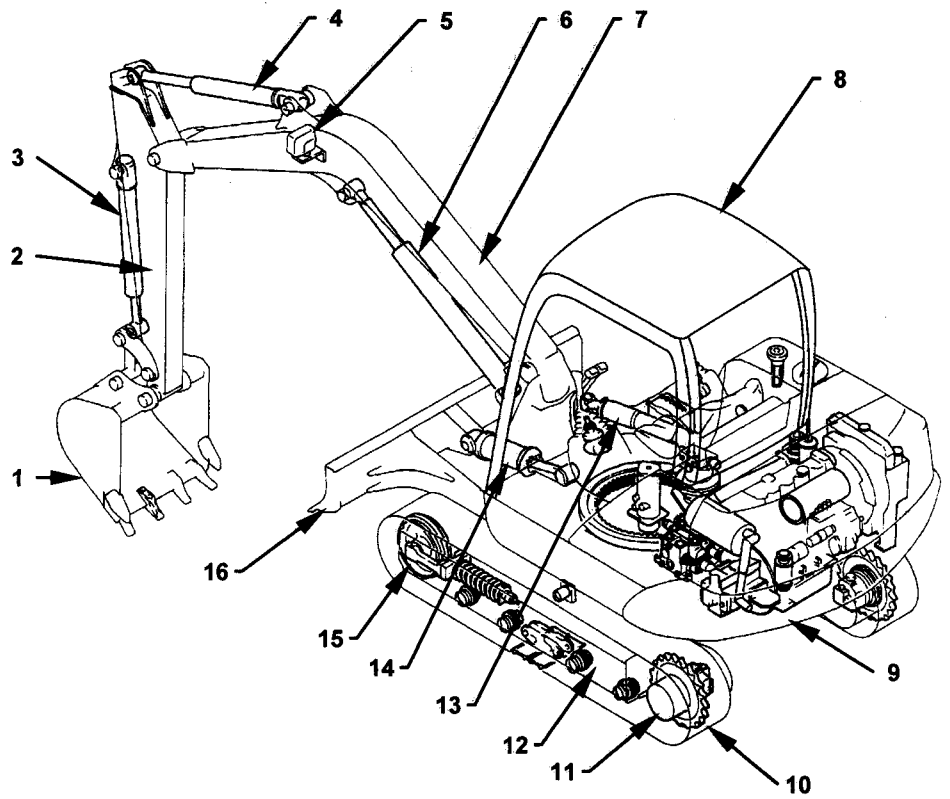

M1LS-01-001

OPERATOR'S STATION

PEDALS AND LEVERS

- 1- Left Control Lever/Horn Switch
(On Top of Lever)
- 2- Left Travel Lever
- 3- Right Travel Lever
- 4- Boom-Swing Pedal
- 5- Right Control Lever
- 6- Blade Lever
- 7- Engine Speed Control Lever
- 8- Key Switch
- 9- Operator's Seat
- 10- Switch Panel and Monitor Switch
- 11- Pilot Control Shut-Off Lever
- 12- Fast Speed Travel Pedal
- 13- Operator's Manual Box
- 14- Tool Box
- 15- Heater Control Switch
(Cab/canopy-equipped machines)
- 16- Wiper / Washer Switch
(Only on cab-equipped machines)

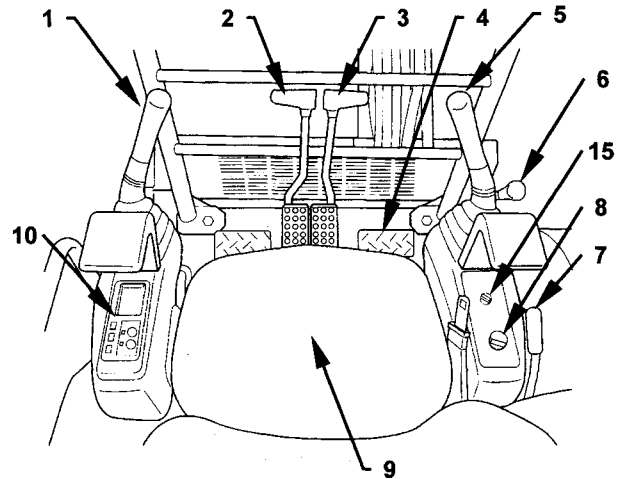

M1LS-01-002

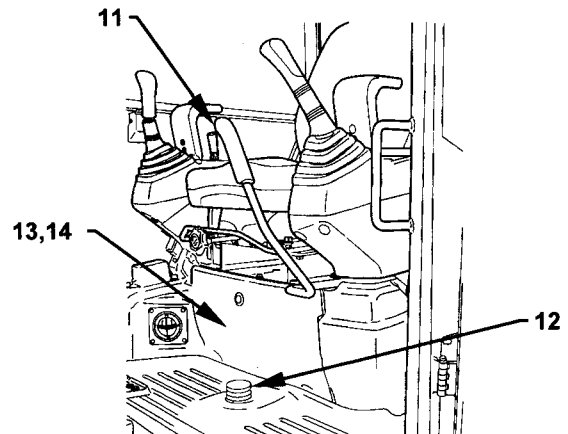

M1LS-01-003

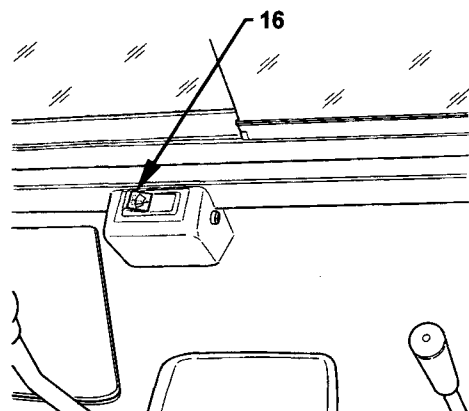

M1LS-01-004

OPERATOR'S STATION

MONITOR PANEL AND SWITCH PANEL

- 1- Switch Panel
- 2- Monitor Panel
- 3- Key Switch
- 4- Fuse Box
- 5- Electrical Socket

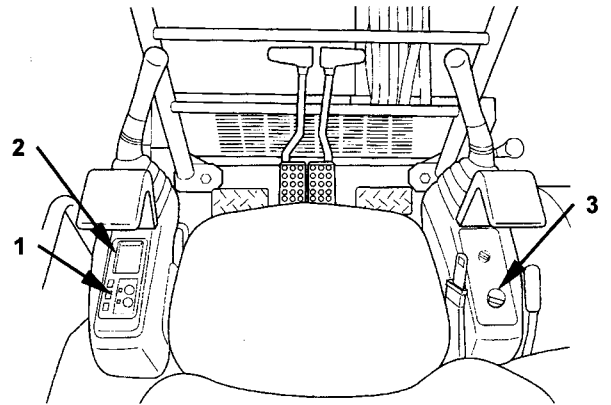

M1LS-01-002

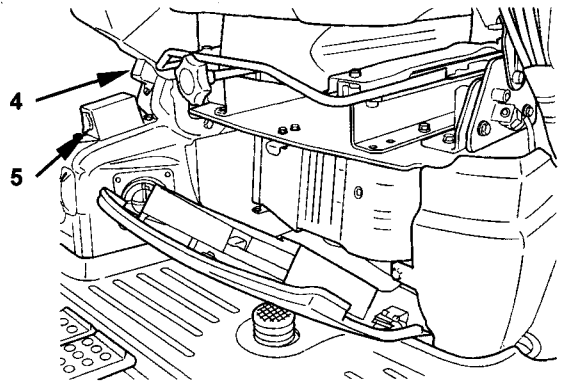

M1LS-01-005

OPERATOR'S STATION

KEY SWITCH

- 1- OFF (Engine Off)
- 2- ON (Engine On, Preheat)
- 3- START (Engine Start)

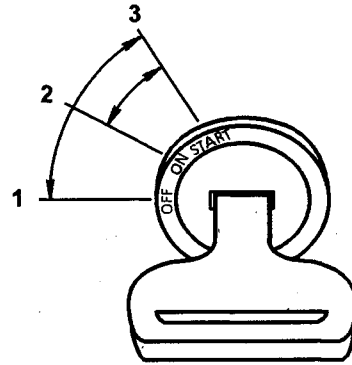

M586-01-012

WORK LIGHT SWITCH

Push work light switch (5) to turn on work lights (4), located on the boom, and at the top front of the operator's station.

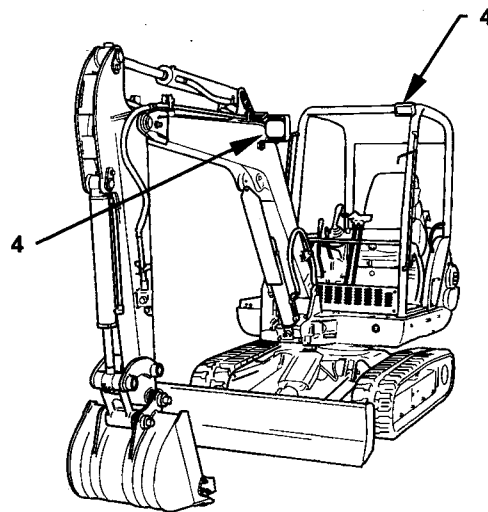

M1LS-01-006

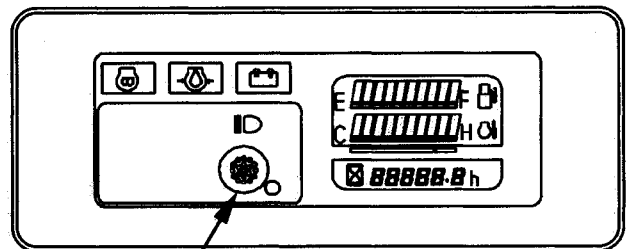

M586-01-014

OPERATOR'S STATION

MONITOR PANEL

- 1- Preheat Indicator
- 2- Engine Oil Pressure Indicator
- 3- Alternator Indicator
- 4- Fuel Gauge and Fuel Level Indicator
- 5- Coolant Temperature Gauge and Overheat Indicator
- 6- Hour Meter

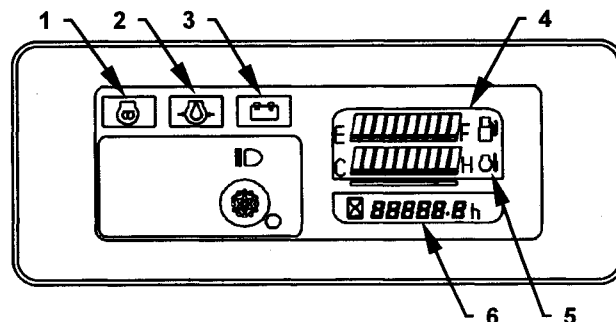

M586-01-014

ALTERNATOR INDICATOR

Red indicator will light with low alternator output.
Check electrical system.

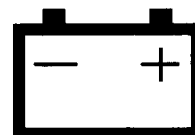

M424-01-004

ENGINE OIL PRESSURE INDICATOR

IMPORTANT: If engine oil pressure indicator comes on while operating, stop engine immediately.

Red indicator will light when engine oil pressure is low.
Stop engine immediately.

 **NOTE:** Cold oil, low oil level, or extreme off level operation may cause indicator to light.

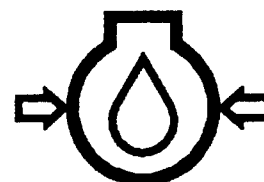

M481-01-007

OPERATOR'S STATION

PREHEAT INDICATOR

Yellow indicator will light when key switch is turned to ON position in cold weather. Light will turn off after a few seconds, indicating that the preheat is completed.



M424-01-009

COOLANT TEMPERATURE GAUGE AND OVERHEAT INDICATOR

COOLANT TEMPERATURE GAUGE

The engine coolant temperature is indicated. When the gauge segments remain in the white range, the coolant temperature is normal.

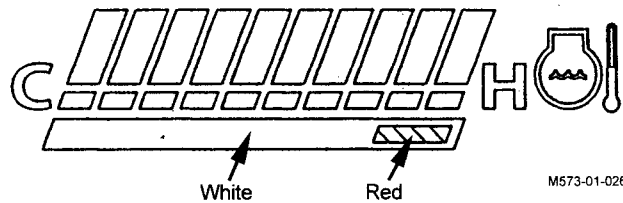

M573-01-026

OVERHEAT INDICATOR

If the coolant temperature rises extremely high, this indicator operates. When the gauge segments come ON in the red range, the segments start flashing and the buzzer sounds at the same time.

Immediately stop machine operation and reduce engine speed to the slow idle speed to lower the coolant temperature.



M573-01-029

OPERATOR'S STATION

FUEL GAUGE AND FUEL LEVEL INDICATOR

FUEL GAUGE

The fuel amount remaining in the fuel tank is indicated. E indicates that the fuel tank is empty. F indicates that the fuel tank is full. When the left most segment comes ON, the fuel tank is almost empty. Refill the fuel tank.



M573-01-027

FUEL LEVEL INDICATOR

When the fuel amount in the fuel tank is near empty, the warning signals operate. When only the first gauge segment comes ON, the buzzer sounds 5 times and the segment flashes at the same time.



M573-01-030

 **NOTE:** When the fuel level indicator flashes while the machine is operating on level ground, only 4 liters (ZAXIS30, 35), 7 liters (ZAXIS40, 50) of fuel remain in the fuel tank. Refill as soon as possible.

HOUR METER

This indicates the total operating hours of the machine. The right hand number indicate tenths (six minutes) of an hour.

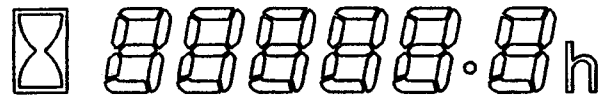

M573-01-028

OPERATOR'S STATION

CAB/CANOPY HEATER (Cab/canopy-equipped machine)

The cab heater is controlled in two modes by operating switch (1).

 **NOTE:** Be sure to close the shutoff valve on the engine side when the heater is not being used.

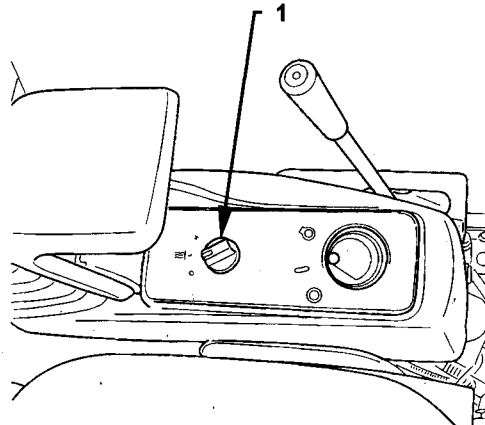

M1LS-01-007

WIPER/WASHER SWITCH (Only on cab-equipped machines)

IMPORTANT: Washer motor may be damaged if washer switch (2) is held for more than 20 seconds, or continually operated with no fluid in the washer.

Push wiper switch (2) to operate the wiper: When wiper switch (2) is pushed further, the washer fluid sprays. As long as wiper switch (2) is pushed, washer fluid continues to be sprayed.

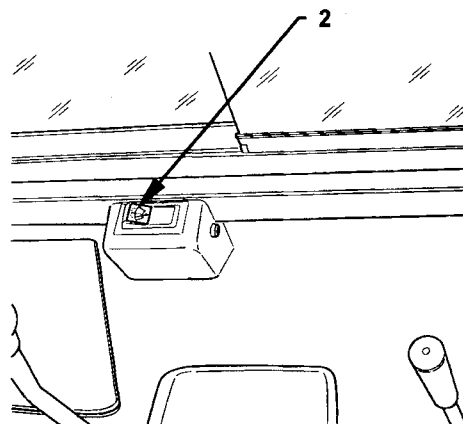

M1LS-01-004

OPERATOR'S STATION

OPENING AND CLOSING FRONT WINDOW (Only on cab-equipped machines)

⚠ CAUTION: Front window comes forcefully.
Close window only when sitting on
the operator's seat. Guide window
down slowly.

Opening:

1. Push in lock switches (1) to unlock Window.
2. Pull Window up and back until Slide lock switches (1) fall into boss holes and Lock.

Closing:

1. To close front Window, perform procedures shown in steps (1) to (2) in reverse. These are:
 - a. Push in Lock switches (1), to unlock Window
 - b. Pull Window down slowly
 - c. Be sure that the front window is locked

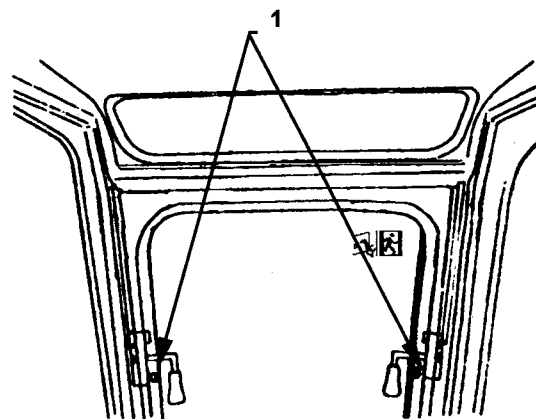

M1LN-01-007

OPERATOR'S STATION

EMERGENCY EXIT (Only on cab-equipped machines)

If the operator's cab door should not open in an emergency, escape in the following methods:

1. Open the front windows. Escape through the windows.

 **NOTE:** See page "OPENING UPPER FRONT WINDOWS" for the opening method of the front windows.

 **CAUTION:** Be sure to wear safety glasses before breaking the window glass.

2. If the front window is difficult to open, break the front window glass using emergency evacuation tool (1). Then, escape through the broken window.
3. If the front window is not available for escaping, break the rear window glass using emergency evacuation tool (1). Then, escape through the broken window.

 **NOTE:** The emergency exit decals are affixed to the front and rear windows.

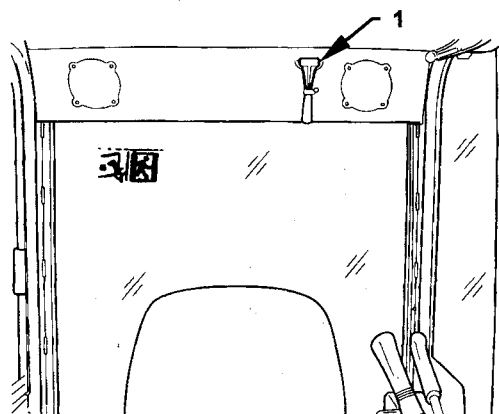

M1LS-01-008

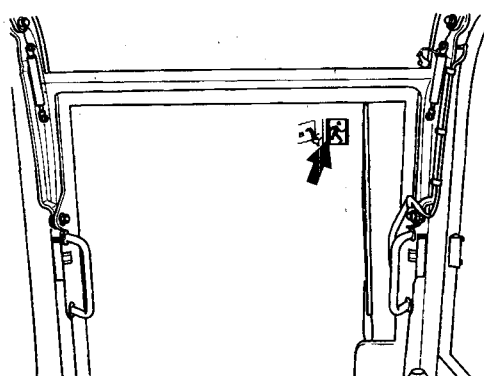

Front Window

SS-2470

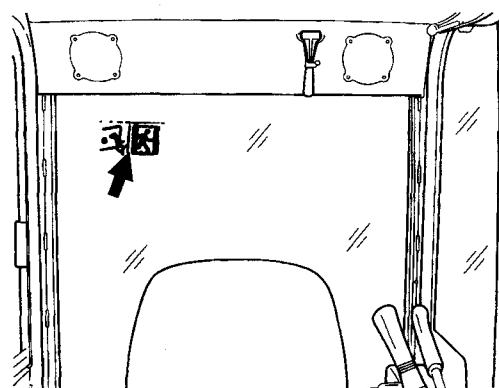

Rear Window

M1LS-01-008

OPERATOR'S STATION

TOOL BOX AND OPERATOR'S MANUAL BOX

Tool box (1) and an operator's manual box (2) are around the operator's seat.

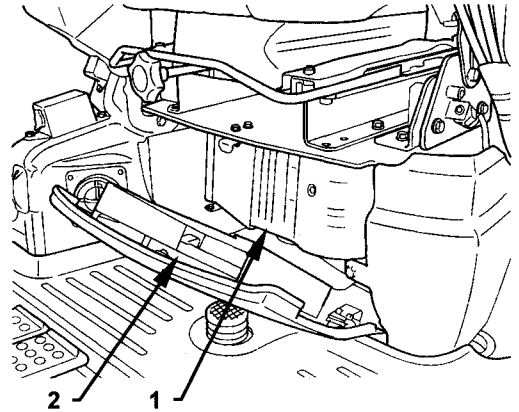

M1LS-01-005

CAB DOOR RELEASE BUTTON (Only on cab-equipped machines)

When opening the cabin door, lock it in the fully opened position. Open the door all the way, until it locks in the catch on the side of the cabin.
Pull button (3) to unlock the door.

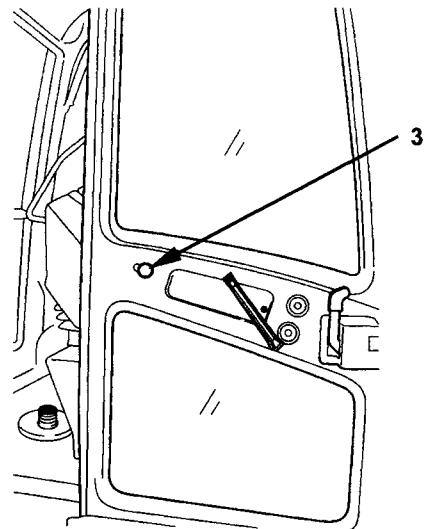

WM1LN-01-004

CAB LIGHT

Move switch (4) to turn the inside cab light on or off.

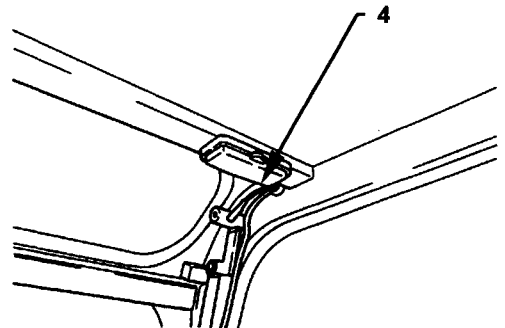

M585-01-021

OPERATOR'S STATION

ADJUSTING THE OPERATOR'S SEAT

1. Pull lever (1) to the upward the seat forward or rearward. Release the lever to lock.

 **NOTE:** *Seat slide has positioning stops every 10 mm. Length adjustment from full rearward to full forward is 120 mm.*

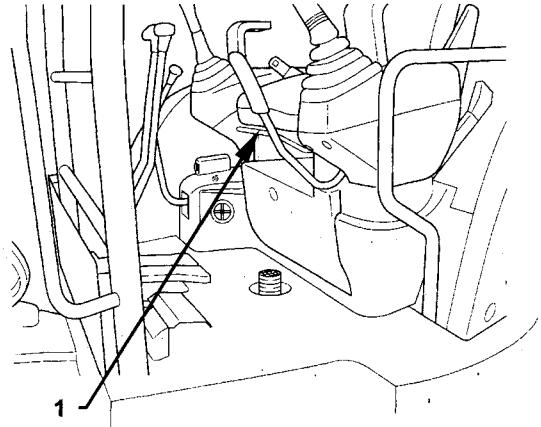

M1LA-01-009

OPERATOR'S STATION

SEAT BELT



CAUTION: Be sure to use the seat belt when operating the machine.

Before operating the machine, be sure to examine seat belt (1), buckle (2), or attaching hardware. Replace seat belt (1), buckle (2), or attaching hardware if they are damaged, or worn. Replace seat belt (1) every three years, regardless of appearance.

Seat Belt

1. Confirm that seat belt (1) is not twisted and securely insert the end of seat belt (1) into buckle (2). Lightly pull on the belt to confirm that the buckle latches securely.
2. Adjust Seat belt (1) so that the belt is snug but comfortable.
3. Push button (3) on buckle (2) to unfasten seat belt (1).

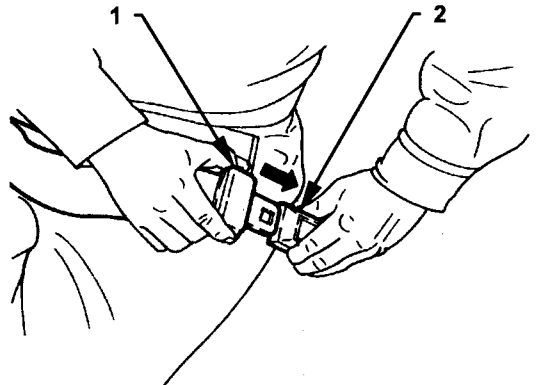

M573-01-014

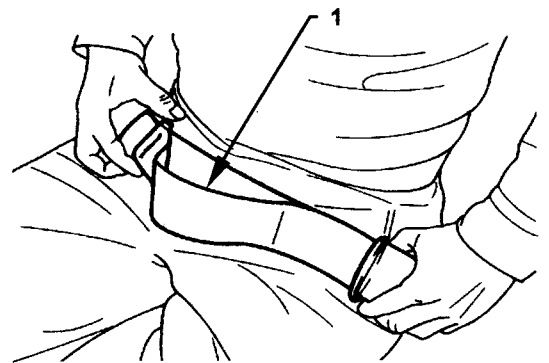

M107-01-045

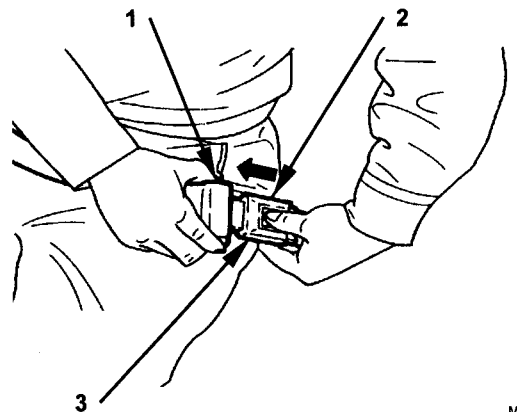

M573-01-015

OPERATOR'S STATION

MEMO

A series of horizontal dotted lines for writing a memo.

BREAK-IN

BREAKING IN A NEW MACHINE

Each machine is thoroughly inspected and adjusted at the factory. However, it is important to correctly break in your machine, following the table below:

HOURS	OPERATING
First 50 hours	Up to about 80% of full load
After the first 50 hours	Full load

Operating a new machine at full load without first breaking it in can cause scratches and/or seizures, consequently affecting the service life of the machine and its safe operation.

CORRECT BREAK-IN PROCEDURES

During the first 50 hours of operation:

1. Check the coolant level, engine oil level, and hydraulic oil level, and check for leaks every day.
2. Service lubrication points regularly.
3. Tighten all accessible hardware regularly.
4. Check indicators and gauges often during operation.
5. Take care to warm up the machine properly, and to operate the machine under 80% of full load.
6. Be sure that all sounds and operations of the machine are normal.

BREAK-IN

MEMO

A series of horizontal dotted lines for writing a memo.

OPERATING THE ENGINE

BEFORE STARTING ENGINE

1. Confirm that pilot control shut-off lever (1) is in the LOCK position.
2. Confirm that all control levers are placed in neutral.
3. Check indicator bulbs as follows:
Turn key switch to ON position. All indicator lights and warning lamps will come on. They will stay on for approximately 3 seconds, except for alternator (2) and engine oil pressure (3) indicator, which will continue to stay on further. If any lamp fails to light, the bulb may be burned out.

The lamps also stay on for approximately 3 seconds when the key switch is turned to START position.
4. Adjust the seat to allow full pedal and control levers stroke with the operator's back against the backrest. Fasten the seat belt.

-  **NOTE:**
- Use a wet cloth when wiping dust off monitor or switch panels to prevent damaging the panel face.
 - Rubber is used on the switch parts. Take care not to tear the rubber-made parts with sharp-edged tool, such as a screwdriver.

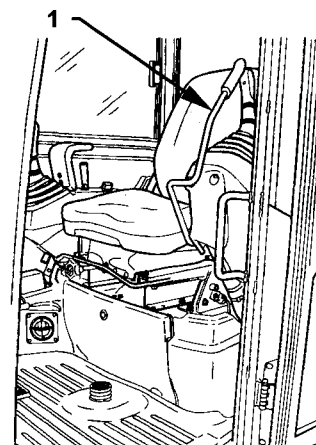

M1LS-03-001

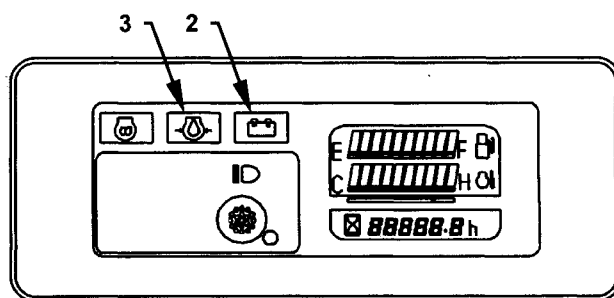

M586-01-014

ENGINE SPEED CONTROL LEVER

Use the engine speed control lever to adjust engine speed.

Move the lever backward (5) to increase speed.
Move the lever forward (4) to decrease speed.

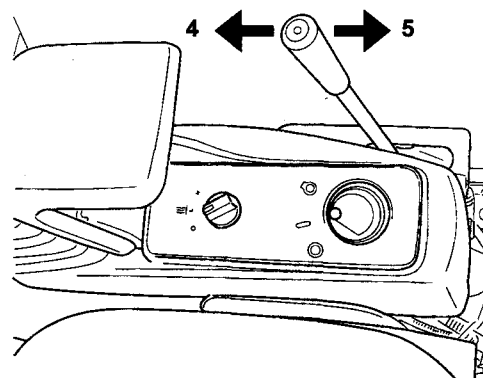

M1LS-01-007

OPERATING THE ENGINE

STARTING THE ENGINE

1. Turn the key switch to the ON position.
In cold weather, the preheat indicator will light.
2. Sound the horn to alert persons nearby.
If the horn does not sound, be sure to repair the trouble before operating the machine.
3. Pull the engine speed control lever back halfway.
4. After confirming that the preheat indicator goes off, turn the key switch to START position.

IMPORTANT: Never operate the starter motor for more than 10 seconds at a time.
If the engine fails to start, return the key switch to OFF. Wait for more than 30 seconds, then try again. Do not attempt to turn the key switch again until the engine comes to a complete stop, otherwise the starter may be damaged.

5. When the engine starts, release the key; the key switch will automatically return to the ON position.

NOTE: This machine is equipped with Auto Glow System. Sensing the coolant temperature, the duration of preheating is automatically set. Be sure to wait until the preheat indicator goes off with the key switch turned to the ON position, as specified above. When atmospheric temperature is cold, it is possible to operate the starter motor for within 15 seconds at a time.

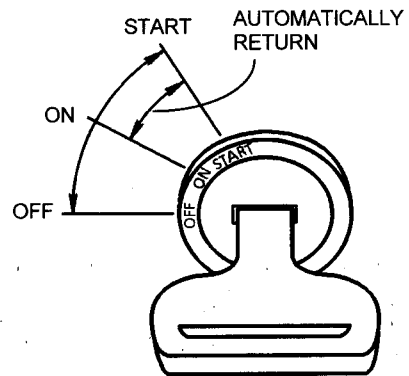

M588-01-012



M424-01-009

CHECK INSTRUMENTS AFTER STARTING

IMPORTANT: Prevent possible damage to engine. If indicator lights do not go out after starting engine, IMMEDIATELY STOP THE ENGINE and correct the cause.

Check that:

1. Coolant temperature gauge (1) is in the white zone.
2. Alternator indicator (2) is off.
3. Engine oil pressure indicator (3) is off.
4. Engine noise and exhaust gas are normal.

NOTE: Checking exhaust gas (with no load, after warming up)

colorless or faint blue	---	normal (complete combustion)
black	---	abnormal (incomplete combustion)
white	---	abnormal [burning oil (oil ring worn) or coolant leakage into cylinder]

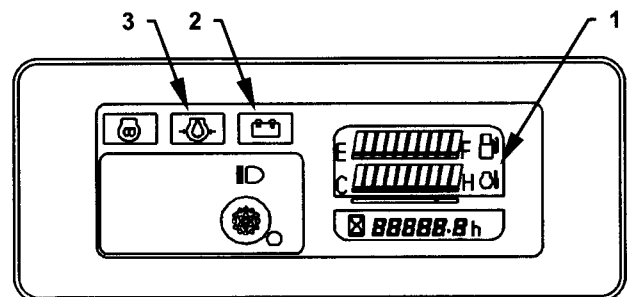

M588-01-014

OPERATING THE ENGINE

USING BOOSTER BATTERIES



CAUTION: An explosive gas is produced while batteries are in use or being charged. Keep flames or sparks away from the battery area. Do not continue to use or charge the battery when the electrolyte level is lower than specified. Explosion of the battery may result. Charge the batteries in a well ventilated area. Park the machine on a dry, firm or concrete surface, not on steel plates. If the machine is parked on steel plate, dangerous sparks may be unexpectedly created on the machine. Never connect a positive terminal to a negative terminal, as a dangerous short circuit will occur.

IMPORTANT: The machine electrical system is a 12 volt negative (-) ground. Use only 12 volt booster batteries.

When the machine batteries are exhausted, start the engine using booster batteries as shown below.

1. Connecting the booster batteries
 - a. Stop the engine of the machine on which booster batteries are mounted.
 - b. Connect one end of red cable (1) to the positive (+) terminal of the machine batteries, and the other end to the positive (+) terminal of the booster batteries.
 - c. Connect one end of black cable (2) to the negative (-) terminal of the booster batteries, and then make ground connection to machine frame of the machine to be started with the other end of black (-) cable (2).
 - d. Start the engine

2. Disconnecting the booster batteries
 - a. Disconnect black negative (-) cable (2) from machine frame first.
 - b. Disconnect the other end of black negative (-) cable (2) from the booster batteries.
 - c. Disconnect red positive (+) cable (1) from the booster batteries.
 - d. Disconnect red positive (+) cable (1) from the machine batteries.



SA-032

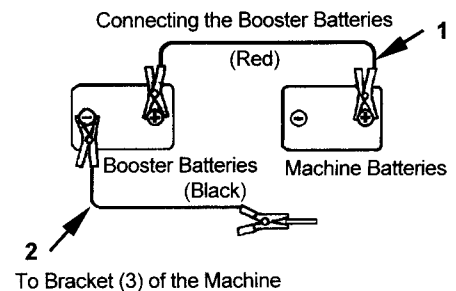

M503-03-002

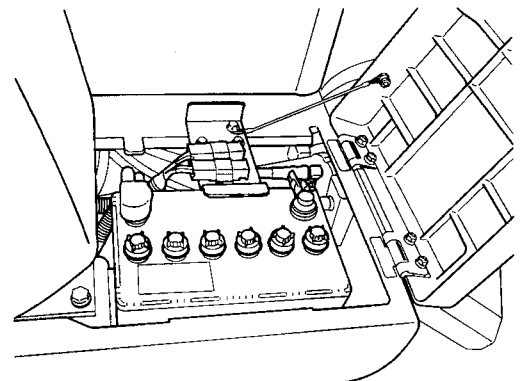

M1LS-03-002

OPERATING THE ENGINE

STOPPING THE ENGINE

1. Park the machine on a level surface.
2. Lower the bucket and blade to the ground.
3. Run engine at slow idle speed without load for 5 minutes.
4. Turn the key switch OFF to stop the engine.
5. Pull pilot control shut-off lever (1) up to lock all actuators in neutral.

IMPORTANT: In case the engine is difficult to stop by turning the key switch OFF, stop the engine by following the procedures below.

- Open the engine access cover.
- Move the red lever to the left
- After the engine is stopped, check and repair the cause of the trouble.

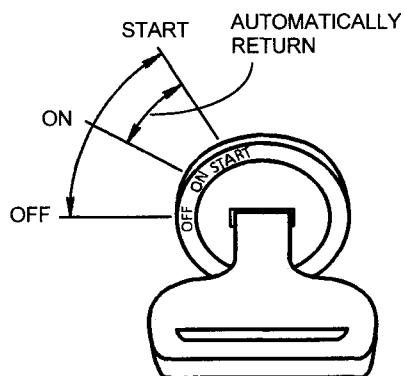

M588-01-012

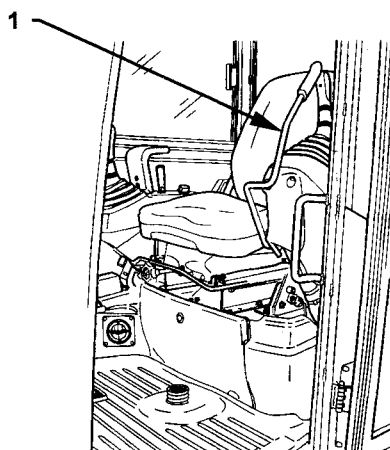

M1LS-03-001

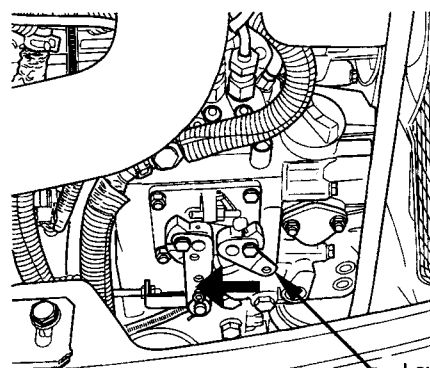

ZAXIS30, 35

Lever(Red)

M1LS-03-003

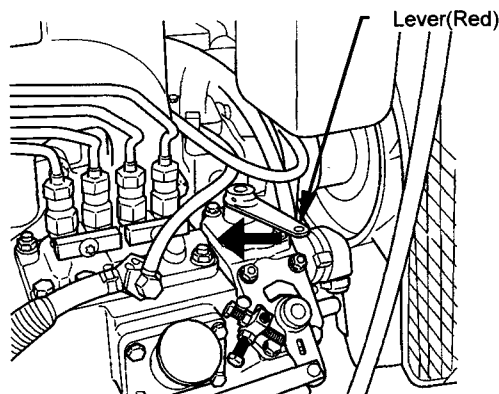

ZAXIS40, 50

Lever(Red)

M1LS-03-004

DRIVING THE MACHINE

TRAVEL LEVERS

CAUTION: In the standard traveling position, the blade is located in front of the operator's seat and the travel motors at the rear. If the travel motors are positioned at the front of the machine, the actions of the travel levers will be reversed. Be sure to confirm the position of the travel motors before traveling.

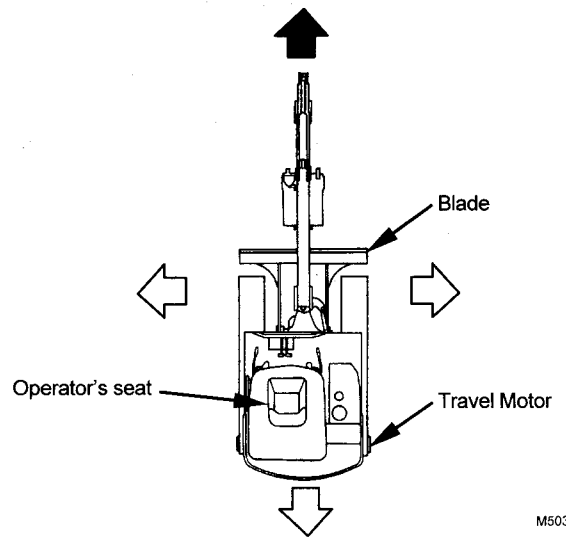

M503-01-002

1. Traveling in a Straight Line:

Move both levers forward together to travel forward.
Pull the levers back together to travel in reverse.

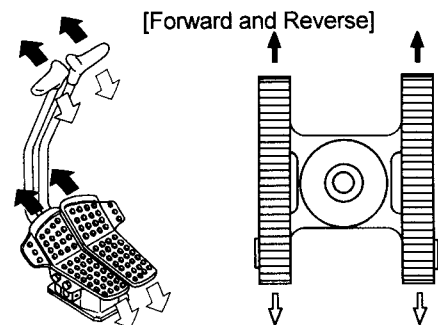

M104-04-003
M104-04-009

2. Pivot Turn:

Right Turn: Move left lever forward
Left Turn: Move right lever forward

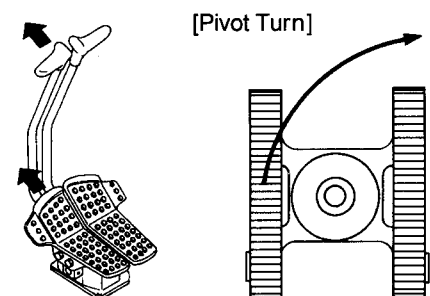

M104-04-005
M104-04-010

3. Spin Turn (short turn):

Move one lever forward and pull the other back.

NOTE: When travel levers are in neutral the travel brakes are applied automatically.

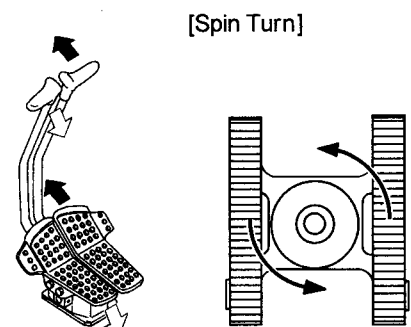

M104-04-007
M104-04-011

4. Traveling on Slopes:

- (1) Maximum grade: 47% (25 degrees)
- (2) When descending, operate the travel levers slowly and with extra caution.

NOTE: Neutral position: Travel brakes will stop or hold the machine.

DRIVING THE MACHINE

FAST SPEED TRAVEL PEDAL

CAUTION: Never attempt to shift the travel mode from the slow to fast while descending a slope. Otherwise, the machine may run away, possibly causing personal injury or death.

The machine travel speed is increased to the fast mode as long as fast speed travel pedal (1) is depressed. As soon as fast speed travel pedal (1) is released, the machine travels in the slow mode.

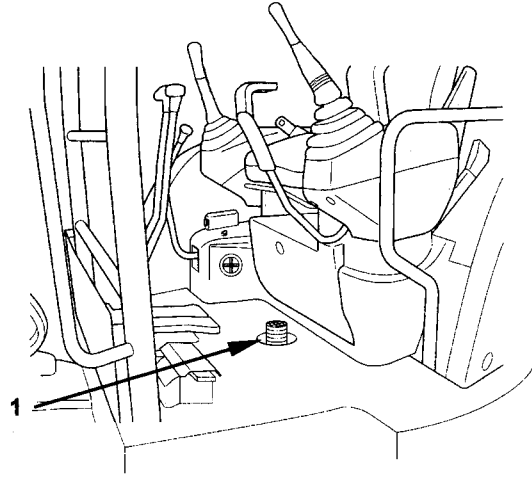

M1LA-01-009

DRIVING THE MACHINE

TRAVELING

CAUTION: Use a signal person when moving, swinging or operating the machine in congested areas. Coordinate hand signals before starting the machine.

- Determine which way to move travel levers for the direction you want to go before moving machine. When the travel motors are in the rear, pushing the levers forward moves the machine forward, towards the idlers.
- Select a travel route that is as flat as possible. Steer the machine as straight as possible, making small gradual changes in direction.
- Check the strengths of bridges and road shoulders before traveling on them, and reinforce if necessary.
- Use wood plates in order not to damage the road surface. Be careful of steering when operating on asphalt roads in summer.
- Use wood plates in order not to damage them when crossing train tracks.
- Do not make contact with electric wires or bridges.
- Measure the depth of the river using the bucket, and cross slowly when crossing a river. Do not cross the river when the depth of the river is deeper than the upper track shoe surface.
- Reduce engine speed when traveling on rough terrain. Select slow travel speed. Slower speed will reduce possible damage to the machine.
- Avoid operations that may damage the track and undercarriage components.
- Always clean snow and ice from track shoes before loading and unloading machine, to prevent the machine from slipping during freezing weather.

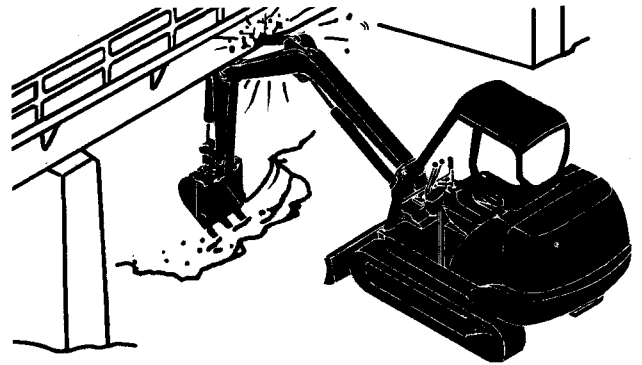

SA-673

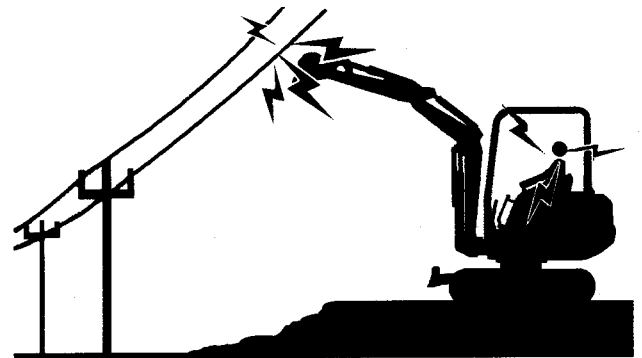

SA-674



M586-05-002

DRIVING THE MACHINE

OPERATING ON SOFT GROUND

CAUTION: Keep the angle between boom and arm 90° to 110° and position the bucket's round side on the ground.

Avoid traveling on very soft ground that does not have sufficient strength to firmly support the machine.

If the machine is operated on very soft ground or becomes stuck, it may be necessary to clean the track frame area.

Swing the upperstructure 90° and lower the bucket to raise one track off the ground. Make sure to keep the angle between the boom and arm 90° to 110° and position the bucket's round side on the ground.

Rotate the raised track back and forth to remove mud and dirt.

After lowering the track to the ground, slow travel speed. Carefully move the machine to firm ground.

Tow the machine if it becomes stuck but can still operate its engine. Be sure to attach a towing wire correctly.

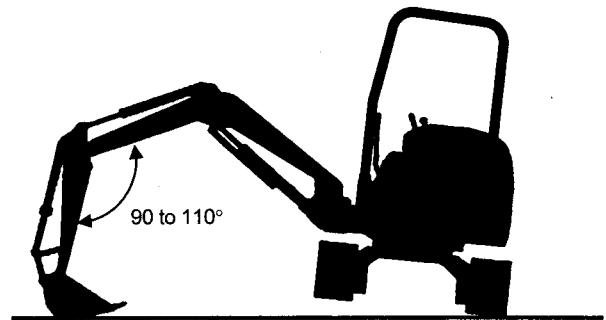

M586-05-003

RAISE ONE TRACK USING BOOM AND ARM

CAUTION: Keep the angle between boom and arm 90° to 110° and position the bucket's round side on the ground.

Swing the upperstructure 90° and lower the bucket to raise track off ground. Do not dig bucket teeth into the ground when using the hoe bucket reversed.

If a maintenance procedure must be performed under the machine, place blocks under machine frame to support the machine.

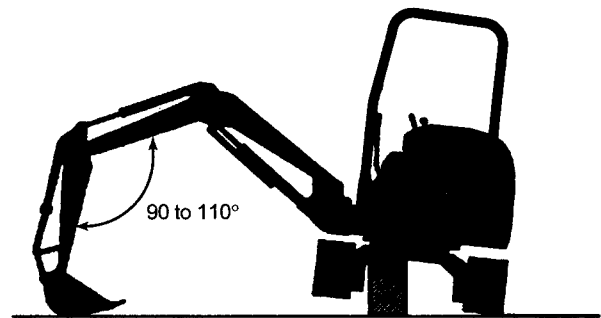

M586-05-004

DRIVING THE MACHINE

TOWING MACHINE A SHORT DISTANCE

⚠ CAUTION: Cables, straps, or wire ropes can break causing serious injury. Do not tow machine with damaged chains, slings, straps, wire ropes or frayed cables. Always wear gloves when handling cable, straps or wire ropes.

When your machine becomes stuck but the engine is still operational, attach wire rope tow lines as illustrated at right, and slowly tow your machine to firm ground using another machine.

Be sure to attach the wire ropes around the track frames of both machines as illustrated.

To prevent the wire ropes from being damaged, place some protective material between the track frame and the wire ropes.

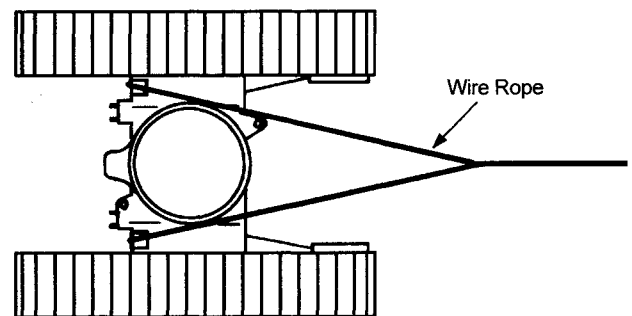

M503-05-025

DRIVING THE MACHINE

OPERATING IN WATER OR MUD

IMPORTANT: Avoid submerging the swing bearing, swing gears and center joint in water or mud. If these parts are submerged in water or mud, be sure to clean them and reapply grease as soon as possible, else damage may occur. Also consult your authorized dealer for instructions.

1. If the footing is even and the water slow running, the machine can operate in water up to the upper track shoe surface (A).
2. When operating in such conditions, check the machine's position often. Reposition the machine if necessary.

	A
ZAXIS30, 35	470 mm (18.5 in)
ZAXIS40, 50	535 mm (21.1 in)

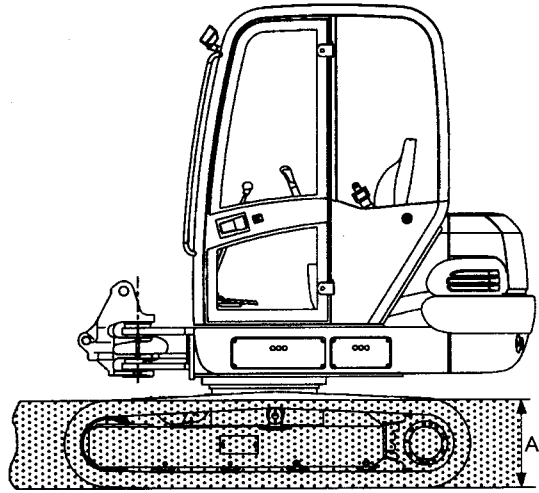

M1LS-05-005

DRIVING THE MACHINE

PRECAUTIONS FOR TRAVELING ON SLOPES

⚠ CAUTION: Avoid possible injury from traveling on slopes. Tipping over or skidding down of the machine may result. Thoroughly read and understand precautions below and be sure to travel at slow speed on slopes. Never attempt to travel on slopes with the bucket loaded or any load suspended by the bucket.

1. Never attempt to ascend or descend 25 degrees or steeper slopes. Use these gradient values as an operation guide. They may be reduced if soil condition changes.
2. Be sure to fasten the seat belt.
3. Keep the bucket pointed in the direction of travel, approximately 200 to 300 mm (8 to 12 in) (A) above the ground.
4. Traveling across the face of slope or steering on a slope may cause the machine to skid or turnover. If the direction must be changed, move the machine to level ground, then, change the direction to ensure safe operation.
5. Avoid swinging the upperstructure on slopes. Never attempt to swing the upperstructure and boom downhill. The machine may tip over. If swinging uphill is unavoidable, carefully operate the upperstructure and boom at slow speed.
6. If the engine stalls on a slope, block both tracks with stopper. Return the control levers to neutral. Then, restart the engine.
7. Be sure to thoroughly warm up the machine before ascending steep slopes. If hydraulic oil has not warmed up sufficiently, sufficient driving power to ascend may not be obtained.

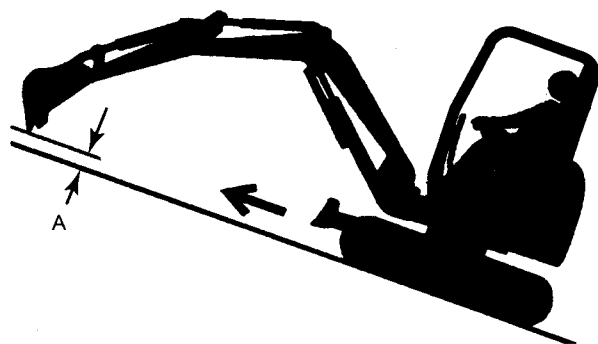

M586-05-006

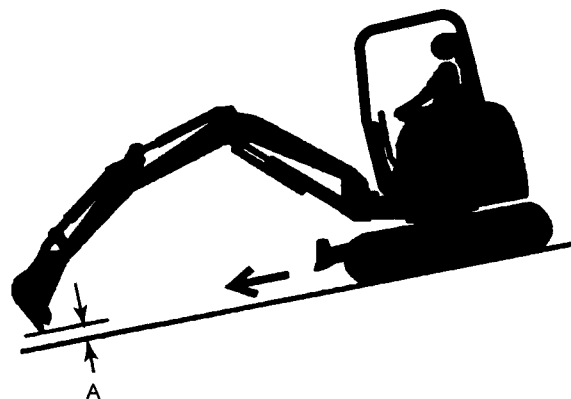

M586-05-007

DRIVING THE MACHINE

PARKING AND STOPPING ON A SLOPE

⚠ CAUTION: Parking and stopping on a slope is extremely dangerous. If parking or stopping on a slope is unavoidable, follow these precautions.

- If the engine stalls on a slope, block both tracks with stopper. Place all levers in the neutral position, and then restart the engine.
- When stopping on a slope even for a short time, be sure to lower both the bucket and the blade to the ground and to place all levers in the neutral position. Also, put blocks at the downhill end of the tracks.
- Before attempting to travel up a slope, be sure that the engine and hydraulic oil are properly warmed up. Otherwise the sluggish motion of the machine on a steep hill could lead to trouble.

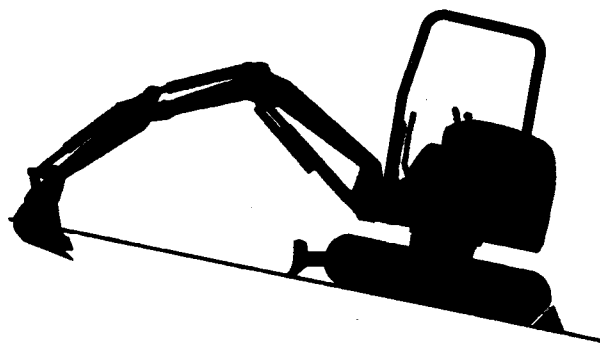

M586-05-008

PARKING THE MACHINE

1. Park the machine on a level, solid surface. Position the arm vertically and lower the bucket and blade to the ground.
2. Run the engine at slow idle speed without load for 5 minutes.
3. Turn the key switch to OFF to stop the engine. Remove the key from the switch.
4. Pull pilot control shut-off lever (1) into the fully LOCK position.
5. Close the window and cab door, if a cab is provided. Be sure to lock the cab door with a key.

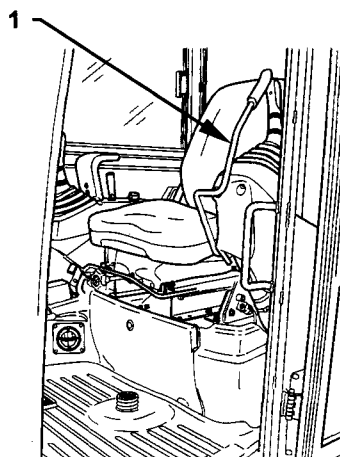

LOCK Position

M1LS-03-001

OPERATING THE MACHINE

CONTROL LEVER (ISO EXCAVATOR PATTERN)

⚠ CAUTION: Make sure you know the location and function of each control lever before operating. The upperstructure and/or front attachment may unexpectedly move in an attempt to look back because a part of operator's body may come into contact with the control lever(s). Take care not to come into contact with the control levers when looking back.

Labels showing the ISO EXCAVATOR pattern are provided in front of operator's right.

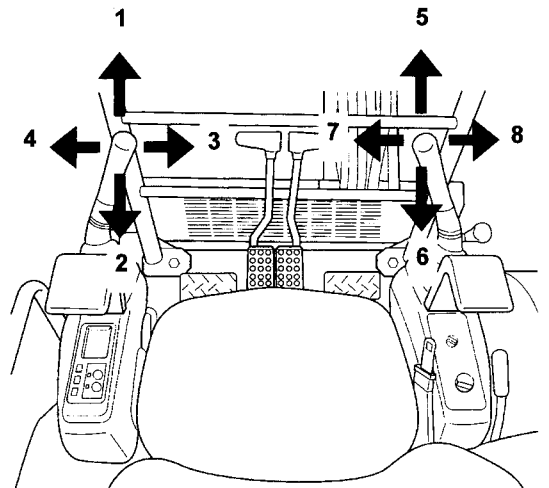

M1LS-01-002

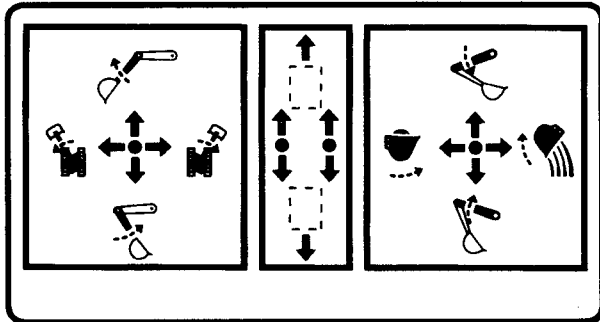

M588-05-050

When a lever is released, it automatically returns to neutral, stopping the function.

- 1- Arm Roll-Out
- 2- Arm Roll-In
- 3- Swing Right
- 4- Swing Left

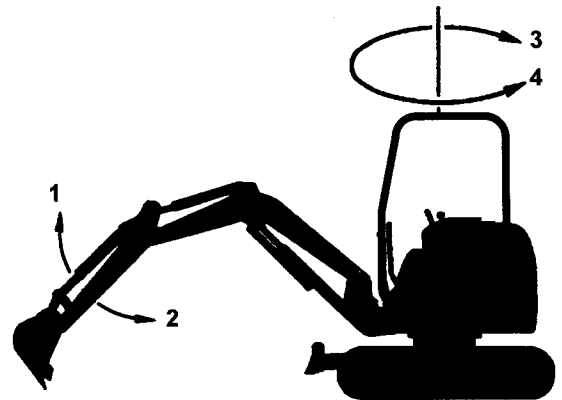

M586-05-032

- 5- Boom Lower
- 6- Boom Raise
- 7- Bucket Roll-In
- 8- Bucket Roll-Out

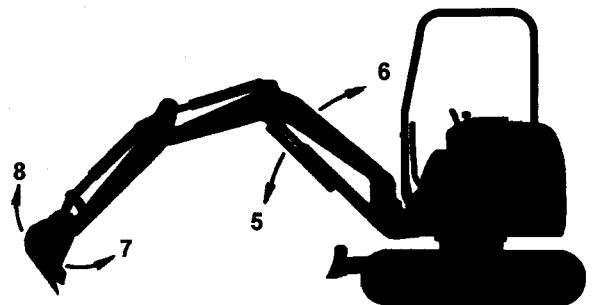

M586-05-033

OPERATING THE MACHINE

BOOM-SWING PEDAL

Boom-swing pedal (1) is located at the operator's right foot. Use this pedal to control the boom-swing function.

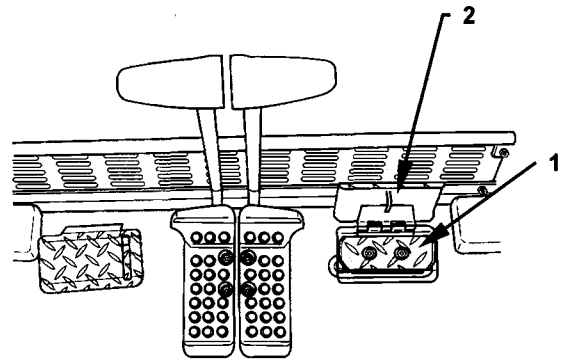

Unlocked

M1LS-05-003

Boom-Swing Operation

1. Turn cover (2) forward to unlock boom-swing pedal (1).
2. Push down on the left side of the pedal to swing left.
3. Push down on the right side of the pedal to swing right.
4. Turn cover (2) backward to lock boom-swing pedal (1) when boom-swing operation is no longer required.

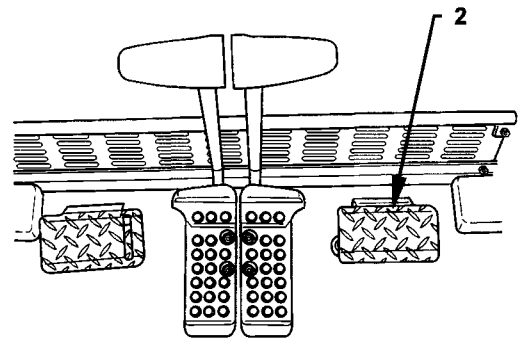

Locked

M1LS-05-004

- 1- Boom-Swing Pedal
- 2- Cover
- 3- Swing Left
- 4- Swing Right

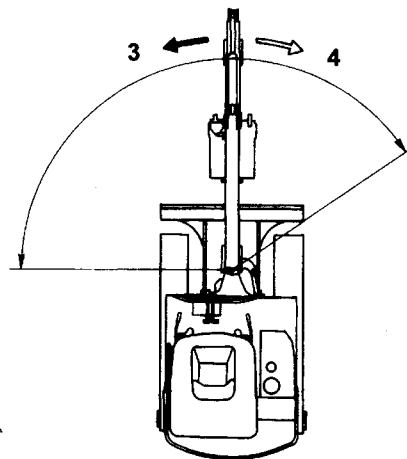

M503-01-010

OPERATING THE MACHINE

OPTIONAL PEDAL (P.T.O.-VALVE)

Optional pedal operation in the operator's station, (for use of hydraulic Breaker, Crusher, Tilt bucket, etc.)

Activating Procedure for Optional Pedal

To operate with optional equipment such as crusher, tilt bucket or hydraulic breaker, we have to change the flow of the hydraulic oil to arrange a correct flow to use the optional equipment.

Changing the hydraulic oil flow must be done with the P.T.O.-Valve, which is positioned on the right side of the machine. (See illustration).

- Place a wrench-bar into the hole on the hexagon bolt of the P.T.O.-Valve.
- Place the bolt in the correct position "position of the optional equipment", as shown.

Operation

1. Turn cover (1) forward to unlock optional pedal (2).
2. Step on the right or the left side of optional pedal (2), to operate the front-end attachment located on the top of the arm.

 **NOTE:** When not using pedal (2), turn cover (1) backward to lock optional pedal (2).

Operation (for use of hand breaker)

1. When use the hand breaker, hold optional pedal (2) in operating condition by cover (1).
2. Turn cover (1) forward to unlock optional pedal (2) and return it to neutral position, when optional pedal (2) is no longer required.

De-activating Procedure for Optional Pedal

Place the bolt of the P.T.O.-Valve in the correct position "position of the bucket", as shown.

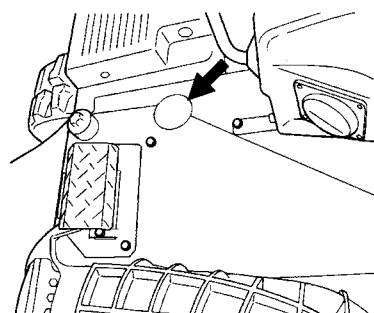

ZAXIS30, 35

M1LS-05-001

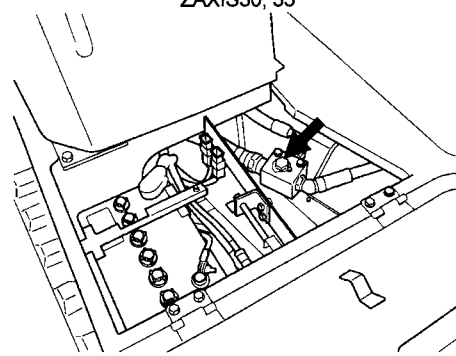

ZAXIS40, 50

M1LS-05-002

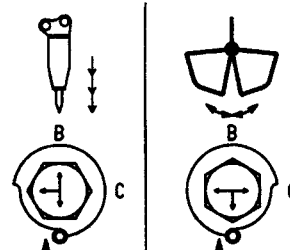

M1LN-05-009

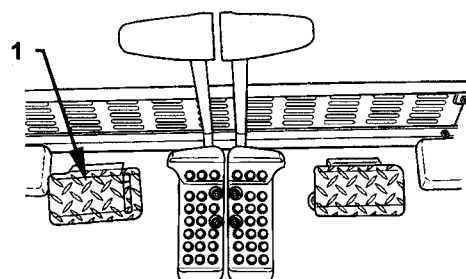

M1LS-05-004

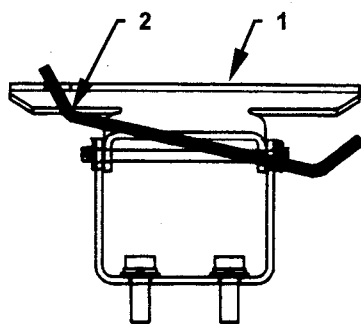

Locked

M1LS-05-005

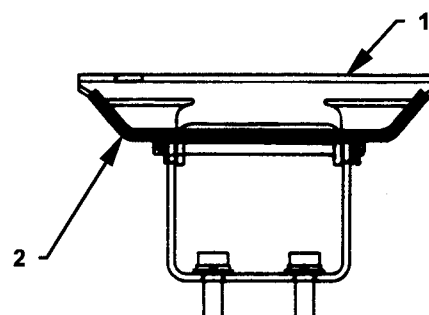

Unlocked

M1LS-05-006

OPERATING THE MACHINE

BLADE LEVER

Use blade lever (1) on the operator's right to raise and lower the blade.

When the lever is released, it automatically returns to neutral, keeping the blade in its position until the lever is operated again.

- 1- Blade Lever
- 2- Blade Raise
- 3- Blade Lower

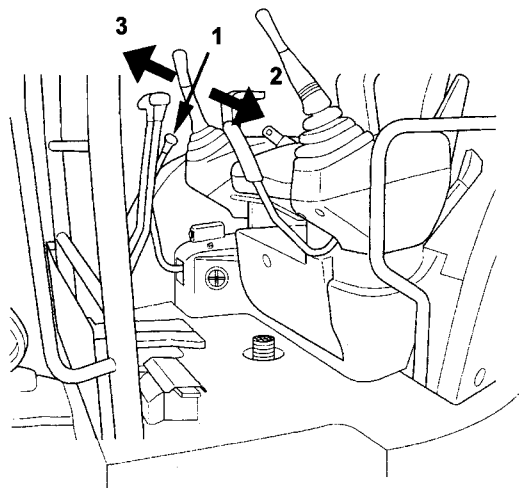

M1LA-01-009

Precautions for Blade Operation

This blade is designed as a light service attachment of the hydraulic excavator. Please keep the following points in mind:

- 1. This blade is designed to be used for dozing work only. Do not attempt to dig deeply with the blade. Doing so will damage not only the blade but the undercarriage as well.
- 2. Do not apply intensive or uneven loads to the blade. Never apply high-speed impact shock to the blade by running the machine into a load.
- 3. When jacking up the machine with this blade, the surface beneath the blade comes under high pressure, increasing the risk of surface collapse. Always be sure that the surface is strong enough to support the weight of the machine during operation. Avoid dangerous uneven distribution of weight to the blade by maintaining even contact between the blade and the ground.
- 4. While digging, take care not to allow the bucket to come into contact with the blade.

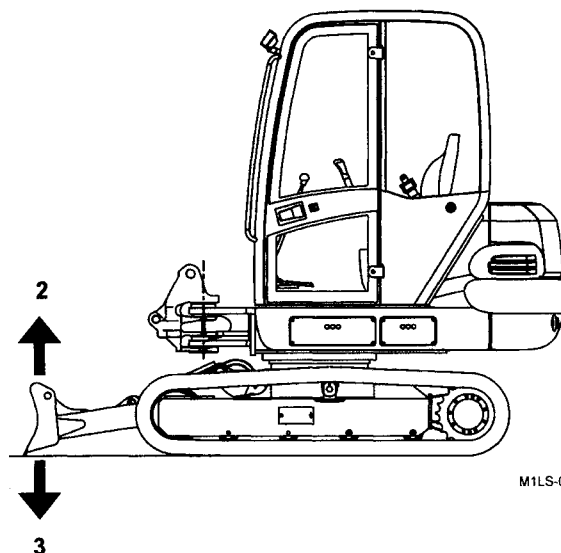

M1LS-05-001

OPERATING THE MACHINE

PILOT CONTROL SHUT-OFF LEVER

The pilot control shut-off lever is a device to prevent the machine from being unexpectedly operated if the control levers are accidentally moved when the operator is getting in or out of the operator's station.

Take care not to come into contact with these controls when getting in and out of the operator's station.

Pilot control shut-off lever (1) is linked to the console (2) latch mechanism so that the console (2) is raised in the LOCK position to aid in getting in and out of the operator's station and maintenance.



CAUTION:

- To deactivate control lever (3) function, be sure to pull pilot control shut-off lever (1) and raise console (2) to the fully locked position. To reactivate control lever (3) function, always hold and push pilot control shut-off lever (1) down. Never attempt to lower raised console (2) or control levers (3) to reactivate control lever (3) function without holding pilot control shut-off lever (1). Failure to do so will damage to console (2) and/or control levers (3).
- Always stop the engine and pull pilot control shut-off lever (1) to the full LOCK position before leaving the operator's station, even when leaving temporarily.
- Be sure to pull pilot control shut-off lever (1) to the full LOCK position before leaving the machine after each shift.



LOCK Position

M1LS-03-001

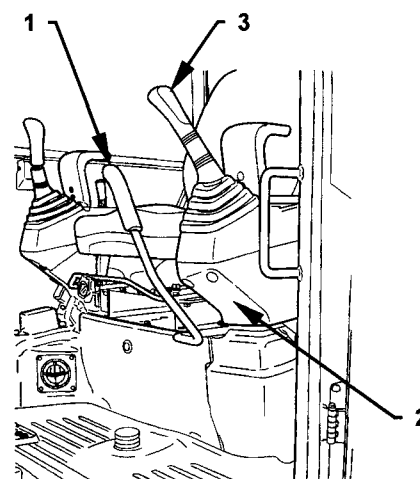

UNLOCK Position

M1LS-01-003

Pilot Control Shut-off Lever Operation

1. Before Leaving the Machine:
 - (1) Park the machine on a firm, level surface. Lower the bucket and blade to the ground. Return all control levers to neutral. Stop the engine.
 - (2) To deactivate control lever (3) function, be sure to pull pilot control shut-off lever (1) and raise console (2) to the fully locked position.

OPERATING THE MACHINE

2. Before Starting Operation:

CAUTION: Never attempt to lower raised console (to reactivate the pilot control shut-off function) by holding and pushing down control lever (3) and/or console (2). Always lower the console using pilot control shut-off lever (1).

Be sure to keep pilot control shut-off lever (1) in LOCK (raised) position when starting the engine. Slowly lower pilot control shut-off lever (1) to UNLOCK position before starting operation.

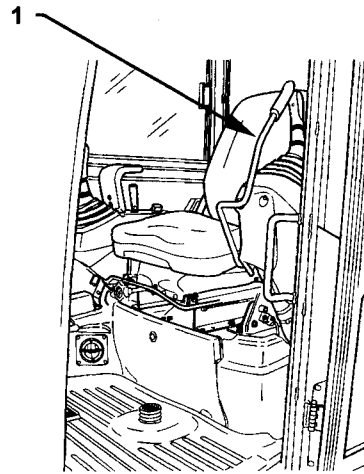

LOCK Position

M1LS-03-001

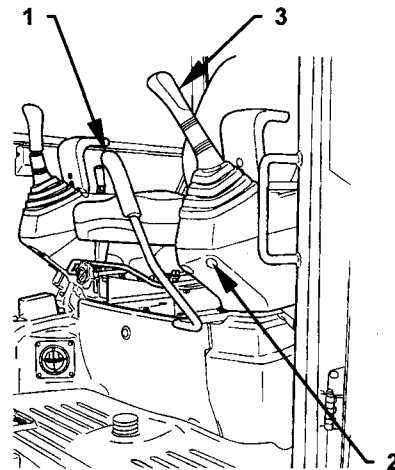

UNLOCK Position

M1LS-01-003

OPERATING THE MACHINE

WARMING UP OPERATION

The normal operating temperature of hydraulic oil is from 50 to 80°C (122 to 176°F). Hydraulic components may be seriously damaged if the machine is operated with hydraulic oil temperature below 20°C (68°F).

Before starting work, be sure to follow these warm-up procedures until the temperature of the hydraulic oil reaches above 20°C (68°F).

Warm-Up Procedures:

1. Run the engine at 100 to 200 min⁻¹ (rpm) above slow idle speed for 5 minutes.
2. With the engine speed control lever at the medium position, run the engine for 5 to 10 minutes.
3. Extend and retract each cylinder several times and lightly operate the swing and travel motors to warm up them.

WARMING UP IN COLD WEATHER

IMPORTANT:

- In cold weather, be sure to thoroughly warm-up the motors and cylinders.
- If the hydraulic circuit is continuously relieved for a certain amount of time, the temperature in the control valve would rise excessively. Never operate to stroke end more than 30 seconds. After relieving any function, up to 30 seconds, be sure to have a 5-10 second intermission.

1. Run the engine at medium speed for 5 minutes (longer if the air temperature is extremely low).
2. Do not change the engine speed during this time.
3. Extend and retract each cylinder several times and lightly operate the swing and travel motors to warm up them.
4. Extend the bucket cylinder to the stroke end.
5. Be sure not to hold the bucket lever in this position for more than 30 seconds.
6. Retract the bucket cylinder to the other stroke end.
7. Be sure not to hold the bucket lever in this position for more than 30 seconds.
8. Repeat steps 4. to 7. until the bucket cylinder cycle time becomes normal.

OPERATING THE MACHINE

PRECAUTIONS FOR OPERATIONS

- !** **CAUTION:** Investigate the work site before starting operations.
- Be sure to install an overhead cab guard when operating in a work site which has a possibility of falling objects.
 - If operation on soft ground is required, sufficiently reinforce the ground beforehand.
 - Be sure to wear close fitting clothing and safety equipment appropriate for the job, such as a hard hat, etc. when operating the machine.
 - Clear all persons and obstacles from area of operation and machine movement.
Always beware of the surroundings while operating. When working in a small area surrounded by obstacles, take care not to hit the upperstructure against obstacles.
 - When loading onto trucks, bring the bucket over the truck beds from the rear side. Take care not to swing the bucket over the cab or over any person.

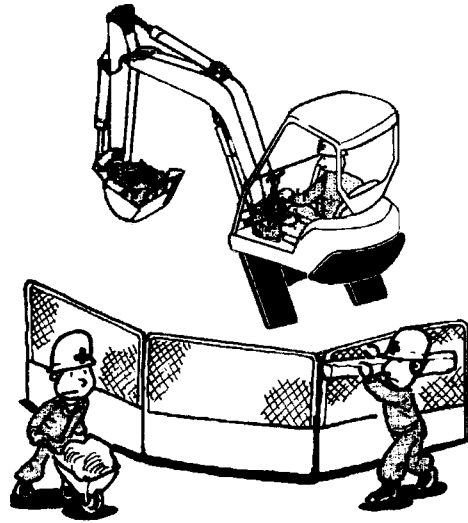

M586-12-012

OPERATING THE MACHINE

AVOID TIPPING

⚠ CAUTION: Operating on slopes is dangerous. Reduce operating speeds to avoid tipping or slipping.

1. To the extent possible, avoid turning on slopes. When you must turn on a slope, try to do so in an area with solid footing and not so steep.
2. Avoid crossing slopes as there is always a danger of tipping over.
3. Never travel on a slope if its steepness is more than 25 degrees longitudinally.
4. Don't swing downward on a slope as doing so may overturn the machine.

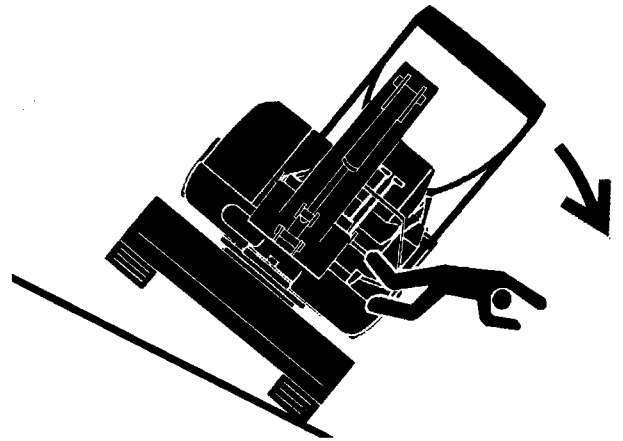

SA-670

OPERATING THE MACHINE

OPERATING BACKHOE

1. Place the bucket teeth on the ground with the bottom of the bucket at a 45° degree angle to the ground.
2. Pull the bucket toward the machine using the arm as the main digging force.
3. When soil sticks to the bucket, remove it by moving the arm and/or bucket rapidly back and forth.
4. When trenching a straight line, position the tracks parallel to the trench. After digging to the desired depth, move the machine as required to continue the trench.

IMPORTANT:

- When lowering the boom, avoid sudden stops that may cause shock load damage to the machine.
- When operating the arm, avoid bottoming the cylinder to prevent cylinder damage.
- When digging at an angle, avoid striking the tracks with the bucket teeth.
- When digging a deep excavation, avoid striking the boom or bucket cylinder hoses against the ground.
- When digging with the blade positioned towards the front or when digging at an angle, avoid hitting the blade.

TAKE CARE NOT TO HIT THE BUCKET TEETH

When digging hard surfaces, mainly use hydraulic power. Applying too much striking force to the Bucket teeth, will cause them to wear out prematurely.

Remember that jacking up on the Bucket teeth will put undue pressure on the teeth and the track-frame, causing structural damage. For this reason, do not jack up on the bucket teeth.

When digging , use the boom, arm and bucket, and take care not to dig too deep. Keeping this in mind will help prevent damage to your machine and will improve your productivity as well.

OPERATING THE MACHINE

GRADING OPERATION

In most cases, use the blade for soil refilling and general grading operations. When needed, the front attachment can be used to perform grading operations.

IMPORTANT: Don't pull or push dirt with the bucket when traveling.

Position the arm slightly forward of the vertical position with bucket rolled back, as shown.

Operate arm roll-in function while slowly raising the boom. Once the arm moves past the vertical position slowly lower the boom to allow the bucket to maintain a smooth surface.

Grading operation can be more precisely done by operating the boom, arm and bucket simultaneously.

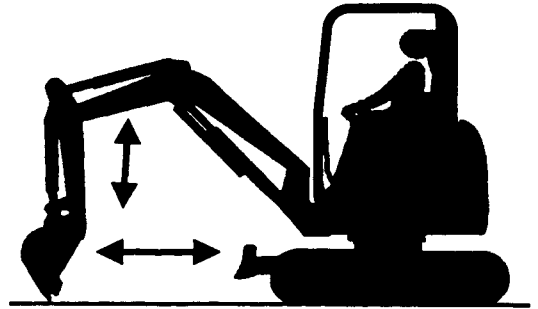

M586-05-013

AVOID ABUSIVE OPERATION

Don't use travel as an additional digging force. Severe machine damage may result.

Don't raise rear of machine to use the machine's weight as additional digging force. Severe machine damage may result.



WRONG



WRONG

M586-05-014

OPERATING THE MACHINE

SELECT CORRECT TRACK SHOES

Rubber and marsh shoes are only for use on soft ground, not on hard, abrasive surfaces such as gravels, rocks, minerals, etc.

Using these shoes on such surfaces can cause shoes to be damaged or warped, and further cause damage to the track link and/or rollers.

OPERATING TIPS

Don't hit track with bucket when digging.

Whenever possible, position your machine on a level surface.

Don't use the bucket as a hammer or pile driver. Do not attempt to shift rocks and break walls using swing motion.

IMPORTANT: Don't strike the ground with the bucket or use the bucket for tamping with the bucket cylinder fully extended (the bucket completely curled under) to avoid damaging cylinders.

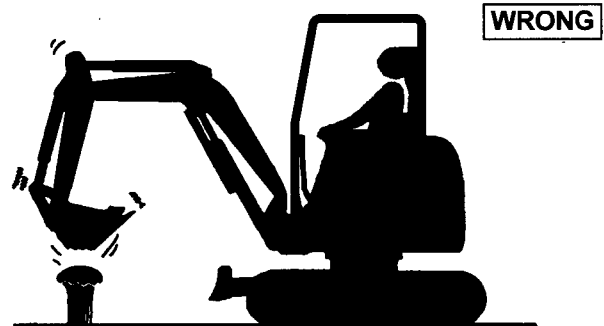

M586-05-015

Adjust the length and depth of each cut to produce a full bucket at every pass.

Full loads on every pass is more productive than a faster cycle with a partially filled bucket.

Full load should be the first objective, followed by speed, to increase productivity.

IMPORTANT: Don't attempt to break ledge rock by extending the arm to maximum reach and dropping the front of the bucket on the bucket teeth for penetration. Serious damage to the machine can result.

Once the trench is open, ledge rock can be broken by pulling the bucket up under the layers. The top layers are pulled out first, with one or two layers being lifted at a time. Don't sideload bucket. For example, do not swing bucket to level material or do not strike objects from the side with the bucket.

OPERATING THE MACHINE

OBJECT HANDLING --- IF EQUIPPED



CAUTION: When you use machine for object handling, be sure to comply with all local regulations.

Cables, straps, or ropes can break, causing serious injury. Don't use damaged chains, frayed cables, slings, straps, or ropes to crane.

Never move the load quickly. Never move load over a person's head. Don't allow any persons near load.

Keep all persons away from wire-rope-attached load, lifted or sitting on ground unless it is securely sitting on blocks or on the ground.

Position upperstructure so that the travel motors are at the rear.

Don't attach sling/chain to the bucket teeth.

- Secure sling/chain tightly to the load to be lifted. Wear gloves when securing sling/chain.
- Fasten sling/chain to bucket loop, with the bucket curled and arm retracted.
- Coordinate hand signals with your signal man before starting.
- Be aware of the location of all persons in the working area.
- Attach a hand line to load and make sure person holding it is well away from load.
- Before lifting, test your load.
 - Park your machine close to load.
 - Attach load to the machine.
 - Raise load 50 mm (2 in) above the ground.
 - Swing the load all the way to one side.
 - While keeping load close to the ground, move it away from machine.
 - If there is any indication of reduced stability of your machine, lower load to the ground.
- Lift load only as high as necessary.

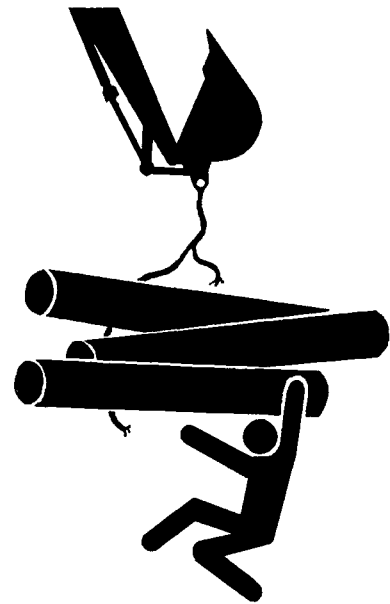

SA-014

OPERATING THE MACHINE

AVOID HITTING BLADE WITH FRONT ATTACHMENT

When operating the machine with the blade positioned towards the front, the bucket or boom cylinder may come into contact with the blade if you are not careful. Be sure to prevent this from happening.

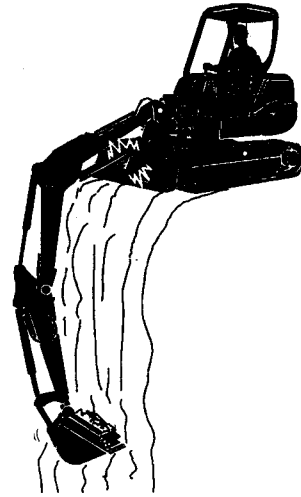

M586-05-016

AVOID HITTING BLADE WITH BUCKET

When crowding the arm into a traveling or transporting position, be careful not to let the bucket hit the blade.

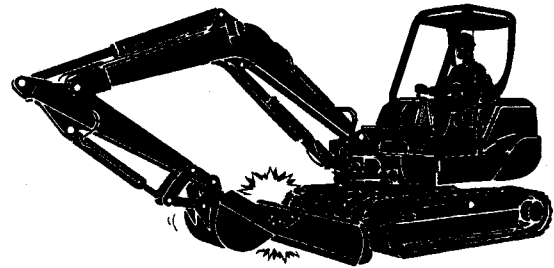

M586-05-017

AVOID STRIKING THE BLADE INTO A ROCK

Don't attempt to strike large rocks with the blade, as doing so will damage the blade and the blade cylinders, shortening their operating lives.

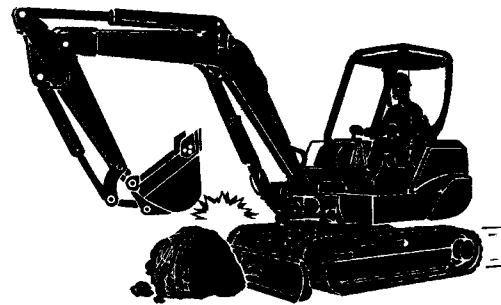

M586-05-035

OPERATING THE MACHINE

BOOM CYLINDER MAY HIT TRACK

IMPORTANT: When digging deeply with the front attachment positioned at an angle, as illustrated, the boom cylinder may accidentally hit the track, causing damage. Take extra care to prevent this from happening.



M586-05-018

PRECAUTIONS FOR INSTALLING WIDE BUCKET OR SPECIAL TYPE BUCKET

If the boom is fully offset to the left and raised with a wide width bucket installed, the bucket will come in contact with the cab or canopy. Be sure to install the bucket having the width dimensions shown below or less:

ZAXIS30:	600 mm (24in)
ZAXIS35:	650 mm (26in)
ZAXIS40:	700 mm (28in)
ZAXIS50:	700 mm (28in)

OPERATING THE MACHINE

OPERATE THE MACHINE SAFELY



CAUTION: Prevent the machine from tipping over and from being involved in a ground collapse. Take the necessary precautions as follows:

- Make sure the work site has sufficient strength to firmly support the machine. When working close to an excavation or on road shoulders, operate the machine with the tracks positioned perpendicular to the cliff face with travel motors at the rear and with the blade at the front, so that the machine can more easily evacuate if the cliff face collapses.
- If working on the bottom of a cliff or a high bank is required, be sure to investigate the area first and confirm that no danger of the cliff or bank collapsing exists. If any possibility of cliff or bank collapsing exists, do not work on the area.
- Soft ground may collapse when operating the machine on it, possibly causing the machine to tip over. When working on a soft ground is required, be sure to reinforce the ground first using large pieces of steel plates strong and firm enough to easily support the machine.
- Note that there always is a possibility of machine tipping over when working on rough terrain or on slopes. Prevent machine tipping over from occurring. When operating on rough terrain or on slopes:
 - Reduce the engine speed.
 - Select slow travel speed mode.
 - Operate the machine slowly and be cautious with machine movements.

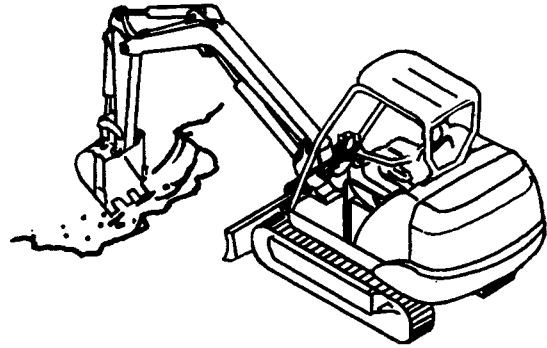

M586-05-021

OPERATING THE MACHINE

USING RUBBER CRAWLER

Rubber crawlers are designed for traveling on paved roads. Avoid damage to the rubber crawlers by following the precautions below:

Forbidden Operations

Don't operate on sharp, rocky, uneven surfaces, such as river rock, gravel, etc.

Don't allow engine oil, gasoline, etc. to remain on the track, and avoid traveling in oil in order to reduce the danger of slipping.

Don't travel using the track of one side only with the other track jacked up by the front attachment.



M586-05-022

OPERATING THE MACHINE

TRAVELING AND OTHER CAUTIONS



CAUTION: The rubber crawler machine is less stable than the steel crawler machine, as the edge of the rubber crawler may deform when loaded. Pay attention when digging with the boom positioned at a right angle to the tracks.

- Do not keep the rubber crawler under direct sunlight for more than three months.
- Avoid reckless steering operations on concrete road to the extent possible, as this will cause wear to the shoe lug. Also, avoid running on asphalt road of more than 60°C (140°F) in temperature, as this will cause wear to the shoe as well as damage to the road surface.
- Running with a loose track on uneven surfaces can result in sudden separation and/or damage of the track.
- Ease the machine down from the jacked-up position. Do not let it drop.
- The rubber track has a thin rubber film on its inner surfaces, as shown, when it is new. In a new machine, the rubber film may come off while being rubbed against rollers. This is not abnormal.

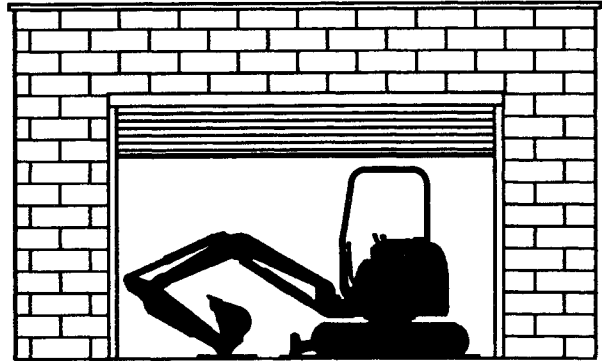

M586-05-023

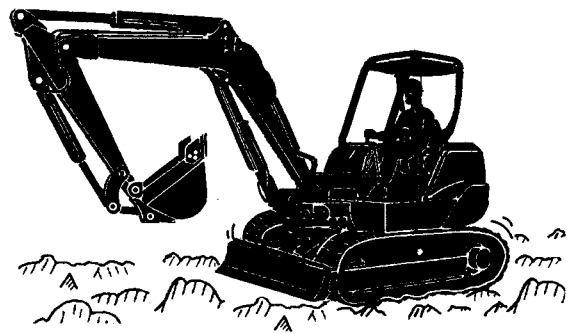

M586-05-024

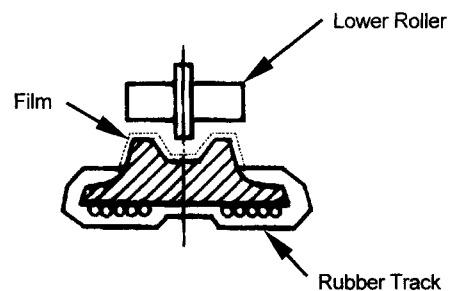

M503-05-040

OPERATING THE MACHINE

EMERGENCY STOP PROCEDURE TO LOWER FRONT ATTACHMENT

- !** **CAUTION:** Prevent personal injury. Confirm that no one is under the front attachment before starting the procedure below. If an accident occurs, get immediate medical attention. Any fluid injected into the skin must be surgically removed within a few hours or gangrene may result.

If the engine stalls and cannot be restarted, lower the boom to lower the bucket to the ground referring to the emergency boom lowering procedure stated below.

- !** **CAUTION:** Keep workers from entering the area under the front attachment.

1. Release air pressure from the hydraulic oil tank by loosening cap (1) located on the top of the tank.
2. Remove the floor plate to access the control valve.

- !** **CAUTION:** Slowly loosen the cartridge (2) while checking the lowering speed of the front attachment. Failure to do so may cause the boom to quickly fall.

IMPORTANT: Do not use a ratchet spanner as loosening and re-tightening the cartridge must be quickly repeated.

3. While holding the hexagonal section of overload relief valve cartridge (2) located on the boom cylinder bottom side, slowly loosen the relief valve cartridge. The boom cylinder bottom side port in the control valve is routed to the hydraulic tank passage, allowing the boom to lower.

Tool : 22 mm
Torque : 40 N·m (4.1 kgf·m)

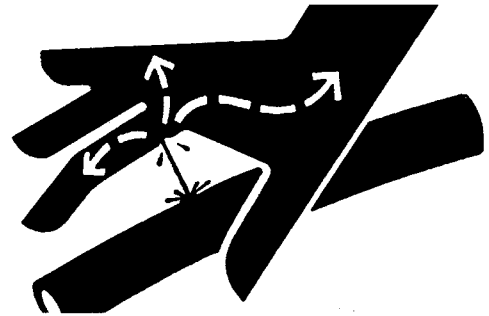

SA-031

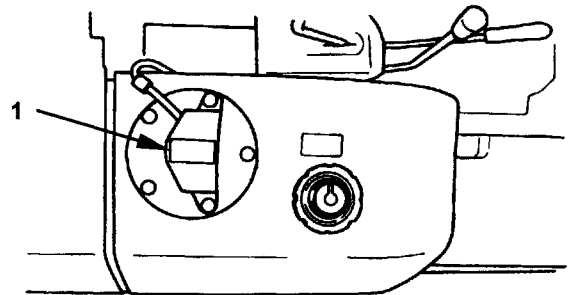

M585-07-024

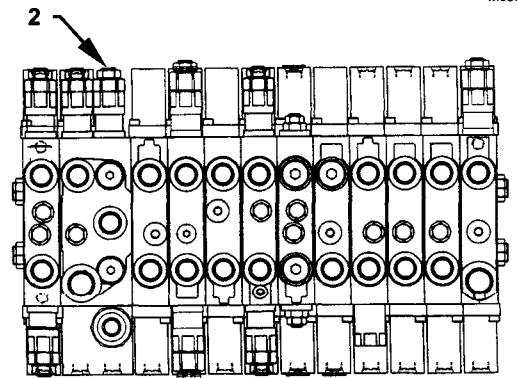

ZAXIS30, 35

T1LA-03-03-001

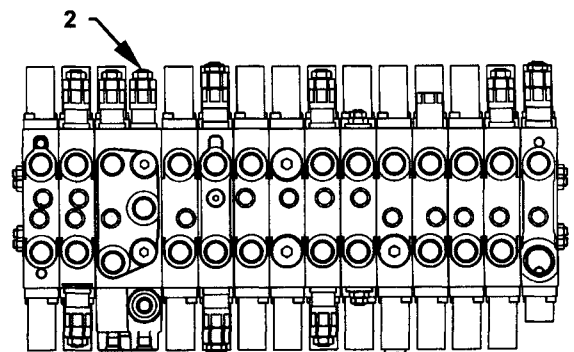

ZAXIS40, 50

M1LS-05-002

OPERATING THE MACHINE

HYDRAULIC BREAKER OPERATING TIPS --- IF EQUIPPED

Select a breaker that is the correct size and weight for your machine. See your authorized dealer for correct breaker information.

Carefully study the operator's manuals of the machine and breaker, and perform the required checks and/or inspection before connecting the breaker to the arm.

Precautions for Connecting Breaker Piping

1. When the breaker is not used, apply cover to the pipe end on the arm top and install plug into the hose end of the breaker to prevent entry of contamination into the system.
2. Be sure to provide spare covers and plugs in the tool box so that they will be available when needed.
3. Avoid allowing contamination to enter into the system when switching the breaker with the bucket.
4. After connecting, check the connecting seal fitting for oil leakage, and pipe clamp bolts for looseness.

Precautions for Hydraulic Breaker Operation

Perform the required checks and inspection daily before operation.

CAUTION: A breaker is heavier than an excavation bucket. Stability will be reduced when operating the machine with breaker attachment. In addition, hydraulic breaker operation may cause soil and dust to scatter, and fragments of rocks and broken pieces of metal to fly. Take necessary precautions to prevent the machine from tipping over and avoid potential accidents. Also, observe the following precautions to avoid damage to the machine as well as to avoid potential accidents.

- Since the hydraulic breaker is heavier than the bucket, lowering of the front attachment is faster with the hydraulic breaker attached. Do not hit the breaker hard against the hard materials (e.g. rocks, concrete, etc.). Doing so will damage the front attachment as well as the upperstructure.
- Do not use any part of the hydraulic breaker to move rocks or other heavy materials, or machine damage may result. Never move objects, in particular, using the breaker mounting bracket by swinging the upperstructure. Doing so will cause damaging the front attachment as well as the breaker.

WRONG

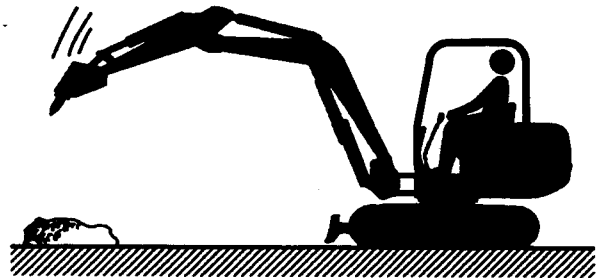

M586-05-025

WRONG

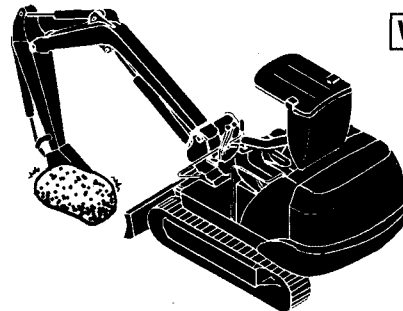

M586-05-020

OPERATING THE MACHINE

- Do not operate the breaker with the hydraulic cylinder rod fully retracted or fully extended. Doing so may cause cylinder or machine damage. Always leave at least 50 mm (2 in.) from the fully retracted/extended position in order to reduce shocks.

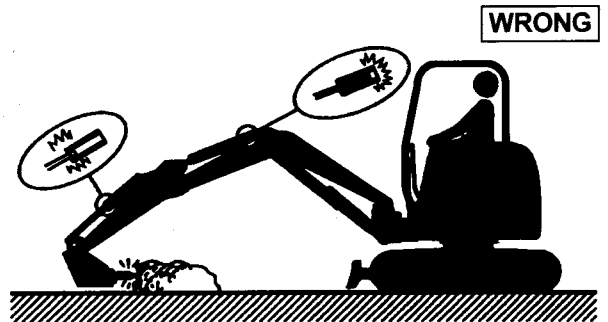

M586-05-027

- Do not operate the breaker in water. Doing so will cause rust and seal damage, resulting in damage to the hydraulic system components.

IMPORTANT: When working in water, be sure to use a water-tight hydraulic breaker.

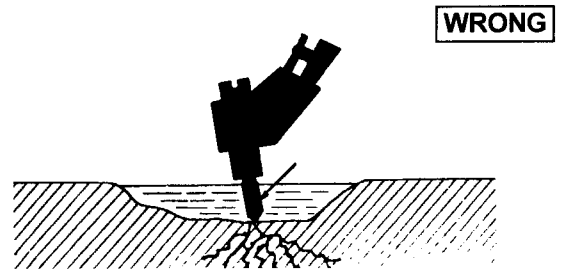

M104-05-059

- Do not attempt to lift objects with the breaker attached. Doing so may result in machine damage or tipping over.

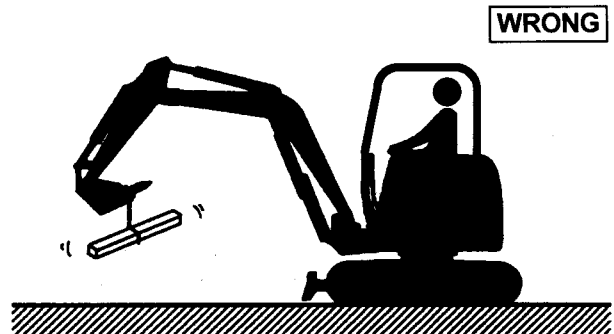

M586-05-028

- Operate breaker only with the front attachment aligned with the side tracks, as illustrated. Operating the breaker on either side of the machine may cause instability and shortened undercarriage component service life.

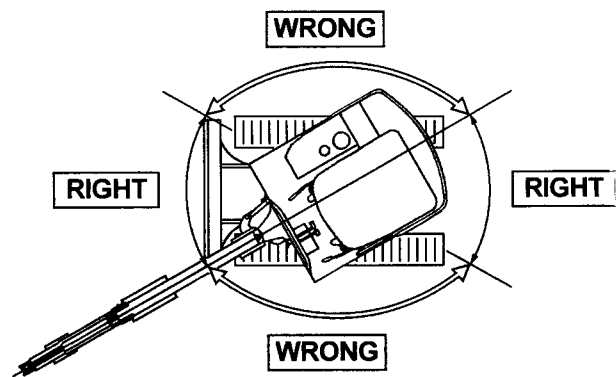

M503-05-080

OPERATING THE MACHINE

- Be careful not to hit the breaker against the boom when operating the arm roll-in and bucket (breaker) roll-in functions.

WRONG



M586-05-029

REPLACEMENT OF HYDRAULIC OIL AND FILTER ELEMENT

Using the hydraulic breaker subjects the machine's hydraulic system to possible contamination and accelerated deterioration. Hydraulic filter elements and hydraulic oil must be replaced more often than with ordinary digging attachment in order to prevent damage to hydraulic pumps and other hydraulic components. Recommended replacement intervals are as shown below.

Replacement Interval (hours)		
	Hydraulic Oil	Filter Element
Machine with Ordinary Bucket	1000	500
Machine with Hydraulic Breaker	500	100

NOTE: Replacement intervals shown here are for 100% bucket or breaker application. When breaker/bucket applications are alternated, replacement intervals may be extended, depending upon the percent of time the bucket is applied.

OPERATING THE MACHINE

OPERATING HYDRAULIC CRUSHER --- IF EQUIPPED

Select a crusher that is the correct size and weight for the machine. See your authorized dealer for correct crusher information.

The crusher is much heavier than the bucket. Operate the machine slowly to prevent tipping the machine. Also, keep the following precautions in mind.

Precautions for Crusher Operation

CAUTION: A crusher is heavier than an excavation bucket. Stability will be reduced when operating the machine with crusher attachment. In addition, hydraulic crusher operation may cause debris to fall, soil and dust to scatter, and fragments of rocks and broken pieces of metal to fly. Take necessary precautions to prevent the machine from tipping over and avoid potential accidents. Also, observe the following precautions to avoid damage to the machine as well as to avoid potential accidents.

- Do not allow the machine's weight to be supported by the crusher or bucket cylinder with the bucket cylinder fully extended or retracted. Doing so may damage the front attachment. In particular, avoid doing so with the bucket cylinder fully extended, as the front attachment will be easily damaged. Take care to prevent this from happening when dismantling foundation structures using the crusher.
- Do not attempt to perform crushing on either side of the machine. Always perform crushing operations to the fore or rear, parallel with the tracks. Otherwise, tipping over may occur.

WRONG

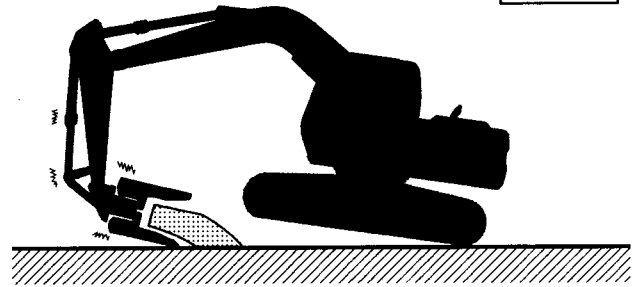

M107-05-046

WRONG

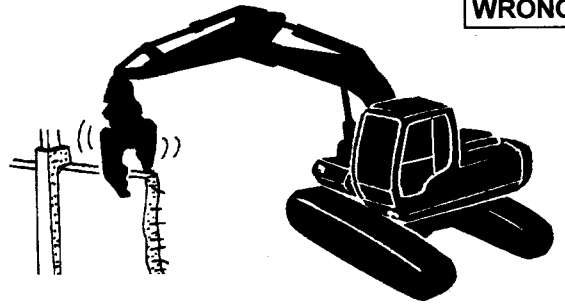

M107-05-047

OPERATING THE MACHINE

- When operating the crusher up high with the boom fully raised, be careful of falling objects.

IMPORTANT: If a hydraulic breaker is operated with the bucket cylinder fully retracted, damage to pins and links at the end of the front attachment may result. Never use an attachment heavier than the allowable weight.

- When operating the crusher on a floor in a building, first confirm that the floor has sufficient strength to support the load caused by crushing, in addition to the machine weight.
- Always operate the crusher on a stable, level surface, not on a slope or on crushed scraps.
- Do not use the crusher to haul or load crushed scraps.
- Frequent replacing of the bucket with the crusher or breaker subjects the machine's hydraulic system to possible contamination and accelerated deterioration. Replace hydraulic filter elements and hydraulic oil more often than when simply digging, to prevent damage to hydraulic pumps and other hydraulic components. Refer to "Operating the Hydraulic Breaker" in this section for replacement intervals.
- Always remove the crusher from the excavator before transporting the machine. Do not fully extend the bucket cylinder when transporting, as this may damage the front attachment, when vibrations arise during transportation.



M107-05-048

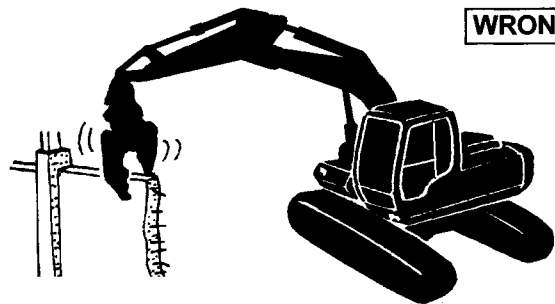

M107-05-047

AFTER FINISHING WORK

1. Find a safe, level place to park, with no danger of falling rocks or other debris. Be sure to lower the bucket and blade to the ground.
2. Fill the tank with fuel.
3. Clean the machine thoroughly.



SA-675

TRANSPORTING

TRANSPORTING BY ROAD

When transporting the machine on public roads, be sure to first understand and follow all local regulations.

1. For transporting using a truck, check the width, height, length and weight of the truck when the machine is loaded.
2. Investigate beforehand the conditions of the route to be traveled, such as dimensional limits, weight limits, and traffic regulations.

In some cases, disassemble the machine to bring it within dimensional limits or weight limits as local regulations.

TRANSPORTING THE MACHINE BY TRUCK

Provide an appropriate truck, referring to the dimensions of the machine in the transport position, as shown in the Specifications section.

When using the truck, consult your authorized dealer for details.

LOADING/UNLOADING ON A TRAILER

Always load and unload the machine on a solid, level surface.



CAUTION: Be sure to use a loading dock or a ramp for loading/unloading.

Ramp/Loading Dock:

1. Before loading, thoroughly clean the ramp and flatbed. Dirty ramps or flatbeds with oil, mud or ice on them are slippery and dangerous.
2. Place blocks against the truck wheels while using a ramp or loading dock.
3. Ramps must be sufficient in width, length, and strength. Be sure that the incline of the ramp is less than 15 degrees.
4. Loading docks must be sufficient in width and strength to support the machine and have a gradient of less than 15 degrees.

TRANSPORTING

Loading/Unloading

CAUTION:

- **Avoid steering while driving up or down a ramp as it is extremely dangerous. If steering is unavoidable, first move back to the ground or flatbed, modify traveling direction, and begin to drive again.**
- **The top end of the ramp where it meets the flatbed is a sudden bump. Take care when traveling over it.**
- **Prevent possible injury from machine tipping while the upperstructure is rotating. Keep the arm tucked under and rotate the upperstructure slowly for best stability.**

Loading

1. The machine direction should be as follows:

With the front attachment: Travel forward with the front attachment at the front.

Without the front attachment: Travel in reverse.

2. The centerline of the machine should be over the centerline of the truck.
3. Drive the machine onto the ramp slowly.

With the front attachment:

- Position the bucket with its flat surface resting on the truck. Angle of the arm to boom should be 90 to 110°.
 - Rest the bucket on the truck just before the machine begins to tip forward onto the truck. Slowly travel forward until the tracks are firmly on the truck.
 - Slightly raise the bucket. Keeping the arm tucked under, slowly rotate the upperstructure 180°.
 - Lower the bucket onto blocks.
4. Stop the engine. Remove the key from the switch.
 5. Move the control levers several times until hydraulic pressure in the cylinders is released.
 6. Pull the pilot control shut-off lever to LOCK position.
 7. Close cab windows, roof vent and door, to prevent entry of wind and water.

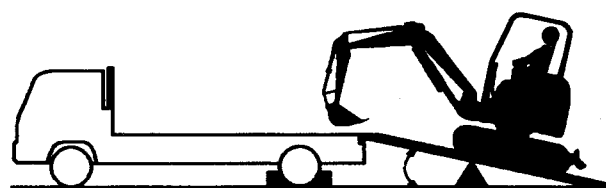

Less than 15°

M586-06-001

 **NOTE:** *In cold weather, be sure to warm up the machine before loading or unloading it.*

TRANSPORTING

Transporting

CAUTION: Fasten chains or cables to the machine frame. Do not place chains or cables over or against the hydraulic lines or hoses.

- Place blocks in front of and behind the tracks.
- Fasten each corner of the machine and front attachment to the truck with a chain or cable.

PRECAUTIONS FOR TRANSPORTING MACHINES WITH RUBBER TRACKS

When transporting a machine with rubber tracks, be sure to fasten the right and left track frames securely to the flatbed with wire ropes and soft protectors, as shown.

Do not allow wire ropes to come into direct contact with rubber tracks.

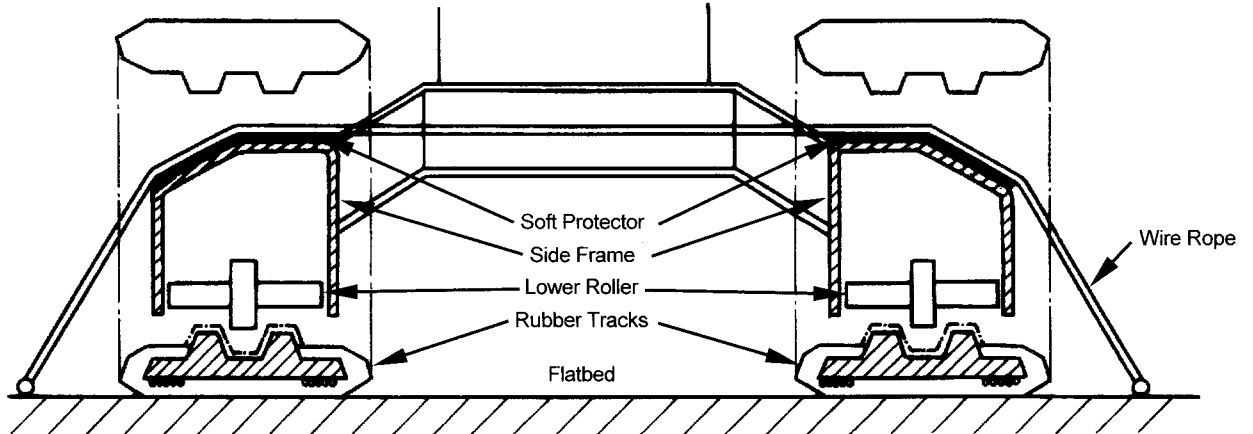

M552-06-001

TRANSPORTING

Unloading

CAUTION: The rear end of the flatbed where it meets the ramp is a sudden bump. Take care when traveling over it.

IMPORTANT: Prevent possible damage to the front attachment. Always position the arm at 90° to the boom when unloading the machine. Unloading the machine with the arm tucked in may cause machine damage.

1. To move the machine over end of the truck onto the ramp, rest the flat surface of the bucket on the ground. Angle of the arm to the boom should be 90 to 110°.

IMPORTANT: Prevent possible damage to the hydraulic cylinders. Do not allow the machine to hit the ground hard with the bucket.

2. The bucket must be on the ground before the machine begins to tip forward.
3. As the machine moves forward, raise the boom and extend the arm until the machine is completely off the ramp.

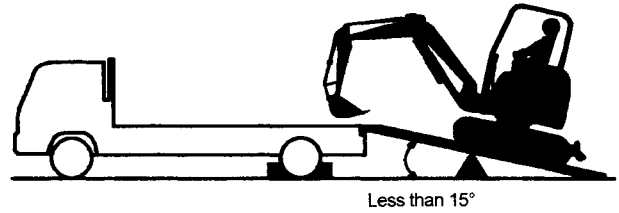

M586-06-001

TRANSPORTING

LIFTING THE ENTIRE MACHINE WITH A CRANE

USING EYE PLATES ON BOOM AND BLADE



CAUTION:

- Do not allow anyone to ride on the machine while it is being lifted.
- Use wire ropes of sufficient strength to bear the weight of the machine.
- Check the canopy/cab mounting bolts for looseness.

Wrench size

24 mm

Tightening torque

210 N·m (21 kgf·m)

1. Swing the upperstructure so the blade is positioned towards the rear, as illustrated.



CAUTION: Be sure to operate the blade while the engine is running. If the blade is operated after the engine stopped, the blade will drift when lifting the machine.

2. Fully retract the blade cylinder.
3. Position the front attachment as follows:
Fully extend the boom, arm and bucket cylinders.
(See illustration)
4. Pull the pilot control shut-off lever to LOCK position.
5. Position the boom straight ahead of the upperstructure. Apply the boom swing pedal lock.
6. Attach wire ropes to the eyeplates, one on the boom and two on the blade, using shackles.
7. Slowly lift the entire machine. Be sure to maintain the machine's balance.

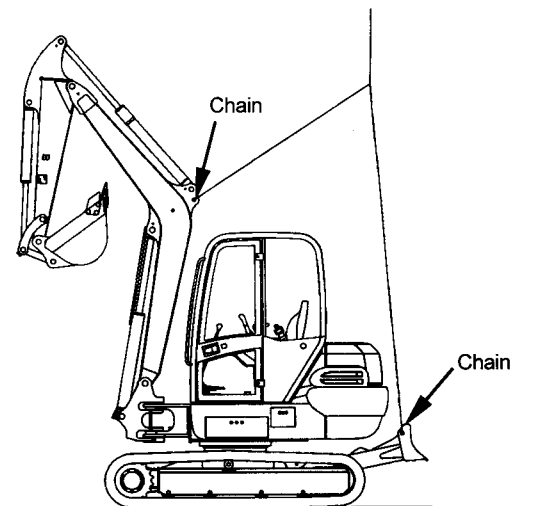

Before lifting

M1LS-06-001

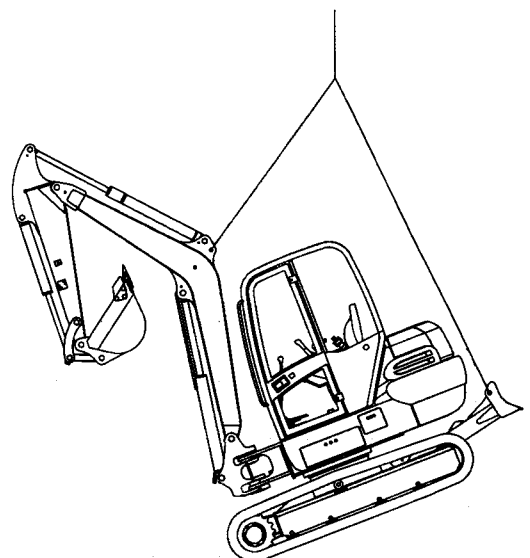

M1LS-06-002

TRANSPORTING

MEMO

Dotted lines for writing content.

MAINTENANCE

CORRECT MAINTENANCE AND INSPECTION PROCEDURES

Learn how to service your machine correctly. Follow the correct maintenance and inspection procedures shown in this manual.

Inspect machine daily before starting.

- Check controls and instruments.
- Check coolant, fuel and oil levels
- Check for leaks, kinked, frayed or damaged hoses and lines.
- Walk around machine checking general appearance, noise, heat, etc.
- Check for loose or missing parts.

If there is any problem with your machine, repair it before operating or contact your authorized dealer.

- IMPORTANT:**
- **Use only recommended fuel and lubricants.**
 - **Use only genuine HITACHI parts.**
 - **Failure to use recommended fuel, lubricants, and genuine Hitachi parts will result in loss of Hitachi product warranty.**
 - **Never adjust engine governor or hydraulic system relief valve.**
 - **Protect electrical parts from water and steam.**
 - **Never disassemble electrical components such as sensors, etc.**



SA-435

MAINTENANCE

SERVICE YOUR MACHINE AT SPECIFIED INTERVALS

Perform all service procedures described in this maintenance guide.

Lubricate, make service checks and adjustments at intervals shown on the periodic maintenance chart located on the right side of oil/fuel tank.

CHECK THE HOUR METER REGULARLY

Check hour meter (1) to determine when your machine needs periodic maintenance.

Intervals on the periodic maintenance chart are for operating in normal conditions. If you operate your machine in more adverse conditions, you should service it at **SHORTER INTERVALS**.

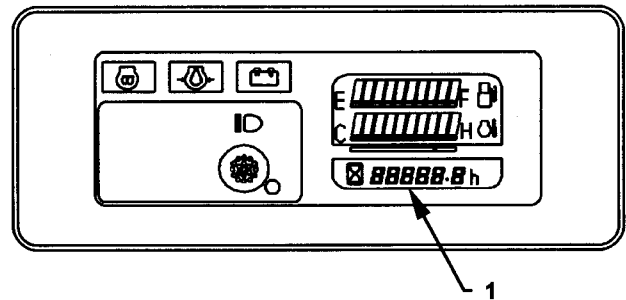

M586-01-014

MAINTENANCE

PREPARE MACHINE FOR MAINTENANCE

Before performing the maintenance procedures given in the following chapters, park the machine as described below, unless otherwise specified.

1. Park the machine on a level surface.
2. Lower the bucket and blade to the ground.
3. Run the engine at slow idle speed without load for 5 minutes.
4. Turn the key switch OFF. Remove key from switch. (If maintenance must be performed with engine running, do not leave machine unattended.)
5. Pull the pilot control shut-off lever (1) to the LOCK position.
6. Before performing any work on the machine, attach a "Do Not Operate" tag on the right control lever.

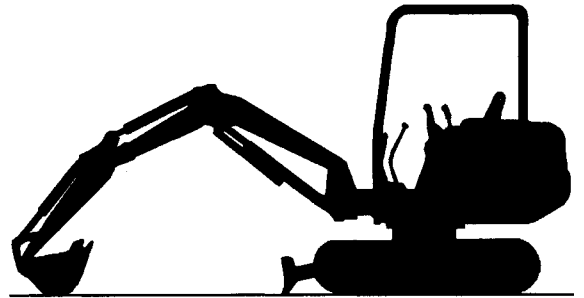

SA-675

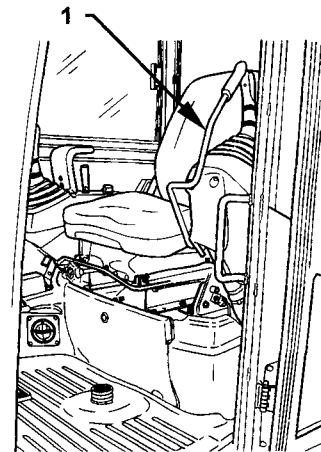

LOCK Position

M1LS-03-001



SS2045102

MAINTENANCE

HOOD AND ACCESS COVERS

CAUTION: Do not keep the hood and access covers open when the machine is parked on a slope, or while the wind is blowing hard. The hood or access covers may close accidentally, possibly resulting in personal injury.

- Secure Engine Hood in Position
Pull open latch to unlock hood (1).
Raise hood (1) until the end of bar (2) is securely locked into catch (3).

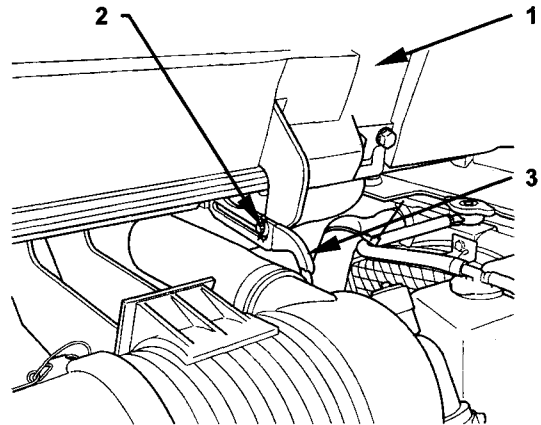

ZAXIS30, 35

M1LS-07-006

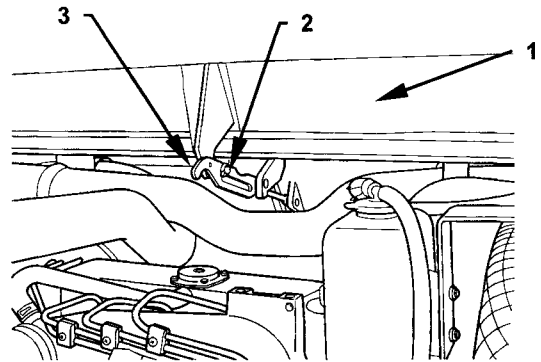

ZAXIS40, 50

M1LS-07-007

MAINTENANCE

DAILY INSPECTION

- 1- Tooth
- 2- Side Cutter
- 3- Bucket
- 4- Bucket Cylinder
- 5- Arm
- 6- Arm Cylinder
- 7- Boom
- 8- Canopy(Cab)
- 9- Swing Bearing
- 10- Boom-Swing Cylinder
- 11- Battery
- 12- Swing Device
- 13- Fuel Tank/Hydraulic Oil Tank
- 14- Radiator, Oil Cooler
- 15- Counterweight
- 16- Engine
- 17- Track
- 18- Air cleaner
- 19- Engine Oil Filter
- 20- Muffler
- 21- Hydraulic Pump
- 22- Travel Device
- 23- Lower Roller
- 24- Track Frame
- 25- Center Joint
- 26- Upper Roller
- 27- Track Adjuster
- 28- Control Valve
- 29- Front Idler
- 30- Blade Cylinder
- 31- Blade
- 32- Control Lever
- 33- Boom Cylinder
- 34- Work Light

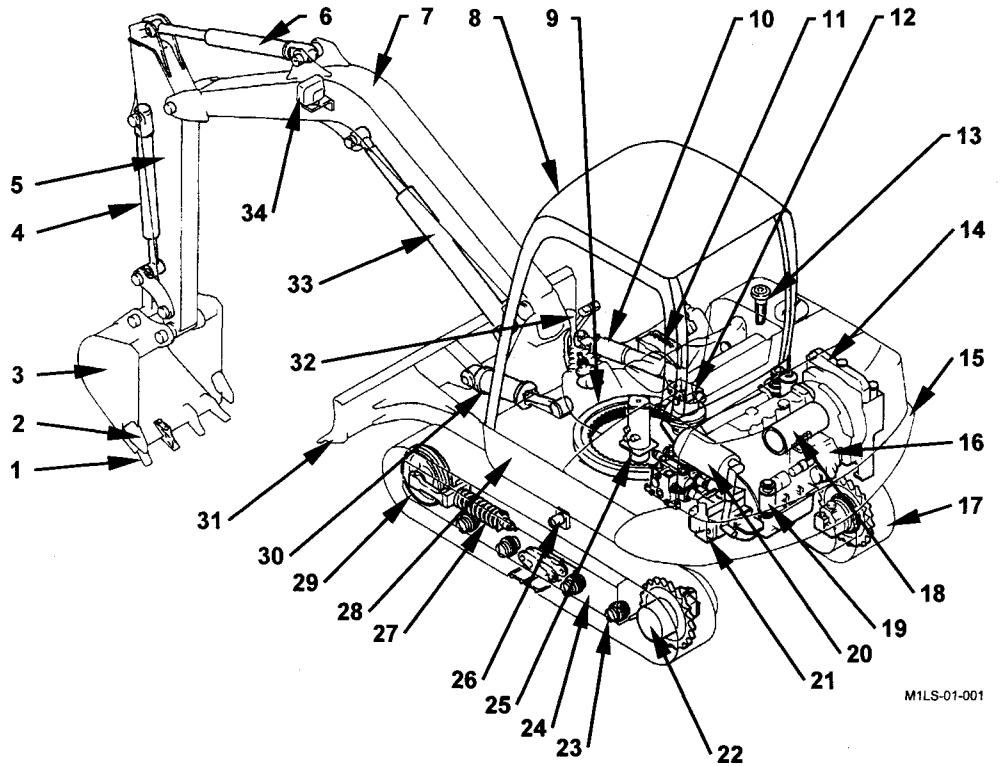

M1LS-01-001

MAINTENANCE

DAILY INSPECTION CHECK LIST

	Checkpoint
Engine	<ol style="list-style-type: none"> 1. Oil and coolant quantity, contamination. 2. Rough engine operation, exhaust gas color, abnormal noise. 3. Oil and coolant leakage. Damaged hoses and pipes. 4. Clogged or damaged radiator/oil cooler. 5. Loose or missing bolts and nuts.
Upper-structure	<ol style="list-style-type: none"> 1. Fuel level, leakage, any foreign materials. 2. Hydraulic oil level, leakage, any foreign materials. 3. Control lever movement, lever play, abnormal operating force. 4. Correct hydraulic components activation. Damaged hoses and pipes, oil leakage. 5. Damaged or deformed components. Abnormal noise. 6. Loose or missing bolts and nuts. 7. Windshield washer liquid.
Under-carriage	<ol style="list-style-type: none"> 1. Track sag. Worn or damaged track shoes. 2. Worn or oil leakage of lower roller, upper roller, front idler. 3. Travel device oil leakage. 4. Loose or missing bolts and nuts.
Front Attachment	<ol style="list-style-type: none"> 1. Damaged cylinders, hoses and pipes. Oil leakage. 2. Damaged or worn bucket and blade. 3. Loose, worn or missing teeth. 4. Grease lubrication for front joint pins. 5. Damaged lock pins, stoppers, fastener rings and lock bolts for front joint pins. 6. Loose or missing bolts and nuts.
Miscellaneous	<ol style="list-style-type: none"> 1. Gauges, monitors, lights, buzzer functioning. 2. Canopy deformations or damages. 3. Abnormalities in machine appearance.

MAINTENANCE

PERIODIC REPLACEMENT OF PARTS

To ensure safe operation, be sure to conduct periodic inspection of the machine. In addition, the parts listed below, if defective, may pose serious safety/fire hazards. It is very difficult to gauge the extent of deterioration, fatigue, or weakening of the parts listed below simply by visual inspection alone. For this reason, replace these parts at the intervals shown in the table below. However, if any of these parts is found to be defective by inspection, replace it before starting operation, regardless of the interval.

Also, when replacing hoses, check their clamps for deformities, cracks, or other deterioration, and replace them as necessary.

Be sure to perform periodic inspection of all hoses, as shown below, and replace or retighten any defective parts found, as necessary.

Consult your authorized dealer for correct replacement.

Periodic Replacement Parts		Replacement Intervals	
Engine		Fuel hose (Fuel tank to filter)	Every 2 years
		Fuel hose (Fuel tank to injection pump)	Every 2 years
		Heater hose (Heater to engine)	Every 2 years
Hydraulic System	Basic Machine	Pump suction hose	Every 2 years
		Pump delivery hose	Every 2 years
		Swing hose	Every 2 years
	Front-End Attachment	Boom cylinder line hose	Every 2 years
		Arm cylinder line hose	Every 2 years
		Bucket cylinder line hose	Every 2 years
		Pilot hose	Every 2 years

 **NOTE:** Be sure to replace seals, such as O-rings and gaskets, along with the replacing hose.

MAINTENANCE

MAINTENANCE GUIDE

A. GREASING (See Page 7-11)

Parts	Quantity	Interval (hours)						
		8	50	100	250	500	1000	2000
1. Front Joint Pins	10							
2. Bucket and Link Pins	5	★						
3. Swing Bearing	1							
4. Swing Internal Gear	1							
5. Control Lever Universal Joint	2							

 NOTE: ★ Grease all submerged pins after operating in water.

B. ENGINE (See Page 7-17)

Parts		Quantity	Interval (hours)						
			8	50	100	250	500	1000	2000
1. Engine Oil	Oil Level Check	—							
2. Engine Oil	Change	ZAXIS30, 35	6.2 L (1.6 US gal)						
		ZAXIS40, 50	9.0 L (2.4 US gal)						
3. Engine Oil Filter	Replacement	1		★★					

 NOTE: ★★ For the first time only

C. TRANSMISSION (See Page 7-20)

Parts		Quantity	Interval (hours)						
			8	50	100	250	500	1000	2000
1. Travel Reduction Gear	Oil Level Check	2							
	Change	0.50 L (0.53 US qt) × 2							

D. HYDRAULIC SYSTEM (See Page 7-22)

Parts		Quantity	Interval (hours)						
			8	50	100	250	500	1000	2000
1. Check Hydraulic Oil Level		1							
2. Drain Hydraulic Oil Tank Sump		1							
3. Change Hydraulic Oil	ZAXIS30, 35	50 L (13.2 US gal)					★	★	
	ZAXIS40, 50	84 L (22.2 US gal)					★	★	
4. Clean Suction Filter		1	When changing hydraulic oil						
5. Replace Hydraulic Oil Tank Filter		1				★★			
6. Replace Pilot Filter		1							
7. Check Hoses and Lines	for leaks	—							
	for cracks, bend, etc.	—							

 NOTE: ★ Hydraulic oil changing intervals differ according to kind of hydraulic oils used. See recommended oil chart.

★★ For the first time only.

MAINTENANCE

E. FUEL SYSTEM (See Page 7-37)

Parts	Quantity	Interval (hours)						
		8	50	100	250	500	1000	2000
1. Drain Sediment Fuel Tank	1							
2. Check Water Separator	1							
3. Replace Fuel Filter	1							
4. Check Fuel Hoses	for leaks, cracks, etc.	-						
	for cracks, bend, etc.	-						

F. AIR CLEANER (See Page 7-41)

Parts	Quantity	Interval (hours)						
		8	50	100	250	500	1000	2000
1. Air Cleaner Element	Cleaning	1						★
	Replacement	1	After cleaning 8 times or 1 year					

 **NOTE:** ★ When the air cleaner elements are clogged.

G. COOLING SYSTEM (See Page 7-42)

Parts	Quantity	Interval (hours)						
		8	50	100	250	500	1000	2000
1. Check Coolant Level	1							
2. Check and Adjust Fan Belt Tension	1		★★					
3. Change Coolant	5.3 L (1.3 US gal)	★★★ Twice a year (in spring and autumn)						
4. Clean Radiator	Outside	1					★	
	Interior	1	When changing coolant					

 **NOTE:** ★ Shorten maintenance interval when the machine is operated in dusty areas.

★★ For the first time only.

★★★ When genuine long life coolant is used, replace it every two years or 2000 operating hours, whichever comes first.

H. ELECTRICAL SYSTEM (See Page 7-47)

I. MISCELLANEOUS (See Page 7-52)

Parts	Quantity	Interval (hours)						
		8	50	100	250	500	1000	2000
1. Check Bucket Teeth for Wear and Looseness	-							
2. Replace the Bucket	1	As required						
3. Check Track Sag (rubber crawler)	2							
4. Replace Rubber Track	2	As required						
5. Check Track Sag (steel crawler)	2							
6. Check and Replace Seat Belt	1		Every 3 years (Replace)					
7. Check Fuel Injection Nozzles	-							
8. Check and Adjust Value Clearance	-							
9. Check Injection Timing	-	As required						
10. Measure Engine Compression Pressure	-							
11. Check Starter and Alternator	-							
12. Check Radiator Cap	-	As required						
13. Check Tightening Torque of Bolts and Nuts	-		★★					

 **NOTE:** ★★ For the first time only

MAINTENANCE

THE BRAND NAMES OF RECOMMENDED OILS AND LUBRICANTS

Air Temp Manufacturer	Grease	Engine Oil			Gear Oil
	-20 to 40°C (-6 to 104°F)	-20 to 0°C (-6 to 32°F)	-10 to 35°C (14 to 95°F)	25 to 40°C (77 to 104°F)	-20 to 40°C (-6 to 104°F)
For New Machine	Japan Energy Resonic EP Grease 2	Idemitsu Kosan Aboll oil super wide 15W-40			Mitsubishi Diamond Hypoid Gear oil 90
British Petroleum	BP Energrease LS-EP2	BP Vanellus C3			BP Gear oil SAE 90 EP
		10W	30	40	
Caltex Oil	Multifax EP2	RPM DELO 300 C3			Universal Thuban SAE 90
		10W	30	40	
Esso	Beacon EP2	Essolube D-3			Esso Gear oil 90
		10W	30	40	
Idemitsu Kosan	Daphne coronex grease EP2	Apoll oil diesel motive			Apoll oil diesel motive S-330
		S-310	S-330	S-340	
		(-15 to 40°C) (5 to 104°F) Apoll oil custom wide 15W-40 Apoll oil super wide 15W-40			
Mobil Oil	Mobilux EP2	Mobil Delvac			Mobilube HD80W-90
		1310	1330	1340	
Nippon Oil	Epinoc Grease AP2	Hi-diesel S3			Gear Lube SP 90
		-20 to 35°C (-6 to 95°F) 10W-30	-10 to 40°C (14 to 104°F) 15W-40		
Shell Oil	Shell Alvania EP Grease 2	Rymla D			Shell Spirax EP 90
		10W	30	40	
Remarks		API CD CLASS			API GL4 class

Hydraulic Oil					Fuel Oil
Change Interval	2000 hours		1000 hours		
Air Temp	-20 to 0°C (-6 to 32°F)	-10 to 40°C (14 to 95°F)	-20 to 0°C (-6 to 32°F)	-10 to 40°C (14 to 95°F)	
Manufacturer					
Hitachi	* New Landy HN		Multi M		Use high quality Diesel Fuel only. ASTM2-D (JIS K-2204) Kerosene must not be used.
TOTAL			Equivis ZS46		
Idemitsu Kosan			Daphne Superhydro LW46H		
British Petroleum			Bartran HV46		
Caltex Oil			Rando Oil HD46		
Texaco INC.			Rando Oil HD46		
Chevron U.S.A INC			Chevron AW46		
Esso			NUTO H46		
Mobil Oil			DTE 25		
Shell Oil			Tellus Oil S46		

NOTE: The machine shipped from the factory is filled with oil marked *

MAINTENANCE

A. GREASING

- 1** Front Joint Pins --- every 500 hours or every years

Position machine with the arm cylinder fully retracted and the bucket cylinder fully extended. Lower bucket to the ground.



SA-675

- (1) Boom cylinder rod side

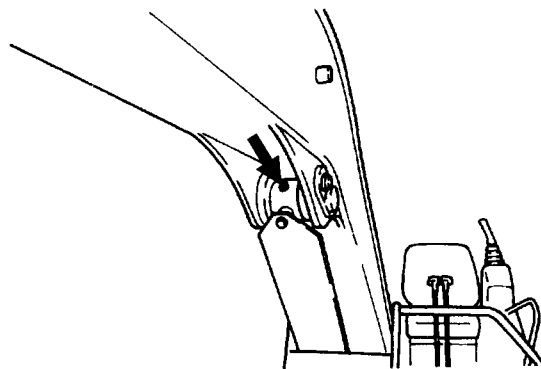

M585-07-003

- (2) Boom cylinder bottom side

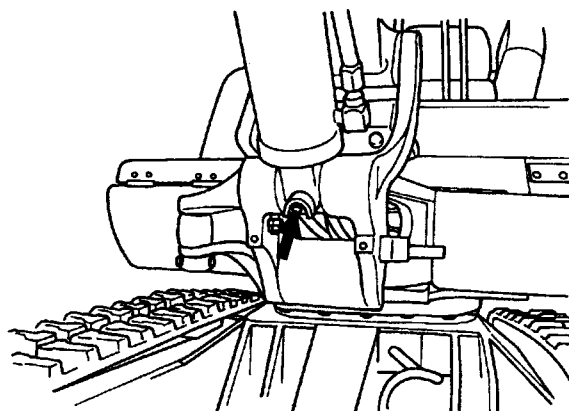

M585-07-004

- (3) Boom foot

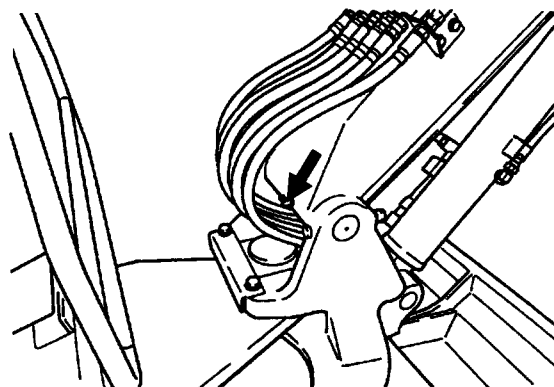

M585-07-005

MAINTENANCE

- (4) Arm cylinder rod side.
Bucket cylinder bottom side.

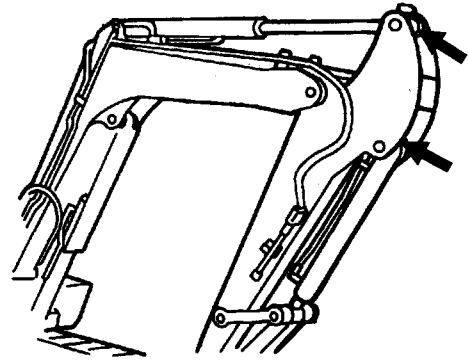

M585-07-006

- (5) Boom and Arm connecting pin.
Arm cylinder bottom side.

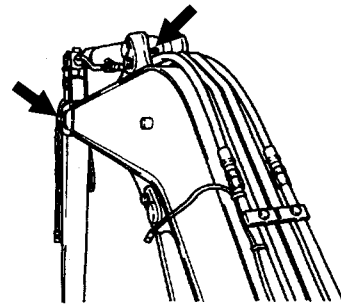

- (6) Swing cylinder.

M571-07-006

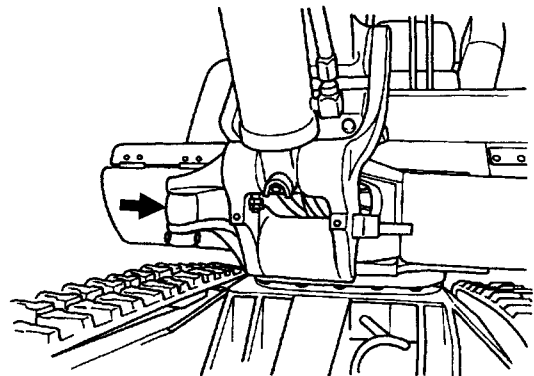

- (7) Swing post.

M585-07-004

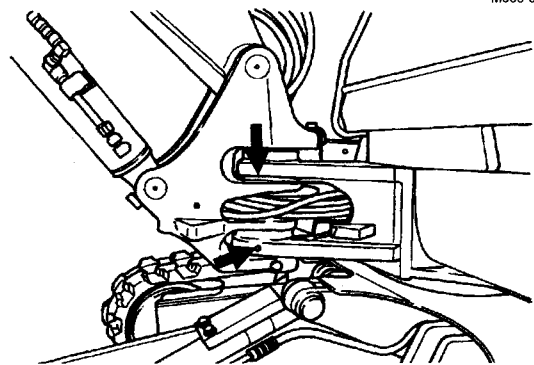

M585-07-048

MAINTENANCE

2

**Bucket Cylinder Rod End
Bucket and link connecting pins**
--- every 50 hours

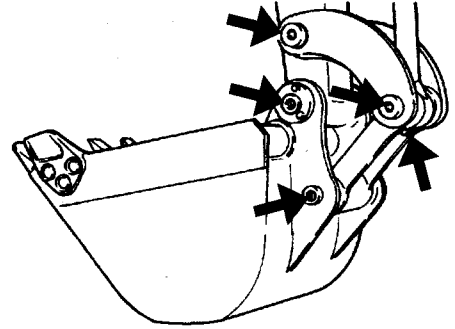

M503-07-092

PRECAUTIONS FOR FRONT ATTACHMENT AND BLADE REMOVAL

- When pins are removed to replace the front attachment or blade, do not attempt to clean the bore insides of the bushings.
- Before installing the front attachment or the blade, apply grease sufficiently to the pin-boss ends or the dust seals of the cylinders.
- Be sure to install at least one shim on both side of front joint pins. (Not required when bucket O-ring is installed.)
- When the swing post is disassembled, apply a film of grease to the pins and the thrust plate before reinstalling them.

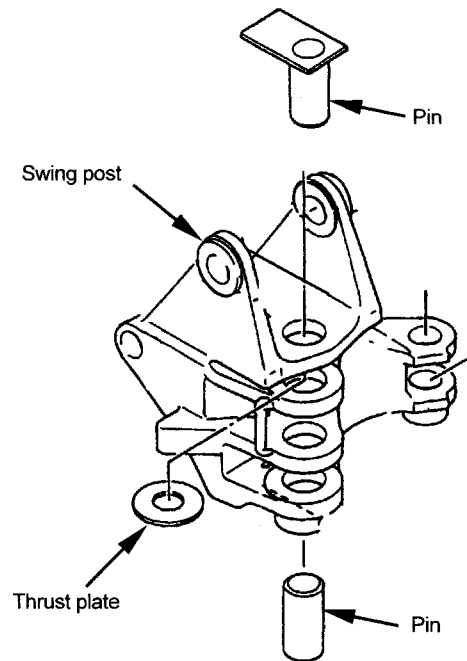

M585-07-035

MAINTENANCE

3

Swing Bearing --- every 500 hours



CAUTION: Lubricating both the swing bearing and gear and rotating the upperstructure must be done by one person. Before you lubricate the swing bearing, clear the area off all persons.

Each time you leave the cab

- Lower the bucket to the ground.
- Stop the engine.
- Pull the pilot control shut-off lever to the LOCK position.

1. Park the machine on a level surface.
2. Lower the bucket and blade to the ground.
3. Run the engine at slow idle speed without load for 5 minutes.
4. Turn the key switch OFF. Remove the key from the key switch.
5. Pull the pilot control shut-off lever to the LOCK position.
6. With the upperstructure stationary, apply grease by 2 or 3 (shots), using a grease gun.
7. Start the engine. Raise the bucket several inches off the ground and rotate the upperstructure 90° (1/4 turn).
8. Lower the bucket to the ground.
9. Repeat the procedure 8 times (2 turns), beginning with step 5.
10. Apply grease to the swing bearing until grease can be seen escaping from the swing bearing seals.
11. Take care not to supply excessive grease.

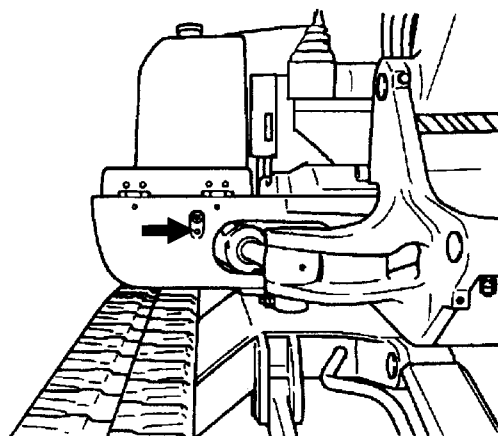

M1LS-07-001

MAINTENANCE

4

Swing Internal Gear --- every 500 hours



CAUTION: Adding or changing swing internal gear grease and rotating the upperstructure must be done by one person. Before you start, clear the area off all persons.

Each time you leave the cab

- Lower the bucket to the ground.
- Stop the engine.
- Pull the pilot control shut-off lever to the LOCK position.

1. Park the machine on a level surface.
2. Lower the bucket and blade to the ground.
3. Run the engine at slow idle speed without load for 5 minutes.
4. Turn the key switch OFF. Remove the key from the key switch.
5. Pull the pilot control shut-off lever to the LOCK position.
6. Remove the cover from the bottom of the under-carriage.
Check if grease inside is cloudy, due to contamination by water or dirt.
7. Apply grease to grease fitting shown in right drawing.
8. In order to apply grease evenly to the swing gear, raise the bucket approximately 200 mm (8in) off the ground, swing the upperstructure four 90° intervals (one full turn) and apply grease at each interval. Total grease amount with 4 times is 0.1 to 0.2 liter

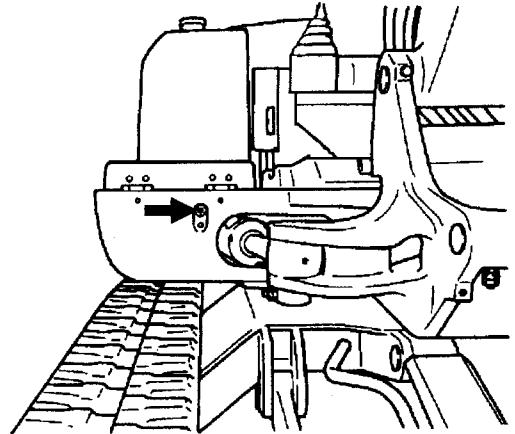

M1LS-07-001

	Grease Capacity
ZAXIS30, 35	3.0 to 3.3 L (3.2 to 3.5 US qt)
ZAXIS40, 50	3.2 to 3.5 L (3.5 to 3.7 US qt)

MAINTENANCE

5

Control Lever Universal Joint --- every 500 hours or yearly

Remove the boot from the pilot valve and apply grease to the four places of the universal joint, as indicated by arrows.

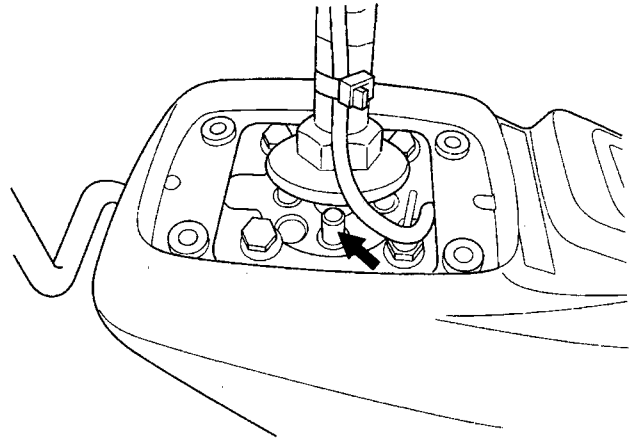

M1LD-07-002

MAINTENANCE

B. ENGINE

1 Engine Oil Level --- check daily

IMPORTANT: For most accurate readings, check the oil level every day before starting the machine. Be sure the machine is on a level surface.

1. Remove dipstick (1). Wipe oil off with a clean cloth. Reinsert dipstick (1).
2. Remove dipstick (1) again. Read level. Oil level must be between the marks.
3. If necessary, add oil via oil filler (2). Be sure to use only recommended oil (see Recommended Engine Oil Chart).

NOTE: Checking the oil level immediately after shut down will result in inaccurate readings. Be sure to allow the oil to settle for at least 10 minutes before checking.

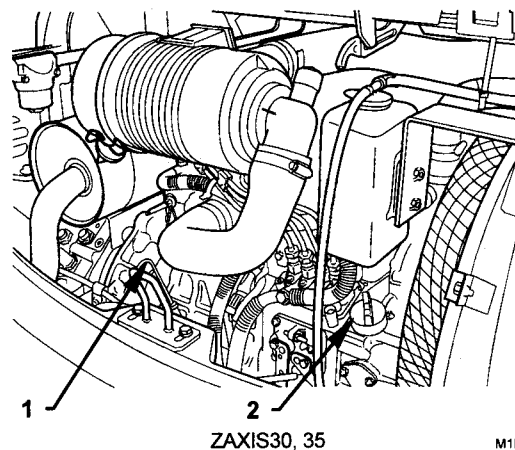

M1LS-07-008

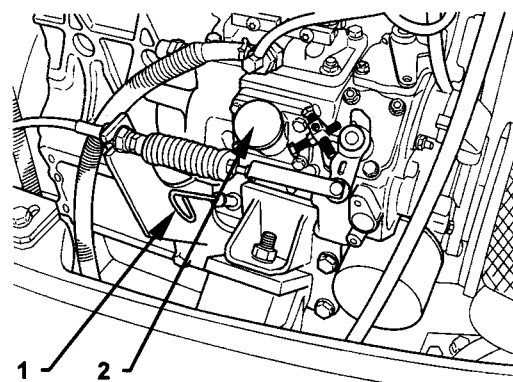

ZAXIS40, 50

M1LS-07-009

MAINTENANCE

2 Change Engine Oil --- every 250 hours

3 Replace Engine Oil Filters --- every 250 hours

1. Run the engine to warm oil.
DO NOT run the engine until oil is hot.
2. Park the machine on a level surface.
3. Lower the bucket and blade to the ground.
4. Run the engine at slow idle speed without load for 5 minutes.
5. Turn the key switch OFF. Remove the key from the key switch.
6. Pull the pilot control shut-off lever to the LOCK position.

CAUTION: Engine oil may be hot. Take extra care to avoid burns.

7. Remove drain plug (2) from oil pan (1). Allow oil to drain through a clean cloth into a 10 liter container.
8. After all oil has drained, inspect cloth for any debris such as small pieces of metal.
9. Install and tighten drain plug (2).

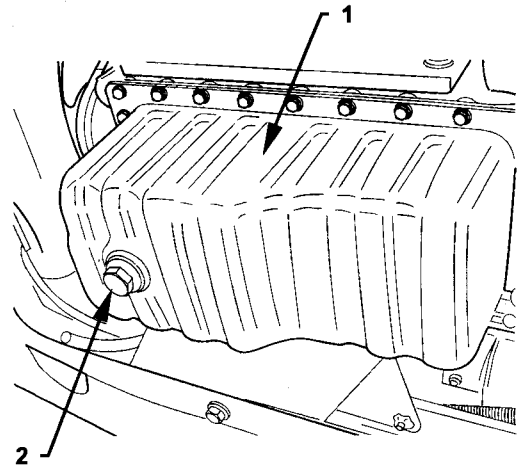

ZAXIS30, 35

M1LS-07-010

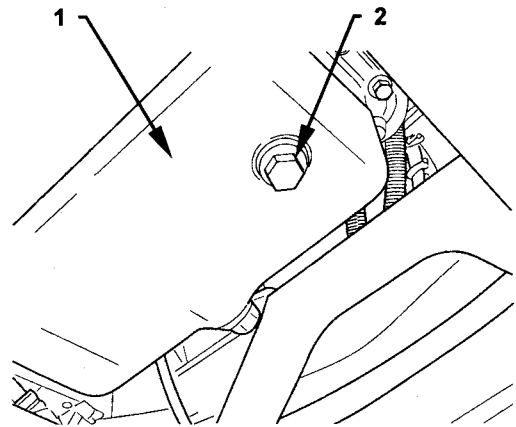

ZAXIS40, 50

IM1LS-07-011

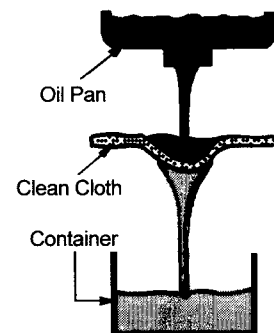

M104-07-010

MAINTENANCE

10. Remove the filter cartridge of engine oil filter (3) by turning it counterclockwise with the filter wrench.
11. Clean the filter gasket contact area on the engine.
12. Apply a thin film of clean oil to the gasket of new filter.
13. Install new filter. Turn the filter cartridge clockwise by hand until the gasket touches the contact area. Be sure not to damage the gasket when installing the filter.
14. Tighten engine oil filter (3) 1-1/4 turn more using the 120filter wrench.
15. Remove filler cap (4). Fill the engine with recommended oil. Check that oil level is between the circle marks on the dipstick after 15 minutes.

ZAXIS30, 35 :	6.2 L (1.6 US gal)
ZAXIS40, 50 :	9.0 L (2.4 US gal)

16. Install filler cap (4).
17. Start the engine. Run the engine at slow idle for 5 minutes.
18. Check that the engine oil pressure indicator on the monitor panel goes out immediately. If not, stop the engine immediately and find the cause.
19. Stop the engine. Remove the key from the key switch.
20. Check for any leakage at the drain plug.
21. Check oil level on dipstick (5).

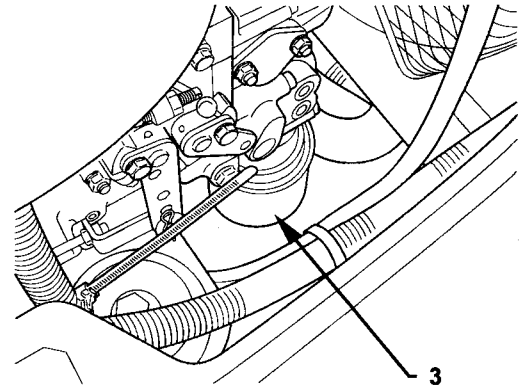

M1LS-07-012

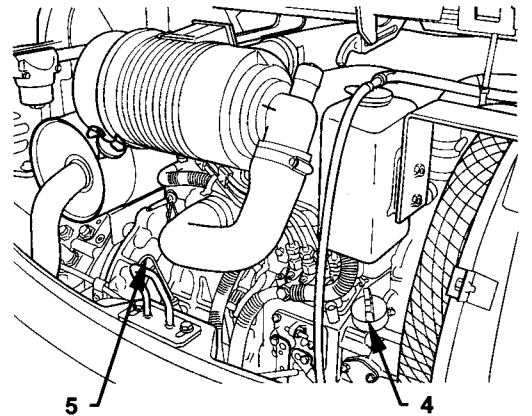

ZAXIS30, 35

M1LS-07-008

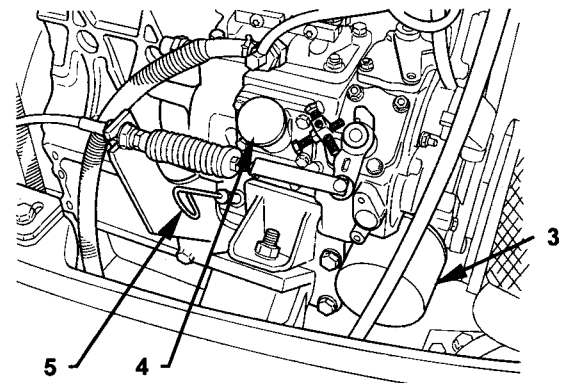

ZAXIS40, 50

IM1LS-07-009

MAINTENANCE

C. TRANSMISSION

Travel Reduction Gear

Check Oil Level --- every 250 hours

1. Park the machine on a level surface.
2. Rotate the travel motor until plugs position is as illustrated on the right.
3. Lower the bucket and blade to the ground.
4. Run the engine at slow idle speed without load for 5 minutes.
5. Stop the engine. Remove the key from the key switch.
6. Pull the pilot control shut-off lever to the LOCK position.

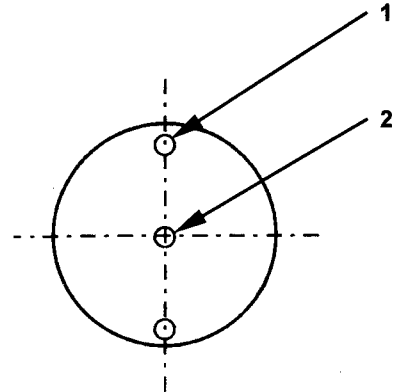

M503-07-015



CAUTION: Keep body and face away from the air release plug. Gear oil is hot. Wait for gear oil to cool and then gradually loosen the air release plug to release pressure.

7. After gear oil has cooled, slowly loosen air release plug (1) to release pressure.
8. Remove oil level check plug (2). Oil must be up to the bottom of hole.
9. If necessary, add oil until oil flows out of the oil level check plug hole. (See gear oil chart)
10. Wrap the plug threads with sealing-type tape. Install the plug.
Tighten the plug to 29 to 39 N·m (3 to 4 kgf·m, 21.5 to 29 lbf·ft).
11. Check the gear oil level in the other travel reduction gear.

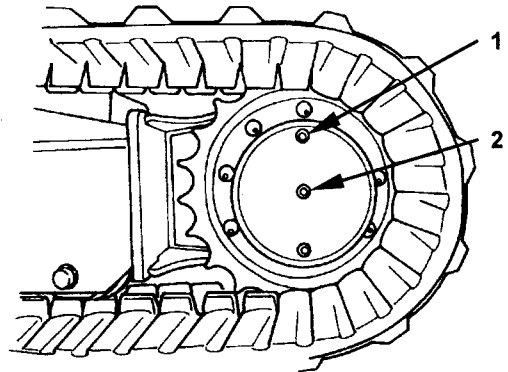

M585-07-080

MAINTENANCE

Change Gear Oil --- every 1000 hours

1. Park the machine on a level surface.
2. Rotate the travel motor until plugs position is as illustrated on the right.
3. Lower the bucket and blade to the ground.
4. Run the engine at slow idle speed without load for 5 minutes.
5. Stop the engine. Remove the key from the key switch.
6. Pull the pilot control shut-off lever to the LOCK position.

⚠ CAUTION: Keep body and face away from the air release plug. Gear oil is hot. Wait for gear oil to cool and then gradually loosen the air release plug to release pressure.

7. After gear oil has cooled, slowly loosen plug (1),(3) to release pressure.
8. Remove plug (2),(5) to drain oil.
9. Wrap the threads of the drain plugs with sealing-type tape. Install the plug (2) and (5). Tighten the plug (2),(5) to 29 to 39 N·m (3 to 4 kgf·m, 21.5 to 29 lbf·ft).
10. Remove oil level check plug (1) and (4).
11. Add oil until oil flows out of the plug (1) and (4) holes. (See gear oil chart)
12. Wrap the threads of plug (1),(3) and (4) with sealing-type tape. Reinstall the plugs. Tighten the plugs to 29 to 39 N·m (3 to 4 kgf·m, 21.5 to 29 lbf·ft).
13. Repeat steps 8 to 12 for the other travel reduction gear.

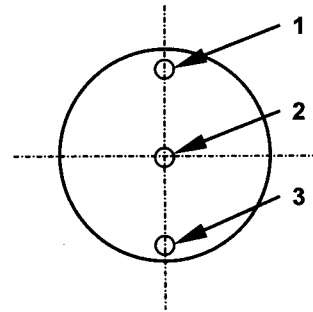

M503-07-015

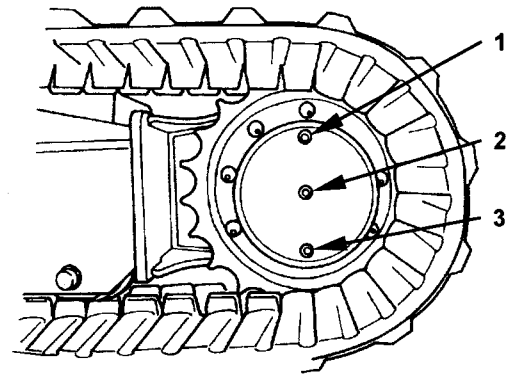

M585-07-080

MAINTENANCE

D. HYDRAULIC SYSTEM

INSPECTION AND MAINTENANCE OF HYDRAULIC EQUIPMENT



CAUTION: During operation the parts of the hydraulic system become very hot. Allow the machine to cool down before beginning inspection or maintenance.

1. Be sure that the machine is parked on a level, solid surface before servicing hydraulic equipment.
2. Lower the bucket and blade to the ground and stop the engine.
3. Begin servicing hydraulic components only after components, hydraulic oil and lubricants are completely cooled, and after releasing residual pressure.
 - a. Bleed air from the hydraulic oil tank to release internal pressure.
 - b. Allow the machine to cool down.
Note that servicing heated and pressurized hydraulic components may cause hot parts and/or oil to fly off or escape suddenly, possibly resulting in personal injury.
 - c. Keep body parts and face away from plugs or screws when removing them.
Hydraulic components may be pressurized even when cooled.
 - d. Never attempt to service or inspect the travel and swing motor circuits on slopes. They are highly pressurized due to selfweight.
4. When connecting hydraulic hoses and pipes, take special care to keep seal surfaces free from dirt and to avoid damaging them. Keep these precautions in mind:
 - a. Wash hoses, pipes, and the tank interior with a washing liquid and thoroughly wipe it out before reconnecting them.
 - b. Only use O-rings that are free of damage or defects. Be careful not to damage them during reassembly.
 - c. Do not allow high pressure hoses to twist when connecting them. The life of twisted hoses will be shortened considerably.
 - d. Carefully tighten low pressure hose clamps.
5. When adding hydraulic oil, always use the same brand of oil; do not mix brands of oil. As the machine is filled with New Landy HN when it is shipped from the factory, use it as a general rule. When selecting to use another brand of oil listed in the table "Brand names of recommended hydraulic oil", be sure to completely replace the oil in the system.
6. Do not use hydraulic oils other than those listed in the table "Brand names of recommended hydraulic oil".
7. Never run the engine without oil in the hydraulic oil tank.

MAINTENANCE

1 Check Hydraulic Oil Level --- daily

IMPORTANT: Never run the engine without oil in hydraulic oil tank.

1. Park the machine on a level surface.
2. Position the machine with the arm cylinder fully retracted and the bucket cylinder fully extended.
3. Lower the bucket and blade to the ground.
4. Run the engine at slow idle speed without load for 5 minutes.
5. Turn the key switch OFF. Remove the key from the key switch.
6. Pull the pilot control shut-off lever to the LOCK position.
7. Check oil level gauge (1) on the hydraulic oil tank. Oil must be between marks on the gauge. If necessary, add oil.

CAUTION: Keep body and face away from the cap or plug. Turn cap slowly and remove the cap only after releasing the internal pressure completely.

8. Turn cap (2) slowly to release the air.
9. Turn cap further and remove cap or plug.
10. Add oil. Recheck oil level gauge (1).
11. Install cap.

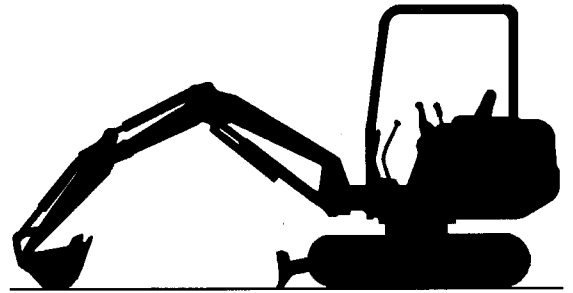

SA-675

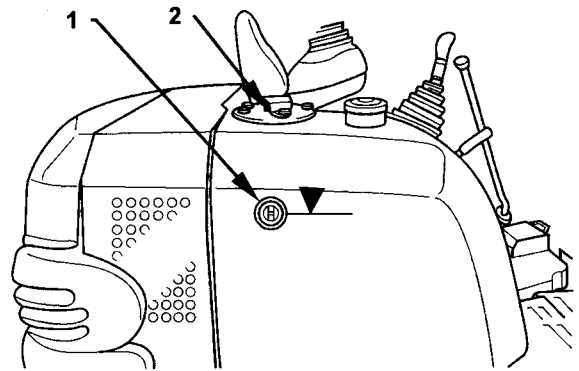

M1LS-07-002

MAINTENANCE

2

Drain Hydraulic Tank Sump --- every 250 hours

IMPORTANT: Never run the engine without oil in hydraulic oil tank.

1. Park the machine on a level surface.
2. Lower the bucket and blade to the ground.
3. Run the engine at slow idle speed without load for 5 minutes.
4. Turn the key switch OFF. Remove the key from the key switch.
5. Pull the pilot control shut-off lever to the LOCK position.

CAUTION: Keep body and face away from the cap or plug. Turn cap slowly and remove the cap only after releasing the internal pressure completely.

6. Turn the cap slowly to release the air.

CAUTION: Do not loosen the drain plug until oil is cool. Hydraulic oil may be hot, potentially causing serious injury.

7. After oil is cool, loosen drain plug (1) to drain water and sediment. Do not remove the plug completely, only loosen it enough to drain water and sediment.
8. After draining water and sediment, retighten the plug (1).

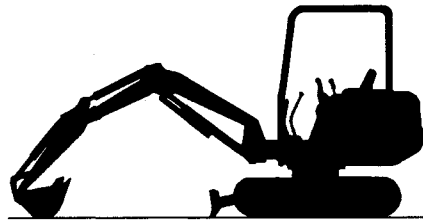

SA-675

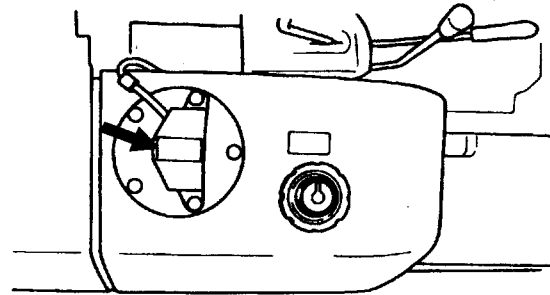

M585-07-024

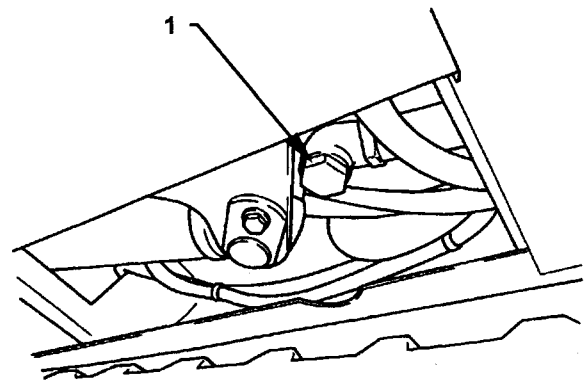

ZAXIS30, 35

M585-07-023

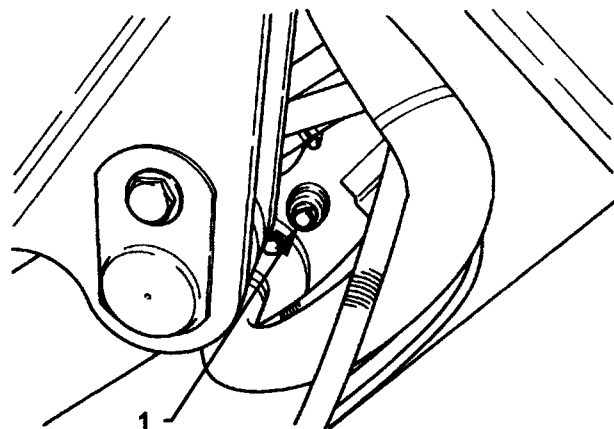

ZAXIS40, 50

M585-07-070

MAINTENANCE

3 Change Hydraulic Oil

4 Clean Suction Filter

--- every 2000 hours

IMPORTANT: Hydraulic oil changing intervals differ according to kind of hydraulic oil used. See recommended oil chart.

CAUTION: Hydraulic oil may be hot. Wait for oil to cool before starting work.

1. Park the machine on a level surface.
2. Position the machine with the arm cylinder fully retracted and the bucket cylinder fully extended.
3. Lower the bucket and blade to the ground.
4. Run the engine at slow idle speed without load for 5 minutes.
5. Stop the engine. Remove the key from the key switch.
6. Pull the pilot control shut-off lever to the LOCK position.
7. Open the cover
8. Clean the top of the hydraulic oil tank to keep dirt out of the hydraulic system.

CAUTION: The hydraulic oil tank is pressurized. Slowly loose cap (1) to release pressure.

9. Slowly loosen cap (1) to release pressure.
10. Remove cap (1).
11. Drain oil using a suction pump. The hydraulic oil tank capacity, up to specified oil level, is approximately :

ZAXIS30, 35 :	50 L (13.2 US gal)
ZAXIS40, 50 :	84 L (22.2 US gal)



SA-675

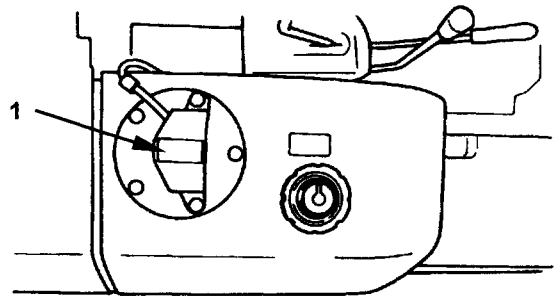

M585-07-024

MAINTENANCE

12. Remove drain plug (2). Allow oil to drain.
13. Remove suction filter (3) with cover (4).
14. Clean suction filter (3) and tank interior.
15. Install suction filter (3) with cover (4).
16. Install six bolts and tighten them to 49 N·m (5 kgf·m, 36 lbf·ft)
17. Clean, install and tighten drain plug (2).
18. Add oil until it is between the marks on oil level gauge.

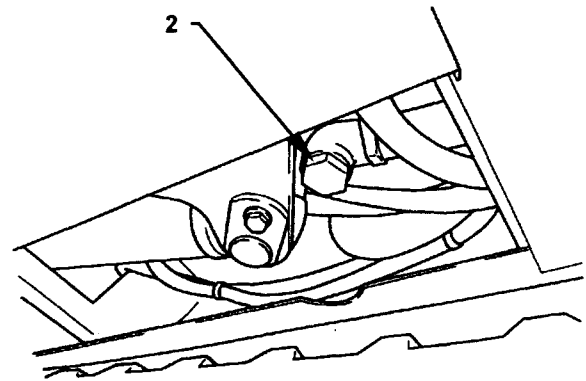

ZAXIS30, 35

M585-07-023

IMPORTANT: If the hydraulic pump is not filled with oil, it will be damaged when the engine is started.

Bleed air from the hydraulic pump.
(Refer to Bleed Air from the hydraulic system.)

Check the hydraulic oil tank gauge, add oil if necessary.

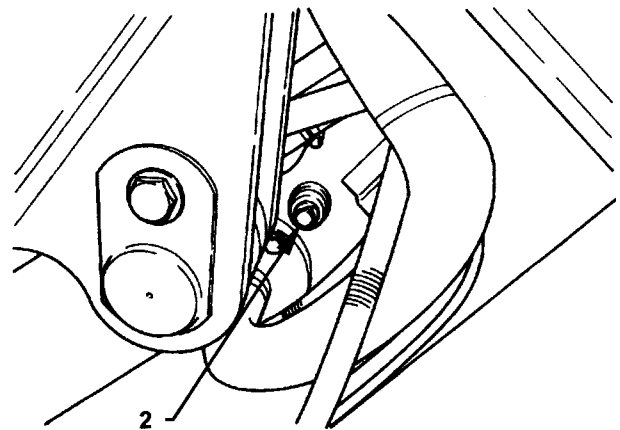

ZAXIS40, 50

M585-07-070

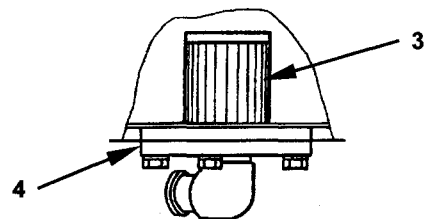

M503-07-027

MAINTENANCE

Bleed Air from the Hydraulic System

After changing hydraulic oil, be sure to bleed air from the hydraulic system as follows:

1. Bleed air from the pump

IMPORTANT: The pump will be damaged if the engine is started without hydraulic oil in the pump. Be sure to bleed air.

- (1) Connect all hydraulic lines to the hydraulic pump. Fill any hydraulic components, that can be filled with hydraulic oil, with hydraulic oil as much as possible.
- (2) Add hydraulic oil to the hydraulic oil tank to the specified level.
- (3) Check all line connections for any oil leaks. Set the engine speed control lever in the slow idle position.
- (4) Start the engine. Wait 5 to 10 seconds. Stop the engine.
- (5) Check the hydraulic oil level at the level gauge. Add hydraulic oil if necessary.
- (6) Start and run the engine for approximately 1 minute. Confirm that hydraulic oil in the hydraulic oil tank is sufficient.
- (7) This is the end of the hydraulic pump air bleeding.

 **NOTE:** If the hydraulic pump is left empty overnight or longer, be sure to fill the pump with clean hydraulic oil before performing the air bleeding procedure above.

2. Bleed each hydraulic circuit

- (1) Run the engine at slow idle and evenly operate each cylinder and swing motor repeatedly for 15 minutes to bleed air from hydraulic system.
- (2) Position the machine in the hydraulic oil level checking position, as illustrated on page 7-25. Stop the engine.
- (3) Check hydraulic oil level. Add oil if necessary.

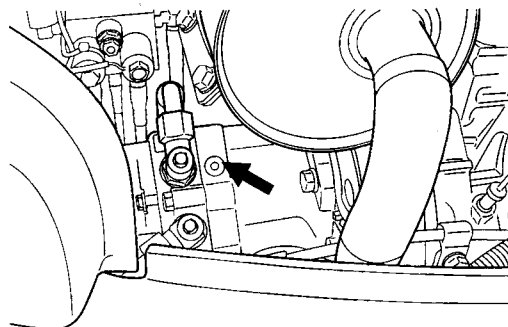

ZAXIS30, 35

M1LS-07-013

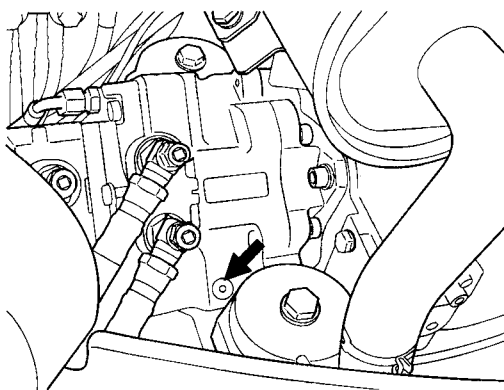

ZAXIS40, 50

M1LS-00-004

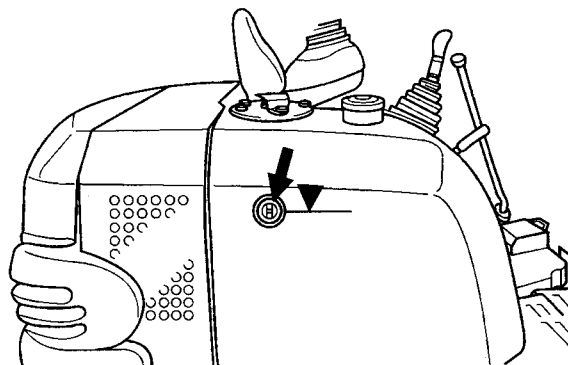

M1LS-07-002

MAINTENANCE

INCREASE AIR PRESSURE IN HYDRAULIC OIL TANK

After replacing hydraulic oil in the hydraulic oil tank, please follow below procedure:

1. Fully extend each of the boom, arm and bucket cylinders as illustrated.
2. With each cylinder extended fully, remove the oil supply plug once. Then, reinstall the oil supply plug.
3. Operate the machine normally. Thus, air pressure in the hydraulic oil tank will increase due to this operation.



M585-07-083

MAINTENANCE

5

Replace Hydraulic Oil Tank Filter --- every 500 hours

1. Park the machine on a level surface.
2. Lower the bucket and blade to the ground.
3. Run the engine at slow idle speed without load for 5 minutes.
4. Stop the engine. Remove the key from the key switch.
5. Pull the pilot control shut-off lever to the LOCK position.



CAUTION: The hydraulic oil tank is pressurized. Slowly loosen the cap to release the pressure.

6. Slowly loosen the cap to release the pressure, then remove the cap.
7. Remove five bolts (1), cover (2) and O-ring (3).
8. Pull rod (4) up to remove element (5) assembly.

 **NOTE:** Remove the element and inspect for metal particles and debris in the bottom of the filter can. Excessive amounts of brass and steel particles can indicate a failed hydraulic pump, motor, valve or an impending failure. A rubber type of material can indicate cylinder packing failure.

9. Replace O-ring (3) and element (5) with new ones.
10. Install rod (4) and element (5) assembly. Be sure to insert element (5) securely into pipe assembly (6).
11. Reinstall cover (2), aligning support (7) of cover (2) with rod (4).
12. Install and tighten bolts (1) to 50 N·m (5 kgf·m, 36 lbt·ft).

IMPORTANT: If the hydraulic pump is not filled with oil, it will be damaged when the engine is started.

**Purge air from the hydraulic pump.
(Refer to Bleed Air from the hydraulic system.)**

Check the hydraulic oil tank gauge add oil if necessary.

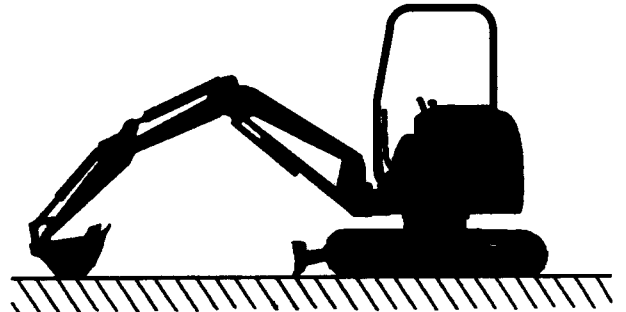

M586-05-030

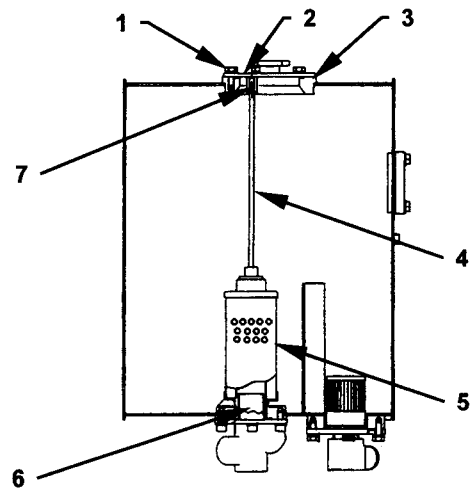

M588-07-066

MAINTENANCE

6

Replace Pilot Oil Filter --- every 1000 hours

1. Park the machine on a level surface.
2. Lower the bucket and blade to the ground.
3. Run the engine at slow idle speed without load for 5 minutes.
4. Stop the engine. Remove the key from the key switch.
5. Operate the right and left control levers to release pressure from the pilot accumulator.
6. Pull the pilot control shut-off lever to the LOCK position.



CAUTION: Keep body and face away from the cap or plug. Turn cap slowly and remove the cap only after releasing the internal pressure completely.

7. Rotate the hexagon on filter case (2) counterclockwise using a tool such as a wrench to remove filter case (2) from filter head (1).
8. While rotating filter element (3), pull to remove filter element (3) downward.
9. Replace O-ring (4) with a new one.
10. Completely seat O-ring (4) into the O-ring groove on filter head (1).
11. Coat the seal on new filter element (3) with clean hydraulic oil. Completely install filter element (3) into filter head (1) while rotating filter element (3) taking care not to damage the filter element.
12. Take care so that dust and/or water never enter into the filter case.
13. Install filter case (2) into filter head (1) while rotating clockwise.
Tightening Torque: 25 to 34 N·m (2.5 to 3.5 kgf·m),
18.0 to 25.5 lbf·ft)
14. After replacing the filter element, bleed any remaining air from the hydraulic circuit while running the engine at a slow speed for approx. 5 minutes.
15. Check the oil level in the hydraulic oil tank. Refill with hydraulic oil as necessary.

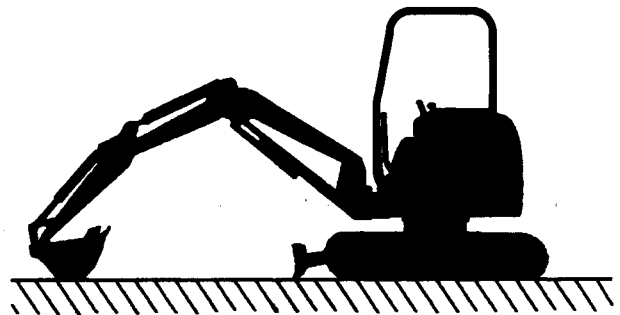

Pilot Oil Filter

M586-05-030

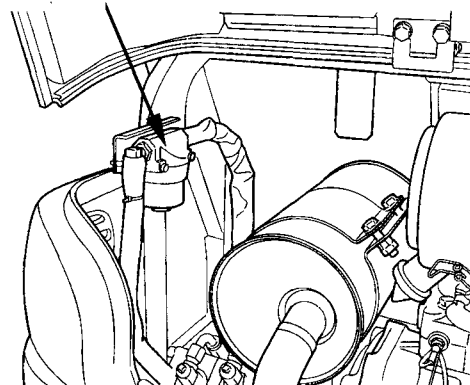

ZAXIS30, 35

M1LS-07-004

Pilot Oil Filter

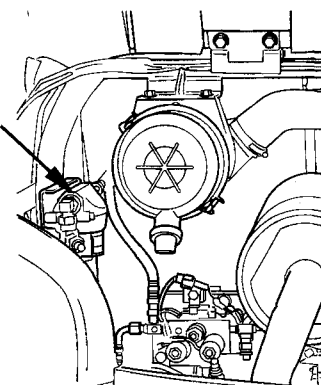

ZAXIS40, 50

M1LS-07-014

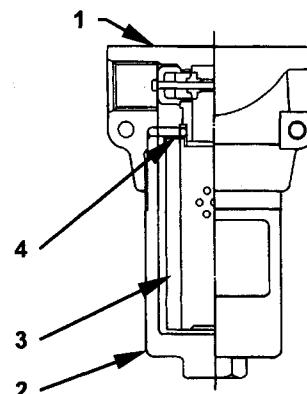

M503-07-031

MAINTENANCE

7

Check Hoses and Lines

- daily
- every 250 hours

CAUTION: Escaping fluid under pressure can penetrate the skin causing serious injury. To avoid this hazard, search for leaks with a piece of cardboard. Take care to protect hands and body from high-pressure fluids. If an accident occurs, see a doctor familiar with this type of injury immediately. Any fluid injected into the skin must be surgically removed within a few hours or gangrene may result.

- CAUTION:** Hydraulic oil and lubricant leaks can lead to fire that may result in serious injury. To avoid this hazard :
- Park the machine on a firm, level surface. Lower the bucket to the ground. Stop the engine. Remove key from the key switch. Pull the pilot control shut-off lever to the LOCK position.
 - Check for missing or loose clamps, kinked hoses, lines or hoses that rub against each other, damaged oil cooler, and loose oil cooler flange bolts, for leaks. Check hoses, lines and oil cooler at the check points indicated below for leaks and other damage that may result in future leaks. If any abnormalities are found, replace or retighten them, as shown in Tables 1-3.
 - Tighten, repair or replace any missing, loose or damaged clamps, hoses, lines, oil cooler, and loose oil cooler flange bolts. Do not bend or strike high-pressure lines. Never install bent or damaged hoses or lines.

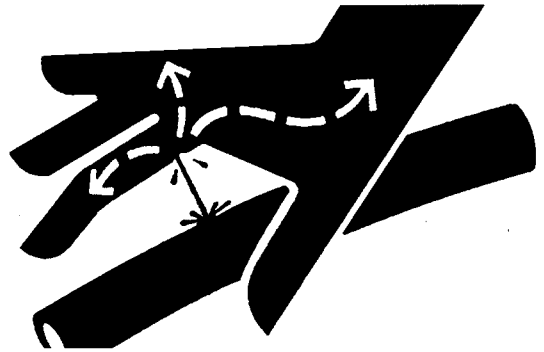

SA-031

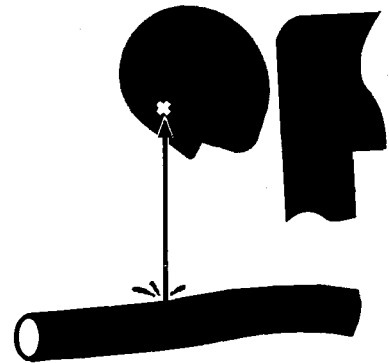

SA-292

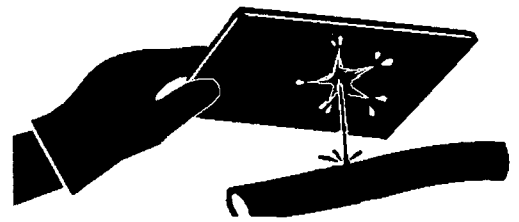

SA-044

MAINTENANCE

Table 1. Hoses

Interval(hours)	Check Points	Abnormalities	Remedies
Daily	Hose covers	Leak (1)	Replace
	Hose ends	Leak (2)	Replace
	Fittings	Leak (3)	Retighten or replace hose or O-ring
Every 250 hours	Hose covers	Crack (4)	Replace
	Hose ends	Crack (5)	Replace
	Hose covers	Exposed reinforcement (6)	Replace
	Hose covers	Blister (7)	Replace
	Hose	Bend (8)	Replace
Hose	Collapse (9)	Replace (Use proper bend radius)	
Hose ends and fittings	Deformation or Corrosion (10)	Replace	

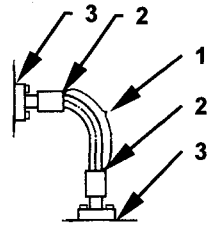

M137-07-008

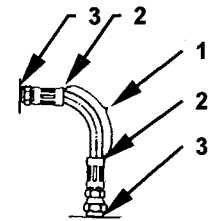

M115-07-145

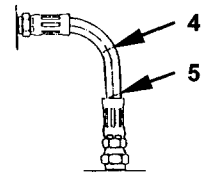

M115-07-146

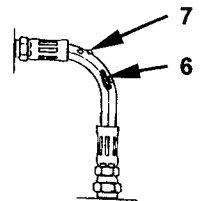

M115-07-147

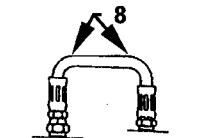

M115-07-148

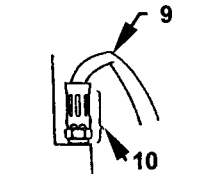

M115-07-149

NOTE: Refer to the illustrations in Fig.1 for each check point location or for a description of the abnormality. Use genuine Hitachi parts.

Fig.1

MAINTENANCE

Table 2. Lines

Interval(hours)	Check Points	Abnormalities	Remedies
Daily	Contact surfaces of flange joints	Leak (11)	Replace O-ring and/or retighten bolts
	Welded surfaces on joints	Leak (12)	Replace
Every 250 hours	Joint neck	Crack (13)	Replace
	Welded surfaces on joints	Crack (12)	Replace
	Clamps	Missing Deformation Loose	Replace Replace Retighten

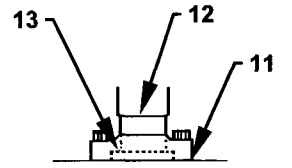

M137-07-001

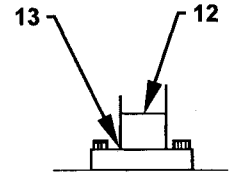

M137-07-007

Fig.2

NOTE: Refer to the illustrations in Fig.2 for each check point location or for a description of the abnormality. Use genuine Hitachi parts.

Table 3. Oil cooler

Interval(hours)	Check Points	Abnormalities	Remedies
Every 250 hours	Contact surfaces of flange joints	Leak (14)	Replace O-ring and/or retighten bolts
	Oil cooler	Leak (15)	Replace

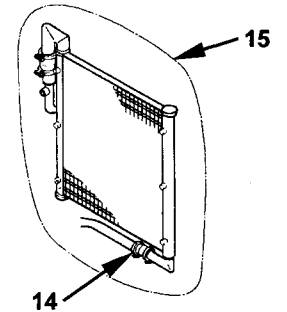

M155-07-049

Fig.3

NOTE: Refer to the illustrations in Fig.3 for each check point location .

MAINTENANCE

Metal Face Seal Fittings

Fittings are used on smaller hoses and consist of a metal flare and a metal flare seat.

- a. Inspect flare (5) and flare seat (4). They must be free of dirt or obvious defects.

IMPORTANT: Defects in the tube flare cannot be repaired. Overtightening a defective flare fitting will not stop a leak.

- b. Tighten fitting (1) by hand.
- c. Tighten fitting (1) or nut (3) to the torque values shown. Do not allow hose (2) to twist when tightening fittings.

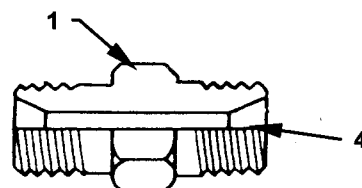

M555-07-010

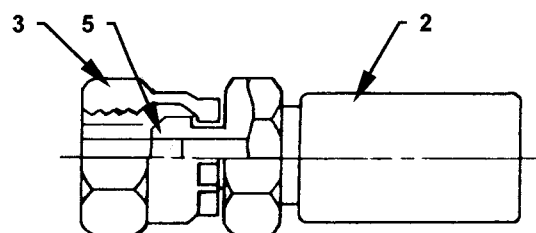

M555-07-011

Width across flats (mm)		19	22	27
Fastening torque	N·m	29.5	39	64
	(kgf·m)	(3)	(4)	(6.5)
	(lbf·ft)	(21.5)	(29)	(47)

MAINTENANCE

Quick Coupler

1. Connecting Coupler

Always grasp the coupler by its clamp section. Push the body straight until the dust prevention cover retracts approx. 2 mm. Then, pull the clamp section straight to make sure that the coupler is properly connected and will not disconnect.

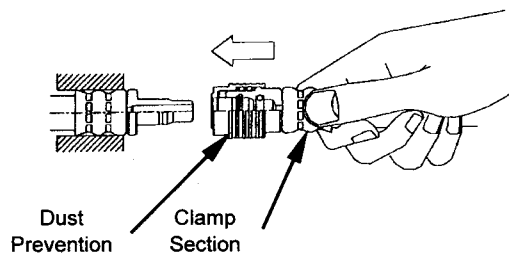

M1LA-07-014

NOTE: If the coupler is grasped and pushed by the dust prevention cover, or not pushed until the dust prevention cover retracts, incomplete connection of the coupler may result, causing the coupler to disconnect when oil pressure increases. Even if the coupler is incompletely connected, if pulling force is diagonally applied, the coupler may be difficult to disconnect. However, the coupler may be easily disconnected in this case when oil pressure increases. Take care not to diagonally push the coupler. Failure to do so damage to the inner parts, cause oil leak, and/or unexpected coupler disconnection may result.

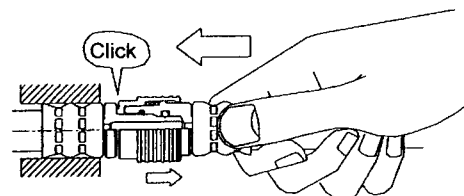

M1LA-07-015

2. Disconnecting Coupler

Be sure to disconnect the coupler only after removing any foreign matter adhered such as soil adhered to the joint with cleaning oil.

- While grasping the clamp section, push the body straight approx. 2 mm.

Approximately 2 mm

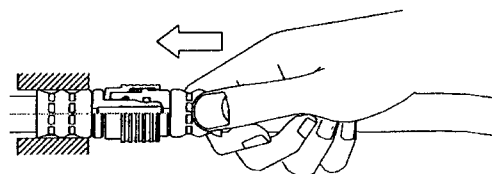

M1LA-07-016

- While pushing the body, pull the dust prevention cover.

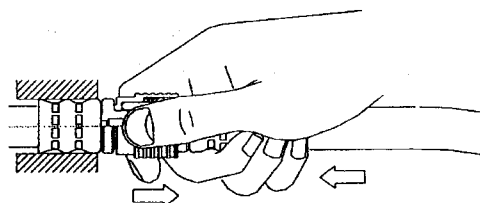

M1LA-07-017

- Pull the overall coupler together along with the dust prevention cover to disconnect the coupler.

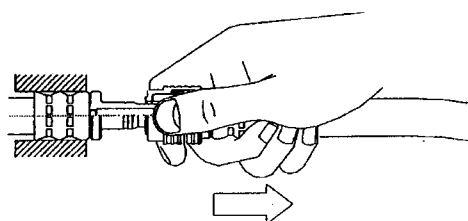

M1LA-07-018

MAINTENANCE

NOTE: When disconnecting a coupler located in a narrow space that is difficult for your hand to enter, use a screwdriver following the procedures as described below.

Using Screwdriver

A screwdriver with a tip thickness of less than 1 mm and a tip width of approx. 5 mm is appropriate to this work.

- Slightly push the hose toward the coupler approx. 2 mm.
- While pushing the hose toward the coupler, insert a screwdriver in the position as illustrated to the right. Twist the screwdriver about 90°. After making the gap between the adapter and the dust prevention cover more than 2mm, pull the hose to disconnect the coupler.

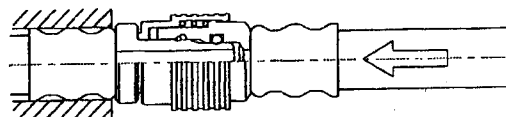

M1LA-07-021

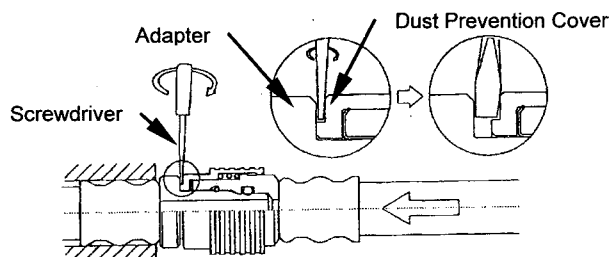

M1LA-07-022

3. Precautions for Re-using Coupler

- Before connecting the coupler, be sure to check the coupler surface for any adhered foreign matter. Clean to remove the foreign matter if any. Adhered foreign matter may cause oil leaks and/or disconnection of the coupler.
- When a hose clamping is required, put a clamp 200 mm away from the joint edge. If the hose is clamped as illustrated to the right, the coupler joint may slide as oil pressure changes, causing oil leaks due to the premature inner parts wear.
- Don't use the coupler as a foot step and don't handle the coupler roughly. If the dust prevention cover is broken, the coupler may become difficult to disconnect.
- Don't paint on the joint surface. The body will be seized with the dust prevention cover so that the coupler cannot be disconnected.

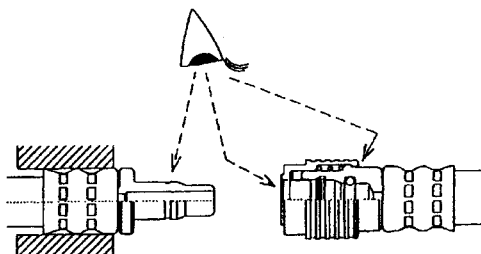

M1LA-07-019

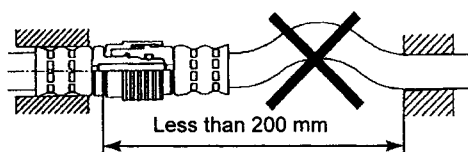

M1LA-07-020

MAINTENANCE

E. FUEL SYSTEM

Recommended Fuel

Use high quality DIESEL FUEL only (JIS K-2204) (ASTM 2-D). Kerosene must NOT be used.

Refueling

1. Park the machine on a level surface.
2. Lower the bucket and blade to the ground.
3. Run the engine at slow idle speed without load for 5 minutes.
4. Stop the engine. Remove the key from the key switch.
5. Pull the pilot control shut-off lever to the LOCK position.



CAUTION: Handle fuel carefully. Shut the engine off before fueling. Do not smoke while you fill the fuel tank or work on fuel system.

6. Check fuel gauge (1) of the monitor panel and fuel gauge (2) of the fuel tank. Add fuel necessary.

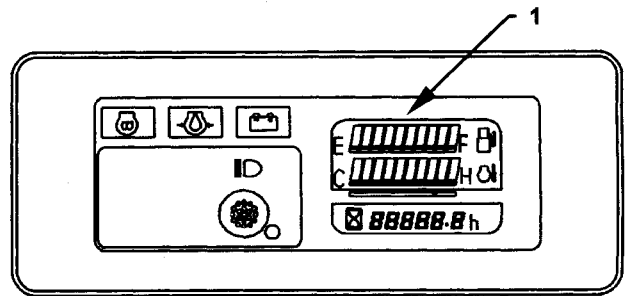

M586-01-014

IMPORTANT: Keep all dirt, dust, water and other foreign materials out of the fuel system.

7. To avoid condensation, fill the tank at the end of each day's operation. Take care not to spill fuel on the machine or ground.

Fuel Tank Capacity: ZAXIS30, 35: 50 L (13.2 US gal)
ZAXIS40, 50: 55 L (14.5 US gal)

8. Tighten fill cap (2) immediately after fueling.

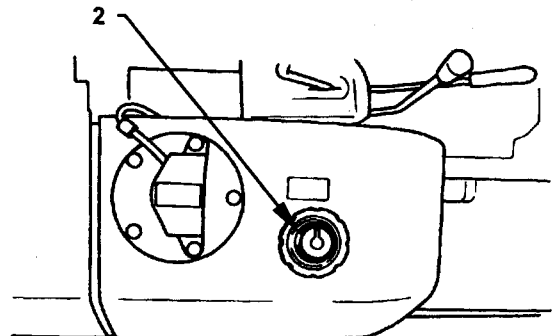

MAINTENANCE

Bleed Air from the Fuel System

IMPORTANT: Air in the fuel system will cause the engine to start hard and/or run roughly. Be sure to bleed air from the system after replacing the fuel filter or draining the tank.

Bleeding Procedure (Automatic Bleeding Device):

1. Confirm that the fuel level is more than one-half of the tank capacity. If the fuel level is lower, automatic bleeding cannot be done. Add fuel.
2. Turn the key switch ON and hold for 10 to 15 seconds to engage automatic bleeding.
3. Start the engine and check for fuel leakage.

1 Drain Fuel Tank Sump --- daily

1. Park the machine on a level surface.
2. Lower the bucket and blade to the ground.
3. Run the engine at slow idle speed without load for 5 minutes.
4. Turn the key switch OFF. Remove the key from the key switch.
5. Pull the pilot control shut-off lever to the LOCK position.
6. Open drain cock (1) for several seconds to drain water and sediment. Close the drain cock.

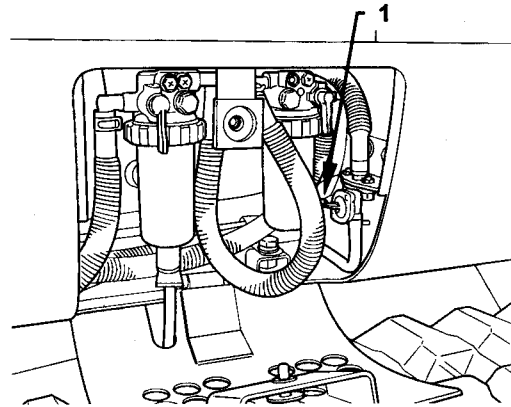

ZAXIS30, 35

M1LS-07-015

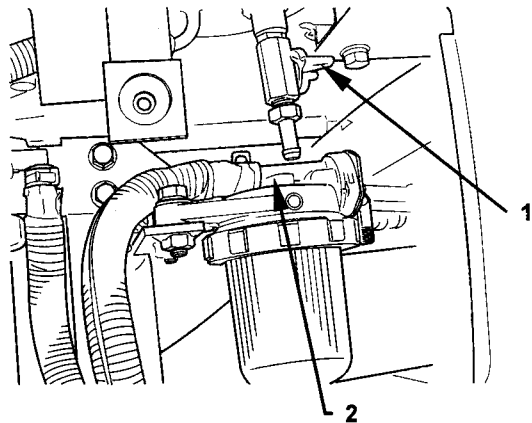

ZAXIS40, 50

M1LS-07-016

2 Check Water Separator --- daily

1. When water is seen collected in transparent filter cup (2).
2. Loosen drain plug (3) to drain water and sediment. Close the drain plug (3).

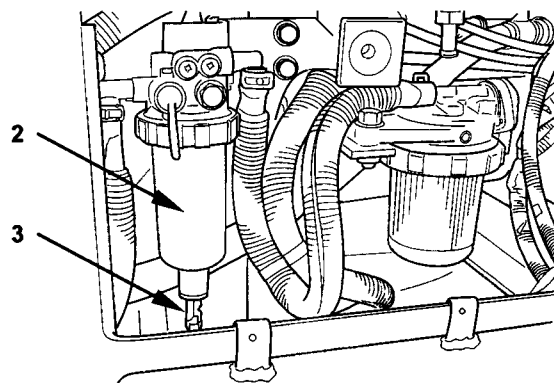

M1LS-07-017

MAINTENANCE

3

Replace Fuel Filter

--- every 500 hours

IMPORTANT: For safety and to protect the environment, always use proper containers when draining fuel. Do not pour fuel onto the ground, down a drain or into a stream, pond or lake. Dispose of waste fuel properly.

1. Close cock (1).
2. Remove ring nut (3) and filter cap (4).
3. Clean filter cap (4).
4. Install new filter element (2), filter cap (4) and ring nut (3).
5. Open cock (1)
6. Loosen plug (5) to bleed air.
7. Tighten plug (5) when fuel flows from the plug hole.
8. Turn the key switch ON and hold for 10 to 15 seconds to engage automatic bleeding.
9. Start the engine and check for fuel leakage.

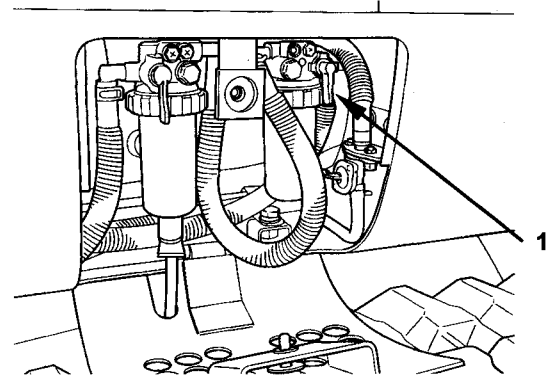

ZAXIS30, 35

M1LS-07-015

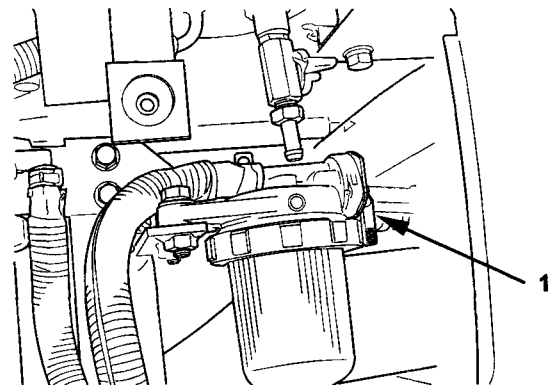

ZAXIS40, 50

M1LS-07-016

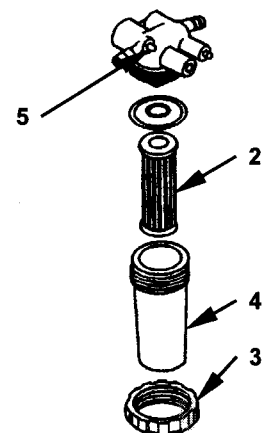

M503-07-038

MAINTENANCE

4

Check Fuel Hoses

- daily
- every 250 hours

CAUTION: Fuel leaks can lead to fires that may result in serious injury.
To avoid this hazard :

- Park the machine on a firm, level surface. Lower the bucket to the ground. Stop the engine. Remove key from the key switch. Pull the pilot control shut-off lever to the LOCK position.
- Check for kinked hoses, and hoses that rub against each other parts for leaks. Check hoses at the check points indicated below for leaks and other damage that may result in future leaks. If any abnormalities are found, replace or retighten them, as shown in Table 4.
- Repair or replace any loose or damaged hoses. Never install bent or damaged hoses.

Table 4. Hoses

Interval(hours)	Check Points	Abnormalities	Remedies
Daily	Hose ends	Leak (1)	Retighten or replace
	Soutache braid hose	Friction (2) Crack (2)	Replace Replace
Every 250 hours	Soutache braid hose	Crack (3)	Replace
	Hose ends	Crack (4)	Replace
	Hose	Bend (5)	Replace
	Hose	Collapse (6)	Replace (Use proper bend radius)
	Hose ends and fittings	Deformation or Corrosion (7)	Replace

NOTE: Refer to the illustrations in Fig.1 for each check point location or for a description of the abnormality. Use genuine Hitachi parts.

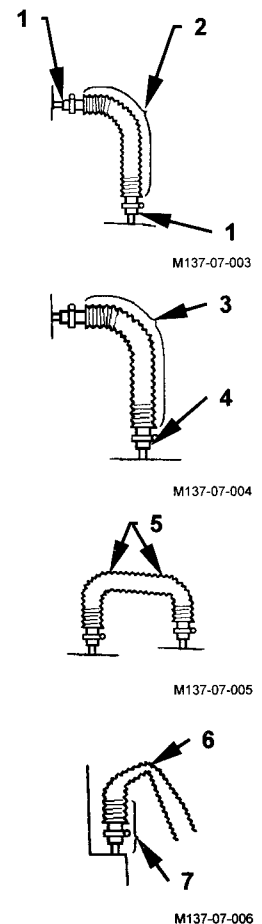

Fig.1

MAINTENANCE

F. AIR CLEANER

1

Clean the Air Cleaner Element

--- every 250 hours or when the air cleaner element are clogged (indicator 4 turns red).

Replace the Air Cleaner Elements

--- after cleaning eight times or after one year

1. Park the machine on a level surface.
2. Lower the bucket and blade to the ground.
3. Run the engine at slow idle speed without load for 5 minutes.
4. Stop the engine. Remove the key from the key switch.
5. Pull the pilot control shut-off lever to the LOCK position.
6. Loosen clamps (2) to remove cover (3).
7. Remove element (1).
8. Tap element (1) with the palm of your hand, NOT ON A HARD SURFACE.



CAUTION: Use reduced compressed air pressure. Clear area of bystanders, guard against flying chips, and wear personal protection equipment including goggles or safety glasses.

9. Clean element (1) using compressed air. Direct the air to the inside of the filter element, blowing out.
10. Clean the filter interior before installing element (1).
11. Install element (1).
12. Install cover (3) and tighten clamps (2).

 **NOTE:** Be sure to align cover (3) and the air cleaner housing with valve (5) downward when installing.

13. Start the engine and run at slow idle.
14. Check the air filter indicator (4). If air filter indicator (4) turns Red. Stop the engine and replace element (1).

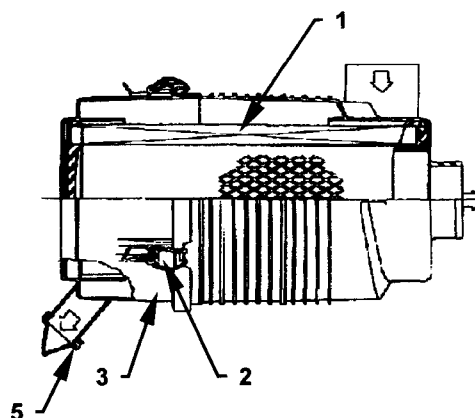

M555-07-023

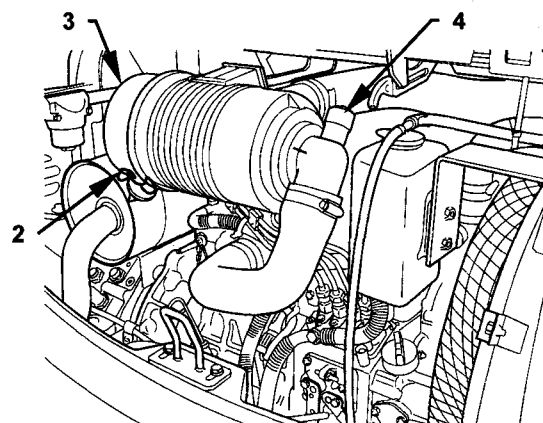

ZAXIS30, 35

M1LS-07-008

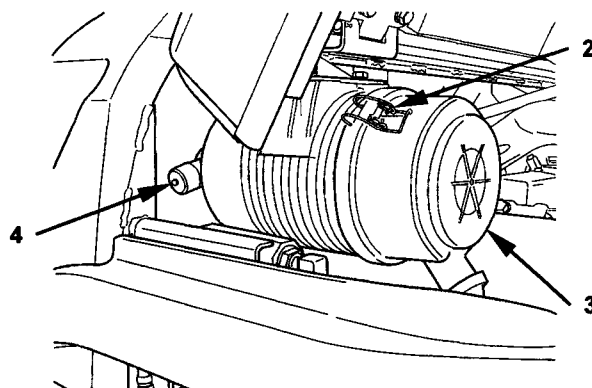

ZAXIS40, 50

M1LS-07-018

MAINTENANCE

G. COOLING SYSTEM

-  **NOTE:**
- Before leaving the Hitachi factory, the cooling system is filled with long-life coolant. As long as Hitachi Genuine Long-Life Coolant is used, the service intervals between changing the coolant is once every two years (in autumn), or every 2000 hours, whichever comes first.
 - Shorten the maintenance interval when the machine is operated in dusty areas.

1. Coolant:
Fill the radiator with soft, pure tap or bottled water.
2. Anti-rust agent:
Add 0.14 L (0.15 US qt) anti-rust agent to the new coolant when the coolant is changed. It is not necessary to add anti-rust agent when antifreeze is used.
3. Antifreeze:
If the air temperature is expected to fall below 0°C (32°F), fill the cooling system with an antifreeze and soft water mix. As a general rule, the ratio of antifreeze should range between 30% and 60% as shown in the table below. If the ratio is below 30%, the system may develop rust, and if it is above 60% the engine may overheat.

Antifreeze Mixing Table

Mixing ratio	%	30	35	40	45	50
Air temperature °C (°F)		-10 (14)	-15 (5)	-20 (-4)	-25 (-13)	-30 (-22)

Quantity of coolant: 4.8 L (1.3 US gal)

-  **CAUTION:**
- Antifreeze is poisonous; if ingested, it can cause serious injury or death. Induce vomiting and get emergency medical attention immediately.
 - When storing antifreeze be sure to keep it in a clearly marked container with tight closing lid. Always keep antifreeze out of the reach of children.
 - If antifreeze is accidentally splashed in the eyes, flush the eyes with water for 10 to 15 minutes and get emergency medical attention.
 - When storing or disposing of antifreeze, be sure to comply with all local regulations.

MAINTENANCE

1

Check Coolant Level --- daily

CAUTION: Do not loosen radiator filler cap (1) unless the system is cool. Loosen the cap slowly to the stop. Release all pressure before removing the cap.

With the engine cold, the coolant level must be between the FULL and LOW marks on coolant reservoir (2). If the coolant level is below the low mark, add coolant to coolant reservoir (2).

If coolant reservoir (2) is empty, add coolant to the radiator and then to the coolant reservoir.

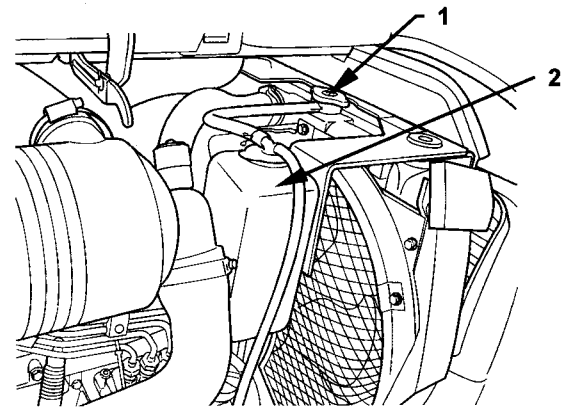

ZAXIS30, 35

M1LS-07-005

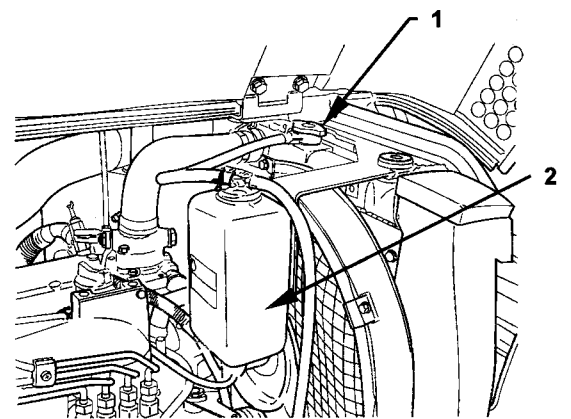

ZAXIS40, 50

M1LS-07-019

MAINTENANCE

2

Check and Adjust Fan Belt Tension

--- every 100 hours (first time after 50 hours)

IMPORTANT: Loose fan belt tension may result in insufficient battery charging, engine overheating as well as a rapid, abnormal belt wear. Belts that are too tight, however, can damage both bearings and belts.

Visually check the belt for wear. Replace if necessary. Check fan belt tension by depressing the mid-point with the thumb. Deflection must be A at a depressing force of approximately 98 N (10 kgf, 22 lbf).

A: 7 to 9 mm (0.3 to 0.4 in) (between fan (1) and Alternator (2) pulley)

If tension is not within specification, adjust Belt tension as follows:

1. Loosen alternator mounting bolt (3) and (4)
2. Adjust fan belt bolt (5) until tension is correct.

Tighten alternator mounting bolt (3) and (4)

NOTE: When a new belt is installed, be sure to readjust the tension after operating the engine for 3 to 5 minutes at slow idle speed to be sure that the new belt is seated correctly.

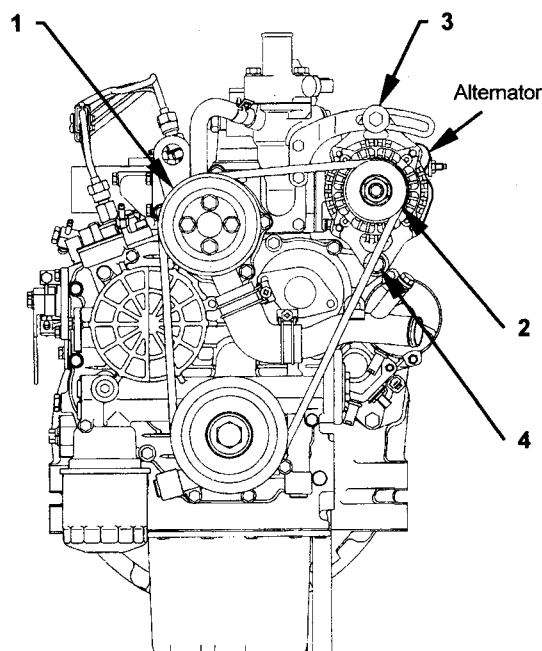
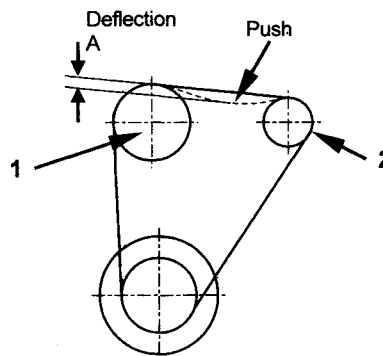

M589-07-014

M1LS-07-020

MAINTENANCE

3

Change Coolant

--- twice a year (in spring and autumn)

NOTE: Before leaving the Hitachi Factory, the cooling system is filled with Long-Life Coolant. As long as Hitachi Genuine Long-Life Coolant is used, the service intervals between changing the coolant is once every two years (in autumn), or every 2000 hours, whichever comes first.



CAUTION:

- Do not loosen radiator cap (1) until the system is cool. Loosen cap (1) slowly to the stop. Release all pressure before removing cap (1).
- When storing or disposing of antifreeze, be sure to comply with all local regulations.

1. Remove radiator cap (1). Open drain cock (2) on the radiator and drain the cock on the engine block to allow the coolant to drain completely.
2. Close drain cocks. Fill the radiator with tap water and a radiator cleaner agent. Start the engine and run it at a speed slightly higher than slow idle; when the needle of the temperature gauge reaches the white zone, run the engine for about ten more minutes.
3. Stop the engine and open drain cock (2) on the radiator. Flush out the cooling system with tap water, until draining water is clear. This helps remove rust and sediment.
4. Close drain cock (2) on the radiator. Fill the radiator with tap water and an anti-rust agent or antifreeze at the specified mixing ratio. When adding coolant, do so slowly to avoid mixing air bubbles in the system.
5. Run the engine to sufficiently bleed the air from the cooling system.
6. After adding coolant, operate the engine for several minutes. Check the coolant level again, and add coolant if necessary.
7. Install the radiator cap (1).

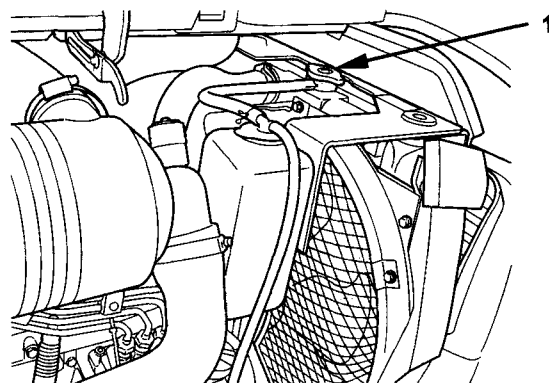

ZAXIS30, 35

M1LS-07-005

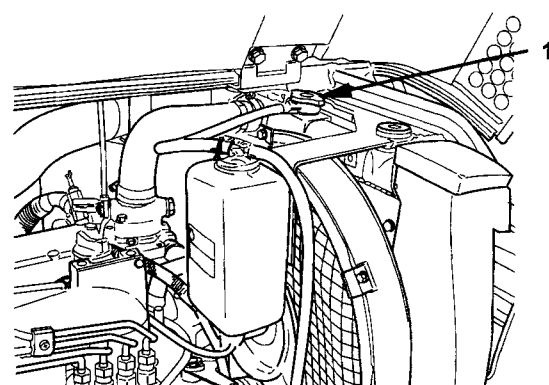

ZAXIS40, 50

M1LS-07-019

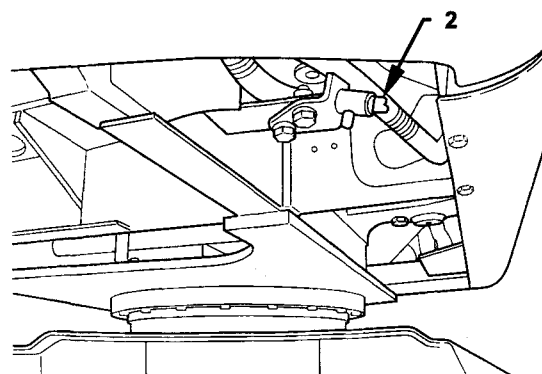

ZAXIS30, 35

M1LS-07-022

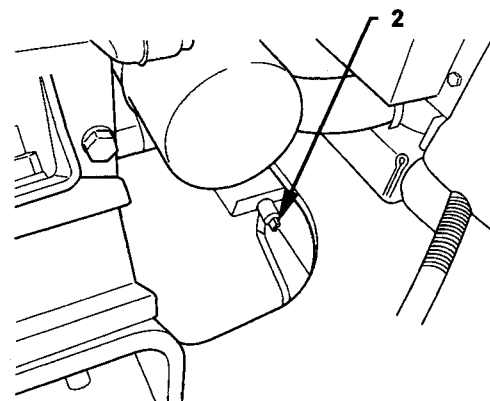

ZAXIS40, 50

M1LS-07-023

MAINTENANCE

4

Clean Radiator
--- every 500 hours



CAUTION: Always wear safety glasses or goggles when using compressed air to clean radiator core.

IMPORTANT:

- Cover air cleaner inlet opening to prevent entry of dust and water while cleaning the radiator core.
- High-pressure air or water can damage radiator fins. When cleaning the radiator core with high-pressure air or water, keep the nozzle 500 mm (19.7 in) or more away from the core face.

To maintain the cooling capacity of the radiator, clean the radiator core with compressed air (less than 0.2 MPa, 2 kgf/cm²) or water when dust and dirt become stuck on it. Clean the oil cooler with compressed air or water when cleaning the radiator core.

MAINTENANCE

H. ELECTRICAL SYSTEM

IMPORTANT: Improper radio communication equipment and associated parts, and/or improper installation of radio communication equipment effects the machine's electronic parts, causing involuntary movement of the machine. Also, improper installation of electrical equipment's may cause machine failure and/or a fire on the machine. Be sure to consult your authorized dealer when installing a radio communication equipment or additional electrical parts, or when replacing electrical parts.

Never attempt to disassemble or modify the electrical/electronic components. If replacement or modification of such components is required, contact your authorized dealer.



SA-032

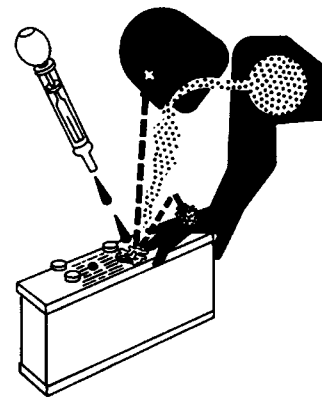

SA-036

BATTERIES

CAUTION: Battery gas can explode. Keep sparks and flames away from batteries. Use a flashlight to check the battery electrolyte level.

Do not continue to use or charge the battery when electrolyte level is lower than specified. Explosion of the battery may result.

Sulfuric acid in battery electrolyte is poisonous. It is strong enough to burn skin, eat holes in clothing, and cause blindness if splashed into the eyes.

Avoid hazard by:

- Filling batteries in a well-ventilated area.
- Wearing eye protection and rubber gloves.
- Avoiding breathing fumes when electrolyte is added.
- Avoiding spilling or dripping electrolyte.
- Using proper booster battery starting procedures.

If you spill acid on yourself:

- Flush your skin with water.
- Apply baking soda or lime to help neutralize the acid.
- If splashed in eyes, flush with water for 10 to 15 minutes. Get medical attention immediately.

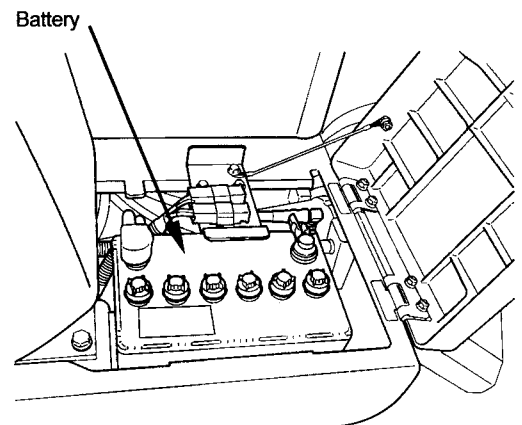

M1LS-03-002

MAINTENANCE

If acid is swallowed:

- Drink large amounts of water or milk.
- Then drink milk of magnesia, beaten eggs, or vegetable oil.
- Get medical attention immediately.

IMPORTANT: Add water to batteries in freezing weather before you begin operating your machine for the day, or else charge the batteries.

IMPORTANT: If the battery is used with the electrolyte level lower than the specified lower level, the battery may deteriorate quickly.

IMPORTANT: Don't refill electrolyte more than the specified upper level. Electrolyte may spill, damaging the painted surfaces and/or corroding other machine parts.

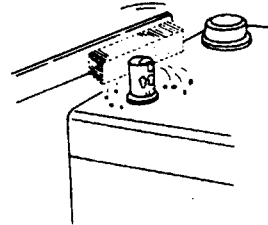

M409-07-072

 **NOTE:** In case electrolyte is refilled more than the specified upper level line or beyond the bottom end of the sleeve, remove the excess electrolyte until the electrolyte level is down to the bottom end of the sleeve using a pipette. After neutralizing the removed electrolyte with sodium bicarbonate, flush it with plenty of water, otherwise, consult the battery manufacturer.

MAINTENANCE

Electrolyte Level Check

1. Check the electrolyte level at least once a month.
2. Park the machine on level ground and stop the engine.
3. Check the electrolyte level.
 - 3.1 When checking the level from the battery side:
Clean around the level check lines with a wet towel. Don't use a dry towel. Static electricity may be developed, causing the battery gas to explode. Check if the electrolyte level is between U.L (Upper Level) and L.L (Lower Level). In case the electrolyte level is lower than the middle level between the U.L and L.L, immediately refill distilled water or commercial battery fluid. Be sure to refill with distilled water before recharging (operating the machine). After refilling, securely tighten the filler plug.
 - 3.2 When impossible to check the level from the battery side or no level check mark is indicated on the side:
After removing the filler plug from the top of the battery. Check the electrolyte level by viewing through the filler port. It is difficult to judge the accurate electrolyte level in this case. Therefore, when the electrolyte level is flush with the U.L, the level is judged to be proper. Then, referring to the right illustrations, check the level. When the electrolyte level is lower than the bottom end of the sleeve, refill with distilled water or commercial battery fluid up to the bottom end of the sleeve. Be sure to refill with distilled water before recharging (operating the machine). After refilling, securely tighten the filler plug.
 - 3.3 When an indicator is available to check the level, follow its check result.
4. Always keep around the battery terminals clean to prevent battery discharge. Check terminals for loose and/or rust. Coat terminals with grease or petroleum jelly to prevent corrosion build up.

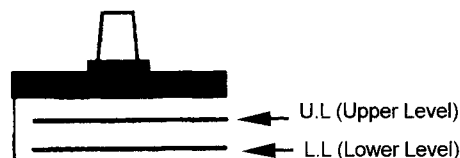

M146-07-109

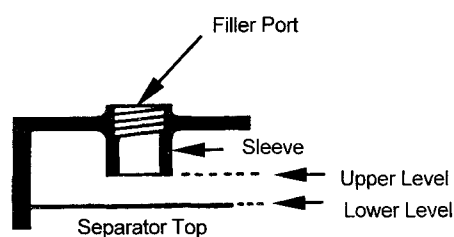

M146-07-110

Proper



Since the electrolyte surface touches the bottom end of the sleeve, the electrolyte surface is raised due to surface tension so that the electrode ends are seen curved.

M146-07-111

Lower



When the electrolyte surface is lower than the bottom end of the sleeve, the electrode ends are seen straight.

M146-07-112

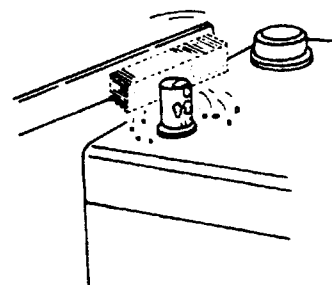

M409-07-072

MAINTENANCE

Check electrolyte specific gravity



CAUTION: Battery gas can explode. Keep sparks and flames away from batteries. Use a flashlight to check the battery electrolyte level.

Sulfuric acid in battery electrolyte is poisonous. It is strong enough to burn skin, eat holes in clothing, and cause blindness if splashed into the eyes.

Never check the battery charge by placing a metal object across the posts. Use a voltmeter or hydrometer.

Always remove the grounded (-) battery clamp first and replace it last.

Avoid hazard by:

- Filling batteries in a well-ventilated area.
- Wearing eye protection and rubber gloves.
- Avoiding breathing fumes when electrolyte is added.
- Avoiding spilling or dripping electrolyte.
- Using proper booster battery starting procedures.

If you spill acid on yourself:

- Flush your skin with water.
- Apply baking soda or lime to help neutralize the acid.
- If splashed in eyes, flush with water for 10 to 15 minutes. Get medical attention immediately.

If acid is swallowed:

- Drink large amounts of water or milk.
- Then drink milk of magnesia, beaten eggs, or vegetable oil.
- Get medical attention immediately.

IMPORTANT: Check the specific gravity of the electrolyte after it is cooled, not immediately after operation.

Check the electrolyte specific gravity in each battery cell.

The lowest limit of the specific gravity for the electrolyte varies depending on electrolyte temperature. The specific gravity should be kept within the range shown below. Charge the battery if the specific gravity is below the limit.

Recommended range of specific gravity by electrolyte temperature

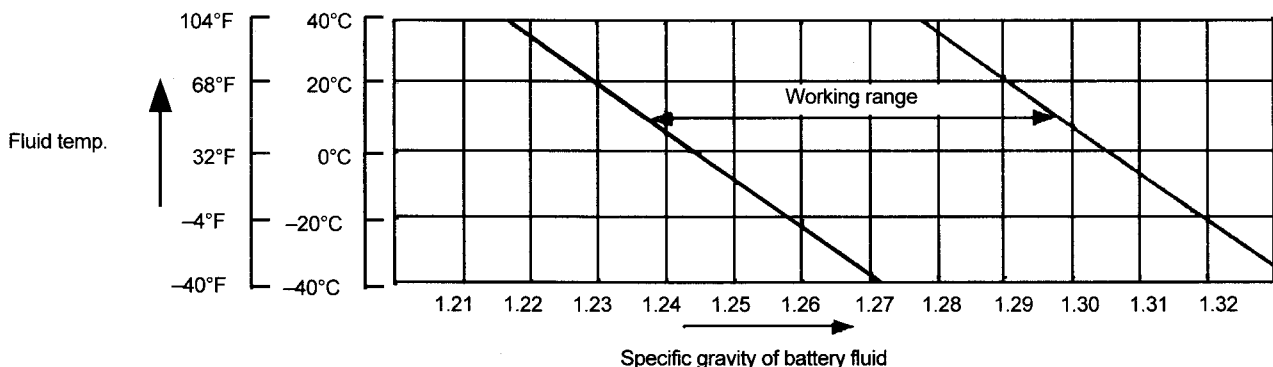

MAINTENANCE

REPLACING FUSES

If any electrical equipment fails to operate, first check the fuses. Fuse box is located the side of the switch panel. A fuse location/specification decal is attached to the fuse box cover.

Remove the fuse box cover by lifting it upward. Spare fuses are located on the underside of the cover.

IMPORTANT: Be sure to install fuses with correct amperage ratings to prevent electrical system damage from due to overload.

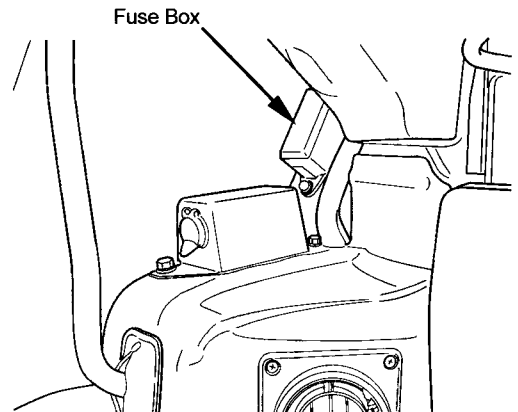

M1LS-07-021

- | | |
|--|-----|
| 1- Air Conditioner or Heater | 20A |
| 2- Monitor, Electrical Socket | 20A |
| 3- Light | 20A |
| 4- Horn
Travel Fast Speed
Pilot control Shut-off lever | 15A |
| 5- Air Conditioner
Wiper | 15A |

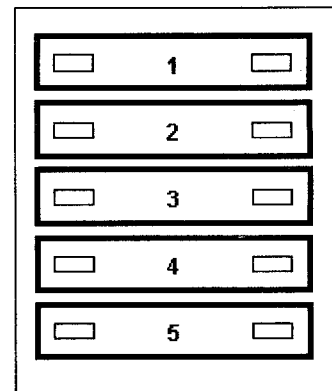

M1LS-07-003

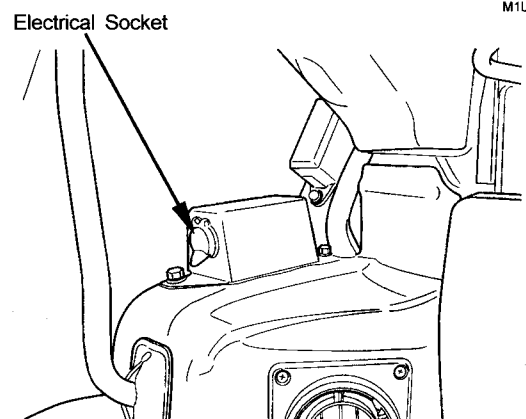

M1LS-07-021

ELECTRICAL SOCKET

Use: Connection of a lighting device for service and maintenance.

Specification of electrical socket: As per DIN ISO4165.
Multiple socket. maximum charge 8A at 12V.

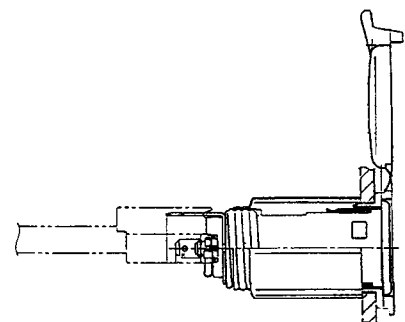

M586-07-003

MAINTENANCE

I. MISCELLANEOUS

1 Check Bucket Teeth --- daily

1. Check the bucket teeth for wear and looseness.
2. Replacement procedure:
 - (1) Raise the Bucket and position the Bucket bottom Horizontally. Lower the Bucket to approximately 500 mm (20 inch) above the ground. Use supporting blocks for safety.
 - (2) Loosen M12 nuts (2) and remove M12 bolts (1). Remove Tooth (3) from the Bucket.
 - (3) Install new Tooth (3) onto the Bucket. Insert shims (4) (thickness : 0.4mm, 1.0 mm) between the Tooth and Bucket, when installing the Tooth.
 - (4) Tighten Bolts (1) and Nuts (2) to 108 N.m (11 kgf.m)
 - (5) After operating the Bucket for a few hours, retghten Nuts (2).

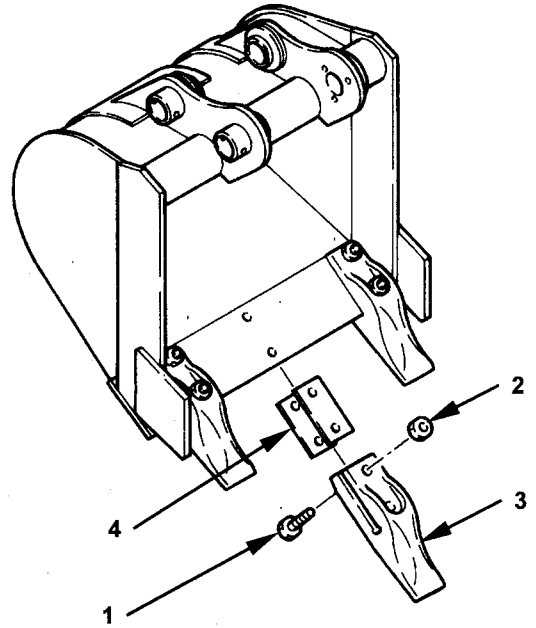

M503-07-085

MAINTENANCE

2

Replace Bucket



CAUTION: When driving the connecting pins in or out, guard against injury from flying pieces of metal or debris; wear goggles or safety glasses, and safety equipment appropriate for the job.

1. Park the machine on a level surface. Lower the bucket to the ground and position it with the flat surface resting on the ground. Be sure the bucket will not roll when the pins are removed.
2. Slide the O-rings out of the way as shown.
3. Remove bucket pins A and B to separate the arm and bucket. Clean the pins and pin bores. Apply sufficient grease to the pins and pin bores.
4. Align the arm and alternate bucket. Be sure the bucket is stabilized and will not roll.
5. Install the bucket pins A and B.
6. Install the locking pins and snap ring on pins A and B.
7. Adjust bucket linkage clearance for pin A. See adjusting bucket linkage clearance procedure.
8. Apply grease to pin joints A and B.
9. Start the engine and run it at slow idle. Slowly operate the bucket in both directions to check for any interference in bucket movement. Do not attempt to operate a machine, if any movement interference is found. Correct interference problem.

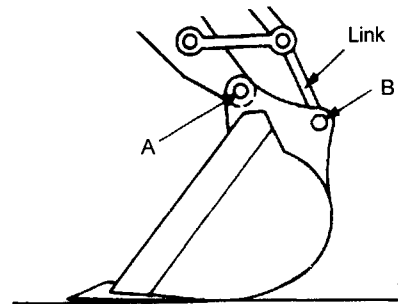
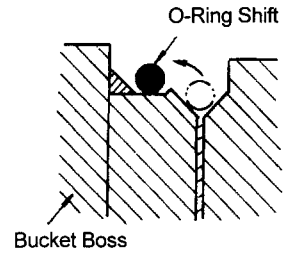

M104-07-063

MAINTENANCE

3

Check Track Sag (rubber crawler) --- every 8 working hours

Proper track sag adjustment is necessary to extend the service life of the rubber track and the travel device.

Check Track Sag

1. Position the blade to the rear of the upperstructure. Lower the bucket and blade to raise both tracks off ground, as shown. Place blocks under machine frame to support the machine.
2. Rotate the rubber track so that the track joint is positioned at the upper center of the track.

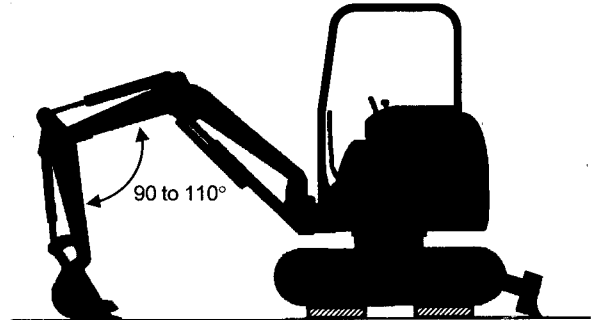

M586-07-004

At the center lower roller, measure distance (A) from the bottom of the lower roller to the inner ridge of the rubber track.

Track Sag Specifications (dimension A): 10 to 15 mm (0.39 to 0.59 in)

Precautions for Adjusting Track Sag

1. If track sag is not within specifications, loosen or tighten the track following the procedures shown on the next page.
2. Before adjusting track sag, lower the bucket and blade to the ground to raise both tracks off the ground as shown above. Be sure to place blocks under machine frame to support the machine.
3. After adjusting track sag of both tracks, run the tracks back and forth several times.
4. After doing so, check track sag again. If track sag is not within specifications, repeat adjustment until correct sag is obtained.

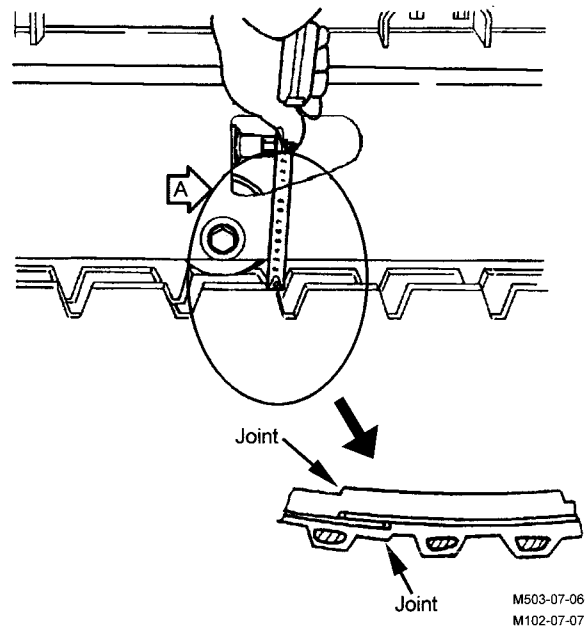

M503-07-060
M102-07-075

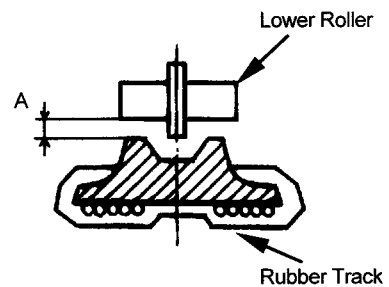

M503-05-050

MAINTENANCE

Loosen Track

CAUTION: Do not loosen valve (1) too quickly or too much as high-pressure grease in the adjusting cylinder may spout out. Loosen carefully, keeping body parts and face away from valve (1). Never loosen grease fitting (2).

IMPORTANT: When gravel or mud is packed between sprockets and track links, remove it before loosening valve (1).

1. To loosen track, slowly turn valve (1) counterclockwise using a socket wrench (long socket 19); grease will escape from grease outlet.
2. Between 1 and 1.5 turns of valve (1) are sufficient to loosen track.
3. If grease does not drain smoothly, slowly rotate the track.
4. When proper track sag is obtained, turn valve (1) clockwise and tighten it to 88 N·m (9 kgf·m, 65 lbf·ft).

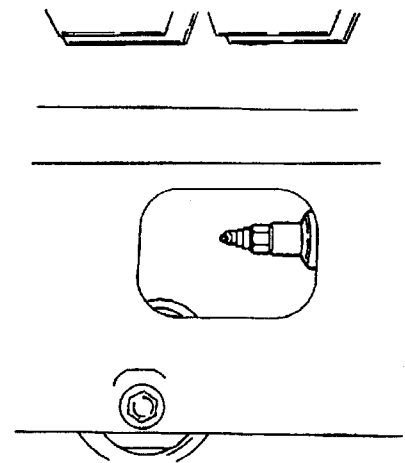
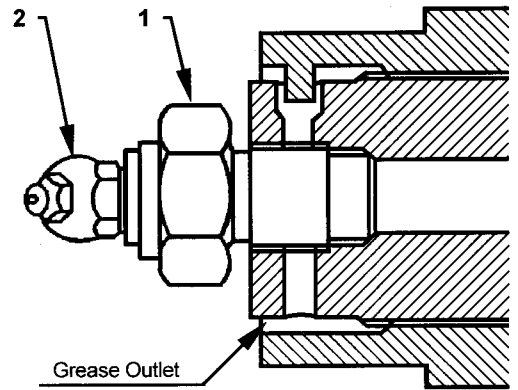

Tighten Track

CAUTION: It is abnormal if track is still tight after turning valve (1) counterclockwise or track is still loose after charging grease to grease fitting (2). In such cases, NEVER ATTEMPT TO DISASSEMBLE the track shoes or track adjuster, because of dangerous high-pressure grease inside the track adjuster. See your authorized dealer immediately.

To tighten track, connect a grease gun to grease fitting (2) and add grease until the sag is within specifications.

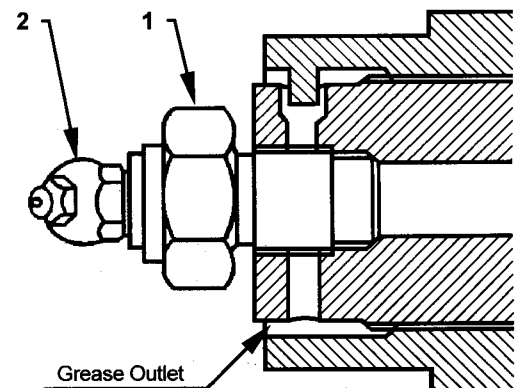

MAINTENANCE

4

Replace Rubber Track

CAUTION: Do not loosen valve (1) quickly or loosen it too much as high-pressure grease in the adjusting cylinder may spout out. Loosen carefully, keeping body parts and face away from valve (1). Never loosen grease fitting (2). When removing the rubber track, do not allow anyone to stand in front of the front idler. During this procedure, the high power track adjuster may suddenly release the front idler with extreme force, potentially resulting in personal injury or death.

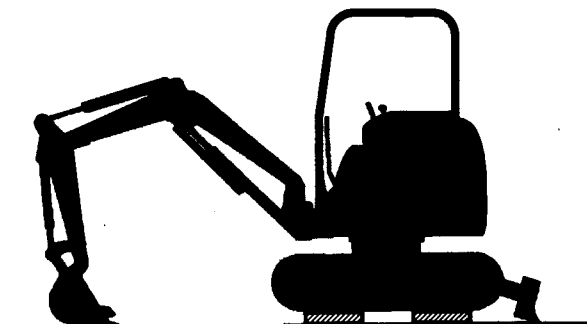

M586-07-004

1. Removing Rubber Track

- (1) Position the blade to the rear of the upperstructure. Lower the bucket and blade to raise both tracks off ground, as shown. Place blocks under machine frame to support the machine.
- (2) Slowly turn valve (1) counterclockwise using a wrench; grease will escape from grease outlet.
- (3) Insert two or three steel pipes into gaps among lower rollers, track frame and rubber track and slowly rotate the track in reverse to lift the rubber track off the idler. Apply horizontal force to pry the rubber lower from the idler.

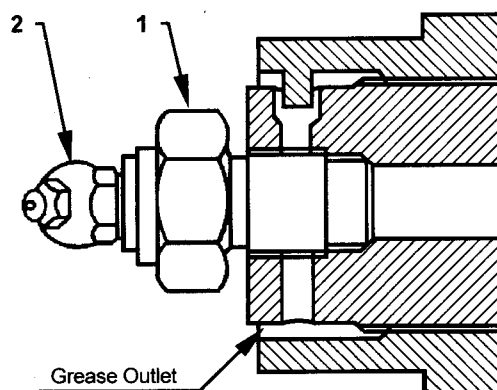

M104-07-119

2. Installing Rubber Track

- (1) Position the blade to the rear of the upperstructure. Lower the bucket and blade to raise both tracks off ground, as shown. Place blocks under machine frame to support the machine.
- (2) Slowly turn valve (1) counterclockwise using a wrench; grease will escape from the grease outlet.
- (3) Engage the rubber track with the sprocket and position the other end of the rubber track on the front idler.
- (4) While rotating the sprocket in reverse, apply horizontal force to the rubber track to seat it on the idler.
- (5) Insert a steel pipe into gaps among lower rollers, track frame and rubber track and rotate the rubber track slowly in reverse to correctly seat the rubber track on the idler.
- (6) Confirm that the rubber track is correctly engaged with the sprocket and idler.
- (7) Adjust track sag. (See page 7-55 and 7-56.)
- (8) Lower the machine to the ground.

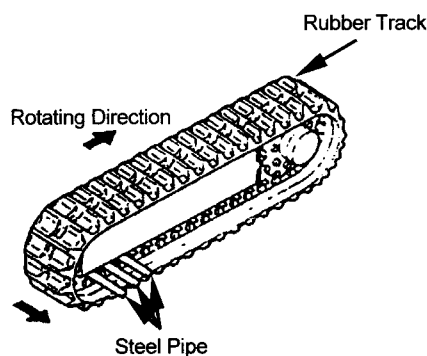

M503-07-062

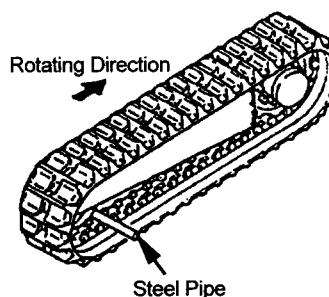

M503-07-063

MAINTENANCE

5

Check Track Sag (steel crawler) --- every 50 working hours

Proper adjustment of track sag is vital to extending the service life of the track and travel device.

Check Track Sag

Swing upperstructure 90° and lower bucket to raise track off ground, as shown.

Keep the angle between boom and arm 90 to 110° and position the bucket's round side on the ground. Place blocks under the machine frame to support the machine. Rotate the track in reverse two full rotations and then forward two full rotations.

Measure distance (A) at the middle of track frame from the bottom of track frame to the back face of the track shoe.

Track sag specifications

ZAXIS30, 35: 120 to 140 mm (4.8 to 5.5 in)

ZAXIS40, 50: 140 to 160 mm (5.5 to 6.3 in)

 **NOTE:** Check track sag after thoroughly removing soil stuck on track area by washing.

Precautions for Adjusting Track Sag

1. If track sag is not within specifications, loosen or tighten the track following the procedures shown on the next page.
2. When adjusting track sag, lower the bucket to the ground to raise one track off the ground. Repeat this procedure to raise the other lower. Each time, be sure to place blocks under machine frame to support the machine.
3. After adjusting track sag of both tracks, move the machine back and forth several times.
4. Check track sag again. If track sag is not within specification, repeat adjustment until correct sag is obtained.

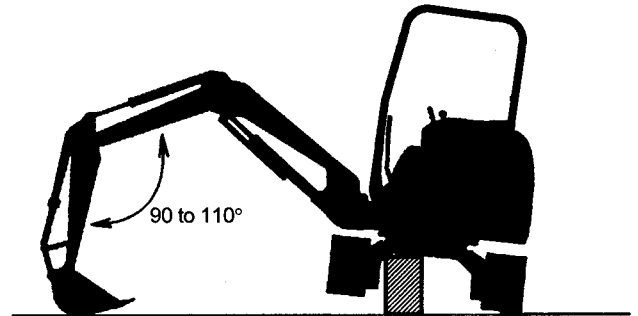

M586-07-005

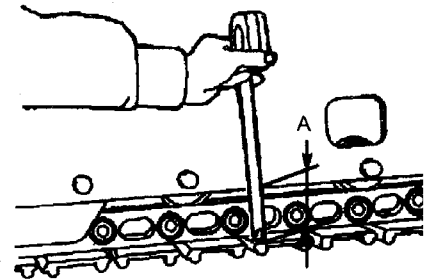

M552-07-089

MAINTENANCE

Loosen Track

CAUTION: Do not loosen valve (1) quickly or loosen it too much as high-pressure grease in the adjusting cylinder may spout out. Loosen carefully, keeping body parts and face away from valve (1). Never loosen grease fitting (2).

IMPORTANT: When gravel or mud is packed between sprockets and track links, remove it before loosening.

1. To loosen track, slowly turn valve (1) counterclockwise using a wrench (width across flat: 19); grease will escape from grease outlet.
2. Between 1 to 1.5 turns of valve (1) are sufficient to loosen track.
3. If grease does not drain smoothly, slowly rotate the raised track.
4. When proper track sag is obtained, turn valve (1) clockwise and tighten it.
Tightening torque 88 N·m (9 kgf·m, 65 lbf·ft)

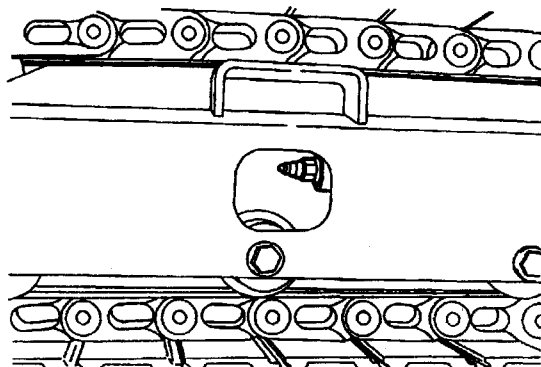

M103-07-058

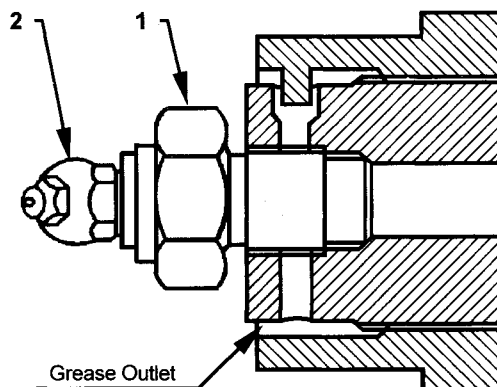

M104-07-119

Tighten Track

CAUTION: It is abnormal if track is still tight after turning valve (1) counterclockwise or track is still loose after charging grease to fitting (2). In such cases, NEVER ATTEMPT TO DISASSEMBLE the track shoes or track adjuster, because of dangerous high-pressure grease inside the track adjuster. See your authorized dealer immediately.

To tighten track, connect a grease gun to grease fitting (2) and add grease until the sag is within specifications.

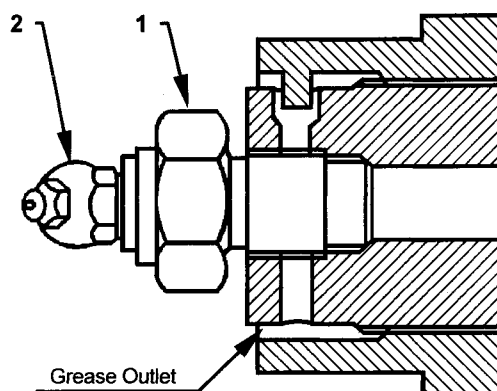

M104-07-119

MAINTENANCE

Converting the Track

The rubber track uses a track adjuster different from that used for the steel track.



CAUTION:

- **Before converting the track, contact your nearest authorized dealer. Be sure to change front idlers and track adjusters when converting the track from steel to rubber or rubber to steel. When doing so, never attempt to disassemble the track adjuster, as high-pressure grease inside the track adjuster can cause serious injury if released. When replacement or adjustment of the rubber track is required, contact your nearest authorized dealer. The track adjuster spring setting force is quite large. Do not allow anyone to stand in front of the front idler. Do not attempt to disassemble the track adjuster.**
- **With the track removed, the idler will be free to come off. Be sure to take measures to keep the idler in position before removing the track.**

Change the front idlers and the track adjuster whenever converting the steel or rubber track. The front idler and the track adjuster for the steel track are provided with a decal stating "For Steel Track", whereas the front idler and the adjuster for the rubber track have no decals. Take care not to attach the wrong type of front idler and adjuster.

MAINTENANCE

6

Check and Replace Seat Belt (Option)

Check --- daily

Replace --- every 3 years

Always maintain the seat belt in a functional condition and replace when necessary to ensure proper performance.

Prior to operating the machine, thoroughly examine belt (1), buckle (2) and attaching hardware (3). If any item is damaged or materially worn, replace the seat belt or component before operating the machine.

We recommend that the seat belt be replaced every three years regardless of its apparent condition.

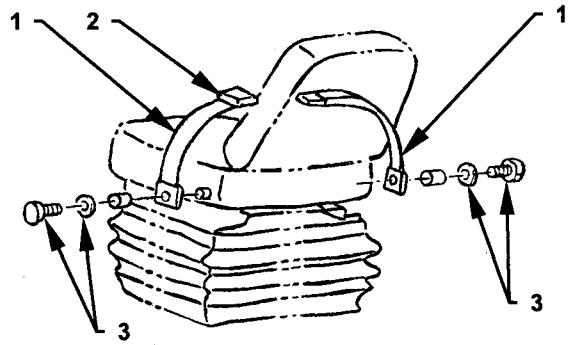

M1LN-07-029

7

Check Fuel Injection Nozzles

--- every 500 hours

Consult your authorized dealer for inspection and repair.

8

Check and Adjust Valve Clearance

--- every 1000 hours

Consult your authorized dealer for inspection and repair.

MAINTENANCE

9 **Check Injection Timing --- as required**
Consult your authorized dealer for inspection and repair.

10 **Measure Engine Compression Pressure
--- every 1000 hours**
Consult your authorized dealer for inspection and repair.

11 **Check Starter and Alternator
--- every 1000 hours**
Consult your authorized dealer for inspection and repair.

12 **Check Radiator Cap --- as required**
Consult your authorized dealer for inspection and repair.

MAINTENANCE

13 Check Tightening Torque of Bolts and Nuts --- every 250 Hours (first time after 50 hours)

Check tightness after the first 50 hours then every 250 hours. Tighten to torque shown if any are loose. Bolts and nuts should be replaced with those of the same or higher grade.

For tightening nuts and bolts other than specified in the table below, refer to the Tightening Torque Chart at the end of this section.

IMPORTANT: Check and tighten bolts and nuts using a torque wrench.

ZAXIS30, 35

No.	Descriptions	Bolt Dia. mm	Q'ty	Wrench Size mm	Torque		
					N-m	(kgf-m)	(lbf-ft)
1.	Engine cushion rubber mounting bolt	12	4	19	88	(9)	(65)
2.	Engine bracket mounting bolt (Front)	10	8	17	49	(5)	(36)
	Engine bracket mounting bolt (Rear)	10	6	17	49	(5)	(36)
3.	Hydraulic oil tank and Fuel tank mounting bolt	10	5	17	49	(5)	(36)
4.	Fitting for hydraulic hoses and piping	PF 1/4		19	29.5	(3)	(22)
		PF 3/8		22	39	(4)	(29)
		PF 1/2		27	64	(6.5)	(47)
5.	Pump mounting bolt	12	2	19	88	(9)	(65)
6.	Pump cover mounting bolt	10	6	17	49	(5)	(36)
7.	Control valve mounting bolt	10	4	17	49	(5)	(36)
	Control valve base mounting bolt	10	5	17	49	(5)	(36)
8.	Swing device mounting bolt	14	6	22	137	(14)	(101)
9.	Battery mounting bolt	8	2	13	9.8	(1)	(7.2)
		10	2	17	49	(5)	(36)
10.	Cab/Canopy mounting bolt	10	13	17	49	(5)	(36)
11.	Floor mounting bolt	16	4	24	205	(21)	(152)
12.	Swing bearing mounting bolt to upperstructure	12	22	19	108	(11)	(80)
	Swing bearing mounting bolt to undercarriage	12	20	19	108	(11)	(80)
13.	Travel device mounting bolt	12	22	19	128	(13)	(94)
14.	Sprocket mounting bolt	12	22	19	128	(13)	(94)
15.	Upper roller mounting bolt	12	2	19	88	(9)	(65)
16.	Lower roller mounting bolt	14	16	22	245	(25)	(181)
17.	Cover mounting bolt	8		13	9.8	(1)	(7)
		10		17	49	(5)	(36)
		12		19	88	(9)	(65)
18.	Counterweight mounting bolt	22	2	32	540	(55)	(400)

MAINTENANCE

13

Check Tightening Torque of Bolts and Nuts --- every 250 Hours (first time after 50 hours)

Check tightness after the first 50 hours then every 250 hours. Tighten to torque shown if any are loose. Bolts and nuts should be replaced with those of the same or higher grade.

For tightening nuts and bolts other than specified in the table below, refer to the Tightening Torque Chart at the end of this section.









IMPORTANT: Check and tighten bolts and nuts using a torque wrench.

ZAXIS40, 50

No.	Descriptions	Bolt Dia. mm	Q'ty	Wrench Size mm	Torque		
					N.m	(kgf-m)	(lbf-ft)
1.	Engine cushion rubber mounting nut	14	4	22	137	(14)	(101)
	Engine cushion rubber mounting bolt	16	2	24	205	(21)	(152)
2.	Engine bracket mounting bolt (Front)	12	8	19	88	(9)	(65)
	Engine bracket mounting bolt (Rear)	10	8	17	49	(5)	(36)
3.	Hydraulic oil tank and Fuel tank mounting bolt	10	5	17	49	(5)	(36)
4.	Fitting for hydraulic hoses and piping	PF 1/4		19	29.5	(3)	(22)
		PF 3/8		22	39	(4)	(29)
		PF 1/2		27	64	(6.5)	(47)
5.	Pump mounting bolt	12	2	10	108	(11)	(80)
6.	Pump cover mounting bolt	10	6	17	49	(5)	(36)
7.	Control valve mounting bolt	10	4	17	49	(5)	(36)
	Control valve base mounting bolt	10	5	17	49	(5)	(36)
8.	Swing device mounting bolt	16	8	24	205	(21)	(152)
9.	Battery mounting nut	8	2	13	9.8	(1)	(7.2)
		10	2	17	49	(5)	(36)
10.	Cab/Canopy mounting bolt	10	13	17	49	(5)	(36)
11.	Floor mounting bolt	16	4	24	205	(21)	(152)
12.	Swing bearing mounting bolt to upperstructure	14	22	22	175	(18)	(130)
	Swing bearing mounting bolt to undercarriage	12	20	19	108	(11)	(80)
13.	Travel device mounting bolt	12	26	19	128	(13)	(94)
14.	Sprocket mounting bolt	12	24	19	128	(13)	(94)
15.	Upper roller mounting bolt	14	2	22	137	(14)	(101)
16.	Lower roller mounting bolt	18	16	27	451	(46)	(332)
17.	Cover mounting bolt	8		13	9.8	(1)	(7)
		10		17	49	(5)	(36)
		12		19	88	(9)	(65)
18.	Counterweight mounting bolt	18	3	27	295	(30)	(217)

MAINTENANCE

Tightening Torque Chart

Bolt Dia.	Wrench Size	Hexagon Wrench Size	   M552-07-091			   M552-07-090 Socket Bolt			  M157-07-225		
			N·m	(kgf·m)	(lbf·ft)	N·m	(kgf·m)	(lbf·ft)	N·m	(kgf·m)	(lbf·ft)
M8	13	6	30	(3.1)	(22)	20	(2.0)	(15.0)	10	(1.0)	(7.4)
M10	17	8	65	(6.6)	(48)	50	(5.1)	(37)	20	(2.0)	(15.0)
M12	19	10	110	(11.0)	(81)	90	(9.2)	(66)	35	(3.6)	(26.0)
M14	22	12	180	(18.5)	(135)	140	(14.0)	(103)	55	(5.6)	(41)
M16	24	14	270	(27.5)	(200)	210	(21.5)	(155)	80	(8.2)	(59)
M18	27	14	400	(41.0)	(295)	300	(30.5)	(220)	120	(12.0)	(89)
M20	30	17	550	(56.0)	(410)	400	(41.0)	(295)	170	(17.0)	(125)
M22	32	17	750	(76.5)	(550)	550	(56.0)	(410)	220	(22.5)	(162)
M24	36	19	950	(97.0)	(700)	700	(71.5)	(520)	280	(28.5)	(205)
M27	41	19	1400	(143)	(1030)	1050	(107)	(770)	400	(41.0)	(295)
M30	46	22	1950	(200)	(1440)	1450	(148)	(1070)	550	(56.0)	(410)
M33	50	24	2600	(265)	(1920)	1950	(200)	(1440)	750	(76.5)	(550)
M36	55	27	3200	(325)	(2360)	2450	(250)	(1810)	950	(97.0)	(700)

IMPORTANT: Make sure bolt and nut threads are clean before installing.
 Apply lubricant (e. g. white zinc B solved into spindle oil) to bolts and nuts to stabilize their friction coefficient.

 **NOTE:** Tightening torque required is shown in N·m.
 For example, when tightening a bolt or nut with a wrench of 1 m length, turning the end of it with a force of 120 N, the torque produced will be:

$$1 \text{ m} \times 120 \text{ N} = 120 \text{ N}\cdot\text{m}$$

To produce the same torque with a wrench of 0.25 m:

$$0.25 \text{ m} \times \boxed{} \text{ N} = 120 \text{ N}\cdot\text{m}$$

Necessary force will be:

$$120 \text{ N}\cdot\text{m} \div 0.25 \text{ m} = 480 \text{ N}$$

MAINTENANCE

OFTEN-REPLACED PARTS

Filter Element Parts Number

	ZAXIS30, 35	ZAXIS40, 50
Hydraulic Oil Tank Filter	4294132	4272372
Suction Filter	4294131	←
Pilot Filter	4294130	←
Engine Oil Filter	4294838	4366703
Fuel Filter	4413286	4366704
Air Cleaner Element	4417516	←
Water Separator	4418776	←

Bucket Parts

Item	Model	ZAXIS30, 35		ZAXIS40, 50	
		Parts No.	Q'ty	Parts No.	Q'ty
Tooth	Teeth	E3056107	4	E3056107	4
	Shim (1.0 mm)	E4276602	8	E4276602	8
	Shim (0.4 mm)	E4276605	8	E4276605	8
	Bolt	EJ981245	8	EJ981245	8
	Nut	EJ231212	8	EJ231212	8
Side Cutter	Side Cutter (R)	E3056344	1	E3061850	1
	Side Cutter (L)	E3056345	1	E3061851	1
	Bolt	EJ981440	6	E4317650	6
	Nut	EJ231214	6	←	6
	Spring Washer	EJ252214	6	←	6
O-Ring		4275463	(4) 2	4275520	(4) 2

 NOTE: (1) Quantities between Brackets (), include O-rings used for bucket and link connections.

(2) Optional buckets may have different part quantities.

MAINTENANCE

MAINTENANCE UNDER SPECIAL ENVIRONMENTAL CONDITIONS

Operating Conditions	Precautions for Maintenance	
Muddy Soil, Rainy or Snowy Weather	Before Operation: After Operation:	Check the tightness of plugs and all drain cocks. Clean the machine and check for cracks, damaged, loose or missing bolts and nuts. Lubricate all necessary part without delay.
Near the Ocean	Before Operation: After Operation:	Check the tightness of plugs and all drain cocks. Thoroughly clean the machine with fresh water to wash off salt. Service electrical equipment often to prevent corrosion.
Dusty Atmosphere	Air Cleaner: Radiator: Fuel System: Electrical Equipment:	Clean the element regularly, at shorter service intervals. Clean the screen to prevent clogging of the radiator core. Clean the filter element and strainer regularly, at shorter service intervals. Clean them regularly, in particular, the commutator surface of the alternator and starter.
Rocky Ground	Tracks: Front Attachment:	Carefully operate while checking for cracks, damage and loose bolts and nuts. Loosen the tracks a little more than usual. Standard attachment may be damaged when digging rocky ground. Reinforce the bucket before using it, or use a heavy duty bucket.
Freezing Weather	Fuel: Lubricant: Engine Coolant: Battery: Tracks:	Use high quality fuel suitable for low temperature. Use high quality low viscosity hydraulic oil and engine oil. Be sure to use antifreeze. Fully charge the batteries regularly with shorter service intervals. If not charged fully, electrolyte may freeze. Keep the tracks clean. Park the machine on a hard surface to prevent the tracks from freezing to the ground.
Falling Stones	Canopy:	Provide a canopy guard to protect the machine from falling stones when necessary.

STORAGE

STORING THE MACHINE

1. Thoroughly wash the machine to remove dirt, soil and debris from the machine.
2. Inspect the machine. Repair worn or damaged parts. Install new parts if necessary.
3. Clean the primary air cleaner element.
4. Lubricate all grease points.
5. Retract all hydraulic cylinders, if possible. If not, coat exposed cylinder rods with grease.
6. Park the tracks on long stable blocks.
7. Remove the batteries and store them in a dry protected place after charging fully. If not removed, disconnect the negative battery cable from the (-) terminal.
8. Add an antirust agent to the coolant. In cold weather, add an antifreeze, or drain the coolant completely. Be sure to attach a "No Water in Radiator" tag on a clearly visible location if the system is drained.
9. Loosen the alternator belt and fan belt.
10. Paint necessary areas to prevent rust.
11. Store the machine in a dry, protected place. If stored outside, cover with a waterproof cover.
12. If the machine is stored for a long time, oil films on sliding surfaces may break down. Operate the travel, swing and digging functions, 2 to 3 cycles each, to lubricate, the sliding surfaces, at least once a month. Be sure to check the coolant level and lubrication conditions before operating.

IMPORTANT:

When using hydrojet steamcleaner for washing:

- Do not use steamcleaner in the first 3 months after manufacturing of the machine.
- The distance from nozzle to paintlayer should be at least 50cm.'s.
- Never keep pointed on one area : keep the nozzle moving continuously.
- Water/cleaner temperature must not be higher than 80 degrees Celsius, "pH-grade" between 3~11.
- After using a cleaner, always rinse with water, so that no concentration of cleaner remain.

Not following above mentioned advice could result in serious paintdamage.

STORAGE

REMOVING THE MACHINE FROM STORAGE



CAUTION: Start the engine **ONLY** in a well-ventilated place.

1. Remove grease from the cylinder rods if coated.
2. Adjust alternator and fan belt tension.
3. Fill the fuel tank. Bleed air from the fuel system. Check all fluid levels.
4. Start the engine.
Run the engine at half speed for several minutes before beginning full load operation.
5. Operate all hydraulic functions several cycles.
6. Carefully check all systems before operating the machine with a full load.



NOTE: *When the machine has been stored for a long time, be sure to perform the following steps as well:*

- (a) *Check the condition of all hoses and connections.*
- (b) *Warm up the engine.*
- (c) *Stop the engine.*
- (d) *Install new fuel filters. Replace the engine oil filter and fill the engine with oil.*

IMPORTANT: **If the machine is not used for a long time, oil films on sliding surfaces may have break down. Operate the travel, swing and digging functions, 2 to 3 cycles each to lubricate the sliding surfaces.**

TROUBLESHOOTING

TROUBLESHOOTING



CAUTION: Never attempt to adjust, disassemble, or repair hydraulic or electrical components by yourself.

If any problem is found, troubleshoot to pinpoint the cause and take appropriate action to prevent the problem from occurring again. If the cause cannot be pinpointed, contact your authorized dealer.

1. Engine

Trouble	Cause	Solution
Engine does not start.	<ul style="list-style-type: none"> • Starter does not rotate • Engine is too cold • Incomplete air bleeding from the fuel system • No fuel in the fuel tank • Fuel filter restriction 	<ul style="list-style-type: none"> • If the battery power is low, recharge or replace the battery. • If the starter has failed, repair or replace. • If the connections are loose or corroded, clean and tighten. • Preheat the engine or warm up coolant. (Pour some hot water into the cooling system.) • Thoroughly bleed air. • Refuel. • Clean or replace the fuel filter.
Engine stalls.	<ul style="list-style-type: none"> • No fuel in the fuel tank • Air in the fuel system 	<ul style="list-style-type: none"> • Refuel. • Re-tighten connections and bleed.
Low engine oil pressure (Engine oil pressure indicator comes on)	<ul style="list-style-type: none"> • Insufficient engine oil • Oil leak at connections • Oil pressure switch failure 	<ul style="list-style-type: none"> • Add oil. • Repair. • Replace.
Engine knocks or runs irregularly.	<ul style="list-style-type: none"> • Fuel filter restriction • Air in the fuel system • Air cleaner restriction 	<ul style="list-style-type: none"> • Clean or replace the filter. • Re-tighten connections and bleed. • Clean or replace the element.
Engine overheats	<ul style="list-style-type: none"> • Insufficient coolant and/or coolant leak • Loose fan belt or oil on fan belt • Radiator fins are clogged or bent • Thermostat failure 	<ul style="list-style-type: none"> • Add coolant. Repair leak. • Adjust or replace the fan belt. • Clean and/or repair. • Replace.

2. Electrical System

Trouble	Cause	Solution
Starter does not rotate.	<ul style="list-style-type: none"> • Harness failure • Low battery power • Loose or corroded battery connections • Key switch failure 	<ul style="list-style-type: none"> • Inspect and repair. • Charge the battery. • Clean and tighten. • Replace.
Alternator indicator does not go off after engine is started.	<ul style="list-style-type: none"> • Alternator failure • Harness failure 	<ul style="list-style-type: none"> • Replace • Inspect and repair.
Monitor indicators do not come on or gauges do not operate.	<ul style="list-style-type: none"> • Blown fuse • Sensor failure • Harness failure • Burned indicator bulb(s) 	<ul style="list-style-type: none"> • Replace • Replace • Inspect and repair. • Replace
Travel mode does not shift from fast mode to slow mode and/or vice versa.	<ul style="list-style-type: none"> • Shift switch failure • Harness failure • Switch valve failure 	<ul style="list-style-type: none"> • Replace • Inspect and repair. • Replace

TROUBLESHOOTING

3. Hydraulic System

Trouble	Cause	Solution
Insufficient power: all actuators	<ul style="list-style-type: none"> • Insufficient engine power • Excessively worn hydraulic pump • Main relief valve failure • Hydraulic oil is low. • Suction filter restriction 	<ul style="list-style-type: none"> • Inspect and repair. • Replace. • Re-adjust pressure setting, or replace. • Add hydraulic oil. • Clean or replace.
Insufficient power: front attachment	<ul style="list-style-type: none"> • Failure or incorrect pressure setting of main or pilot relief valve • Damaged hydraulic cylinder packing • Damaged cylinder piston or cylinder tube 	<ul style="list-style-type: none"> • Re-adjust pressure setting, or replace. • Replace cylinder packing. • Replace cylinder piston, cylinder tube, or the cylinder.
Machine does not travel smoothly.	<ul style="list-style-type: none"> • Too tight track (sag) • Foreign matter, such as rocks, stuck in the tracks • Counterbalance valve failure • Travel motor performance drop 	<ul style="list-style-type: none"> • Adjust track sag. • Remove foreign matter. • Replace. • Replace.
Machine mistracks	<ul style="list-style-type: none"> • Track sag is not equal on both sides • Hydraulic pump performance drop • Oil leak inside control valve 	<ul style="list-style-type: none"> • Adjust track sag properly (and equally on both sides). • Replace. • Replace the control valve.
Insufficient swing power or jerky upperstructure swing	<ul style="list-style-type: none"> • Hydraulic pump performance drop • Low pressure valve setting • Swing motor performance drop • Swing bearing seizure • Foreign matter sticking in brake valve • Oil leak inside control valve 	<ul style="list-style-type: none"> • Replace. • Adjust pressure setting, or replace. • Replace. • Lubricate or replace swing bearing. • Clean the brake valve. • Replace the control valve.

 **NOTE:** Contact your authorized dealer for any inspection, adjustment, repair, and/or replacement as required.

SPECIFICATIONS

SPECIFICATIONS

ZAXIS30, 35

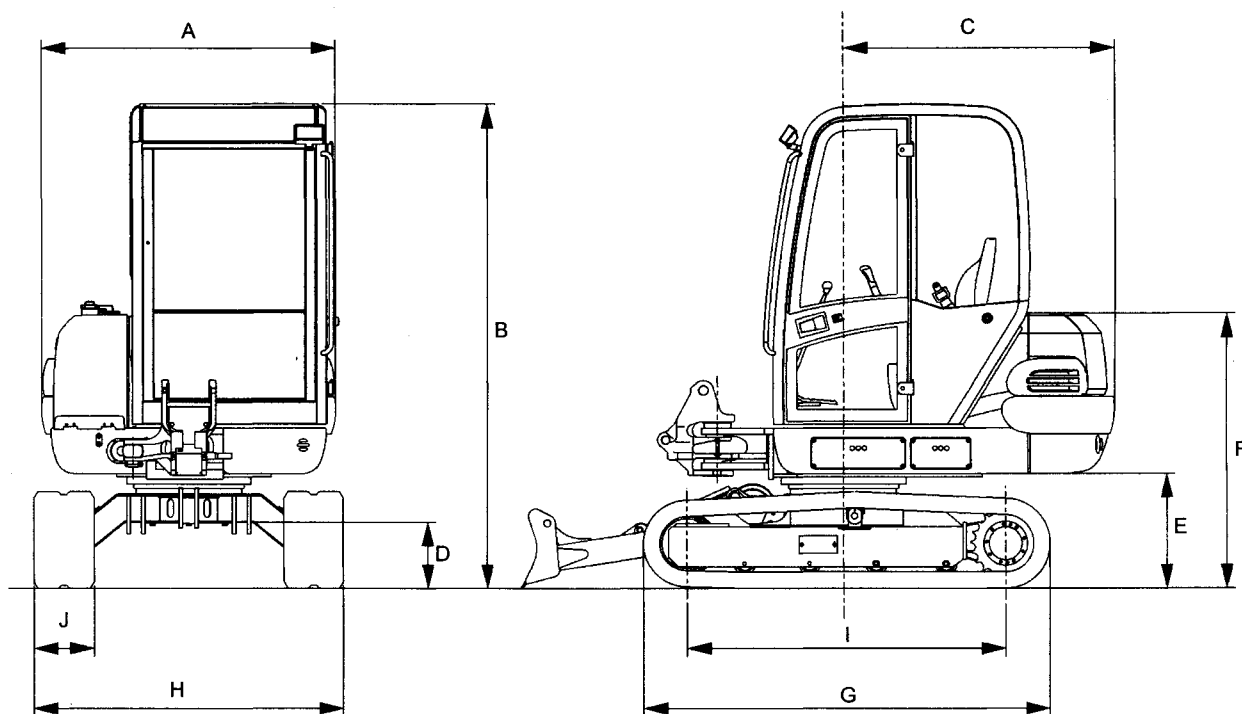

M1LS-12-001

Type	ZAXIS30		ZAXIS35		
	Canopy	Cab	Canopy	Cab	
Type of Front-End Attachment	Boom Swing Type		Boom Swing Type		
Bucket Capacity (Heaped)	m ³ (yd ³) PCSA 0.092 (0.12) CECE 0.08		PCSA 0.11 (0.14) CECE 0.10		
Operating Weight	kg (lb) 2880 (6350) 2960 (6530)		3110 (6860) 3190 (7030)		
Basic Machine Weight	kg (lb) 2070 (4560) 2150 (4740)		2240 (4940) 2320 (5110)		
Engine	Kubota V1505 kW/min ⁻¹ (PS/rpm) 19.9/2300 (27.1/2300)				
A: Overall Width	mm (ft in) 1470 (4'10")				
B: Canopy Cab Height	mm (ft in) 2420 (7'11")				
C: Rear-End Swing Radius	mm (ft in) 1370 (4'6")		1390 (4'7")		
D: Minimum Ground Clearance	mm (ft in) *330 (1'1")				
E: Counterweight Clearance	mm (ft in) *575 (1'11")				
F: Engine Cover Height	mm (ft in) *1370 (4'6")				
G: Undercarriage Length	mm (ft in) 2030 (6'8")				
H: Undercarriage Width	mm (ft in) 1550 (5'1")				
I: Sprocket Center to Idler Center	mm (ft in) 1600 (5'3")				
J: Track Shoe Width	mm (ft in) 300 (11.8") (Rubber Crawler)				
Ground Pressure	kPa (kgf/cm ² , psi)	26 (0.27, 3.7)	27 (0.28, 3.8)	28 (0.29, 4.2)	29 (0.30, 4.3)
Swing Speed	min ⁻¹ (rpm) 8.8 (8.8)				
Travel Speed (fast/slow)	km/h (mph) 4.3/2.9 (2.7/1.8)				
Gradeability	(tan θ) 58% (30°)				

NOTE: * The dimensions do not include the height of the shoe lug.

SPECIFICATIONS

SPECIFICATIONS

ZAXIS40, 50

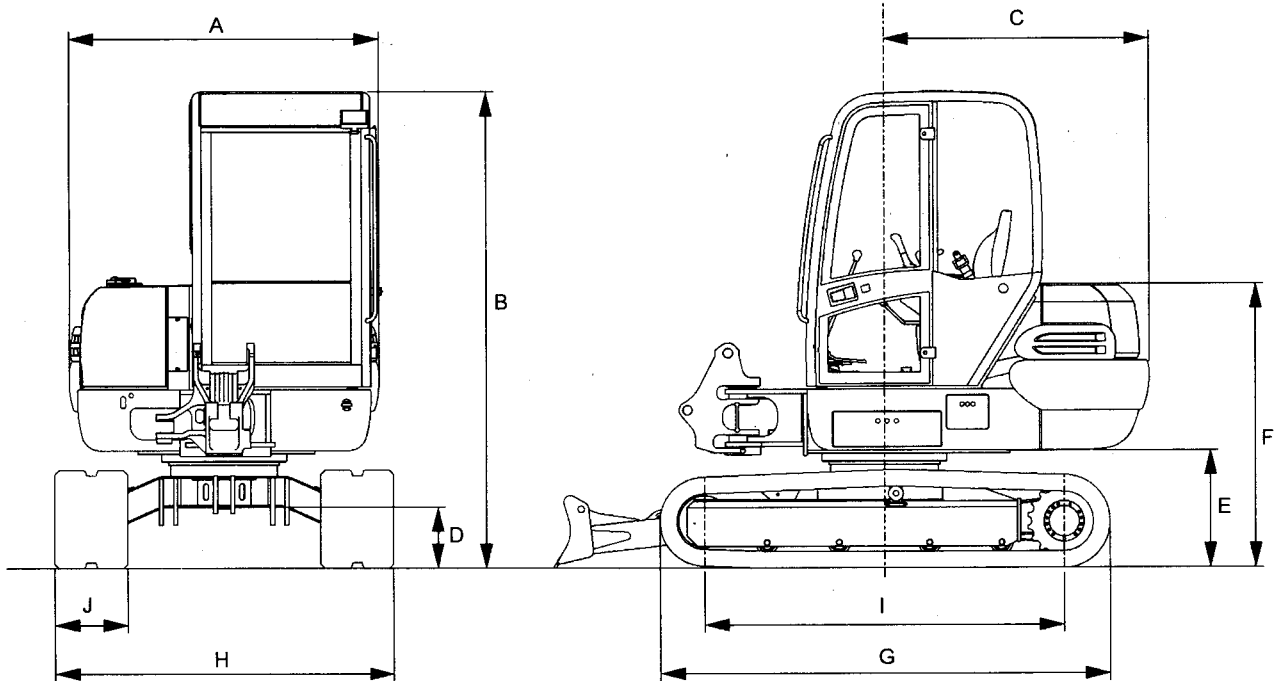

M1LS-12-002

Type	ZAXIS40		ZAXIS50	
	Canopy	Cab	Canopy	Cab
Type of Front-End Attachment	Boom Swing Type			
Bucket Capacity (Heaped)	PCSA 0.14 (0.18) CECE 0.13		PCSA 0.16 (0.21) CECE 0.14	
Operating Weight	4130 (9110)	4210 (9280)	4430 (9770)	4510 (9940)
Basic Machine Weight	2920 (6440)	3000 (6610)	3180 (7010)	3260 (7190)
Engine	Kubota V2203			
	26.5/2100 (36.0/2100)			
A: Overall Width	1690 (5'7")			
B: Canopy Cab Height	2590 (8'6")			
C: Rear-End Swing Radius	1450 (4'9")			
D: Minimum Ground Clearance	*335 (1.1")			
E: Counterweight Clearance	*640 (2'1")			
F: Engine Cover Height	*1540 (5'1")			
G: Undercarriage Length	2450 (8'1")			
H: Undercarriage Width	1850 (6'1")			
I: Sprocket Center to Idler Center	1960 (6'5")			
J: Track Shoe Width	400 (1'4") (Rubber Crawler)			
Ground Pressure	23 (0.24, 3.4)	24 (0.25, 3.6)	25 (0.26, 3.7)	26 (0.27, 3.8)
Swing Speed	9.3 (9.3)			
Travel Speed (fast/slow)	4.4/2.5 (2.7/1.6)			
Gradeability	58% (30°)			

NOTE: * The dimensions do not include the height of the shoe lug.

SPECIFICATIONS

WORKING RANGES

ZAXIS30, 35

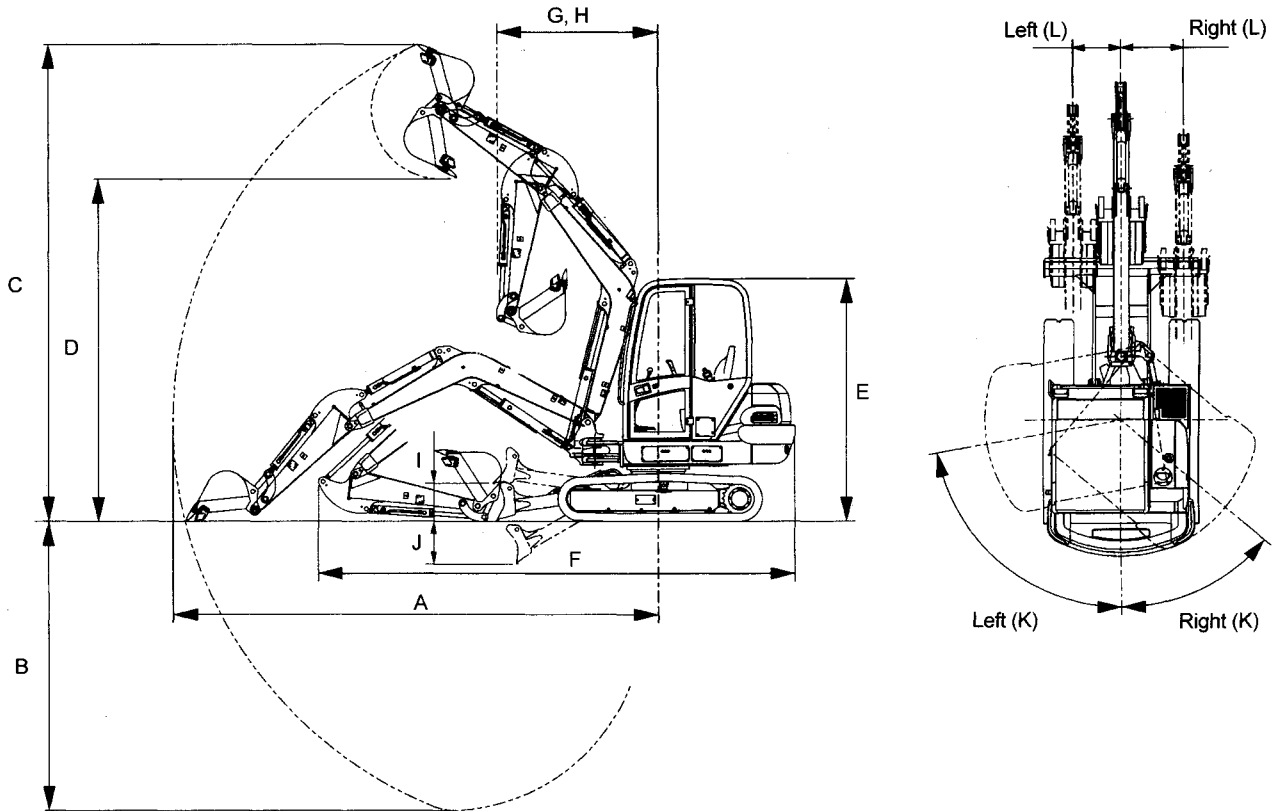

M1LS-12-003

Item	Category	ZAXIS30				ZAXIS35			
		Canopy, Cab		Canopy, Cab		Canopy, Cab		Canopy, Cab	
		1.27 m (4 ft 2 in)	1.57 m (5 ft 2 in)	1.35 m (4 ft 5 in)	1.70 m (5 ft 7 in)	Arm	Arm	Arm	Arm
A: Maximum Digging Reach	mm (ft·in)	4840 (15'11")	5100 (16'9")	5180 (17'0")	5500 (18'0")				
B: Maximum Digging Depth	mm (ft·in)	2890 (9'6")	3190 (10'6")	3100 (10'2")	3450 (11'4")				
C: Maximum Cutting Height	mm (ft·in)	4620 (15'2")	4770 (15'8")	5050 (16'7")	5280 (17'4")				
D: Maximum Dumping Height	mm (ft·in)	3300 (10'10")	3440 (11'3")	3680 (12'1")	3900 (12'10")				
E: Transport Height	mm (ft·in)	2420 (7'11")	2420 (7'11")	2420 (7'11")	2420 (7'11")				
F: Overall Transport Length	mm (ft·in)	4760 (15'7")	4790 (15'7")	4980 (16'4")	5080 (16'8")				
G: Minimum Swing Radius	mm (ft·in)	1730 (5'8")	1800 (5'11")	1730 (5'8")	1760 (5'9")				
H: Minimum Swing Radius with Maximum Boom-Swing Angle	mm (ft·in)	1380 (4'6")	1460 (4'9")	1380 (4'6")	1410 (4'8")				
I: Blade Bottom Highest Position (above ground level)	mm (ft·in)	380 (1'3")	380 (1'3")	380 (1'3")	380 (1'3")				
J: Blade Bottom Lowest Position (below ground level)	mm (ft·in)	430 (1'5")	430 (1'5")	430 (1'5")	430 (1'5")				
K: Maximum Boom-Swing Angle		L80°/R50°		L80°/R50°		L80°/R50°		L80°/R50°	
L: Offset Distance	mm (ft·in)	L480 R620	(L 1'7") (R 1'20")	L480 R620	(L 1'7") (R 1'20")	L480 R620	(L 1'7") (R 1'20")	L480 R620	(L 1'7") (R 1'20")

NOTE: "E: Transport height" includes the height of shoe lug. Other dimensions do not include the height of the shoe lug.

SPECIFICATIONS

WORKING RANGES

ZAXIS40, 50

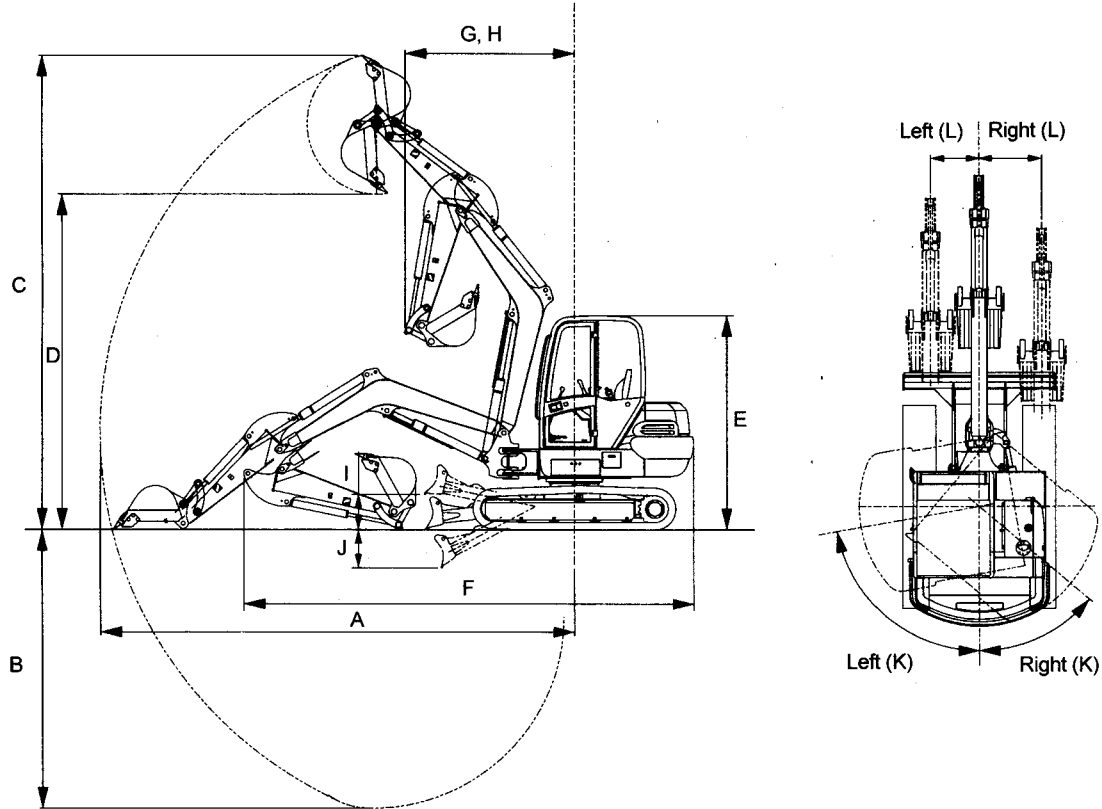

MILS-12-004

Item	Category	ZAXIS40		ZAXIS50					
		Canopy, Cab		Canopy, Cab					
		1.46 m (4 ft 9 in) Arm	1.81 m (5 ft 11 in) Arm	1.50 m (4 ft 11 in) Arm	1.85 m (6 ft 1 in) Arm				
A: Maximum Digging Reach	mm (ft·in)	5730 (18'10")	6060 (19'11")	5920 (19'5")	6240 (20'6")				
B: Maximum Digging Depth	mm (ft·in)	3360 (11'0")	3710 (12'2")	3570 (11'9")	3920 (12'10")				
C: Maximum Cutting Height	mm (ft·in)	5730 (18'10")	5980 (19'7")	5820 (19'1")	6050 (19'10")				
D: Maximum Dumping Height	mm (ft·in)	4050 (13'3")	4300 (14'1")	4150 (13'7")	4380 (14'4")				
E: Transport Height	mm (ft·in)	2590 (8'6")	2590 (8'6")	2590 (8'6")	2590 (8'6")				
F: Overall Transport Length	mm (ft·in)	5450 (17'10")	5490 (18'0")	5590 (18'4")	5680 (18'8")				
G: Minimum Swing Radius	mm (ft·in)	2040 (6'8")	2310 (7'7")	2040 (6'8")	2310 (7'7")				
H: Minimum Swing Radius with Maximum Boom-Swing Angle	mm (ft·in)	1640 (5'5")	1880 (6'2")	1630 (5'4")	1870 (6'2")				
I: Blade Bottom Highest Position (above ground level)	mm (ft·in)	430 (1'5")	430 (1'5")	430 (1'5")	430 (1'5")				
J: Blade Bottom Lowest Position (below ground level)	mm (ft·in)	460 (1'6")	460 (1'6")	460 (1'6")	460 (1'6")				
K: Maximum Boom-Swing Angle		L80°/R50°	L80°/R50°	L80°/R50°	L80°/R50°				
L: Offset Distance	mm (ft·in)	L590 R760	(L 1'7") (R 2'6")	L590 R760	(L 1'7") (R 2'6")	L590 R760	(L 1'11") (R 2'6")	L590 R760	(L 1'11") (R 2'6")

NOTE: "E: Transport height" includes the height of shoe lug. Other dimensions do not include the height of the shoe lug.

SPECIFICATIONS

SHOE TYPES AND APPLICATIONS

ZAXIS30 (Canopy)

Shoe Width	300 mm (12") Steel Tracks	300 mm (12") Rubber Tracks	400 mm (16") Steel Tracks
Application	For Ordinary Ground (Option)	For Paved Road (Standard)	For Weak Footing (Option)
Operating Weight kg (lb)	2950 (6500)	2880 (6350)	3050 (6720)
Counterweight Clearance mm (in)	*560 (1'10")	575 (1'11")	*560 (1'10")
Undercarriage Length mm (ft-in)	2030 (6'8")	2030 (6'8")	2030 (6'8")
Undercarriage Width mm (ft-in)	1550 (5'1")	1550 (5'1")	1650 (5'5")
Ground Pressure kPa (kgf/cm ² , psi)	28.0 (0.28, 4.1)	27.0 (0.27, 4.0)	21.0 (0.22, 3.1)

ZAXIS30 (Cab)

Shoe Width	300 mm (12") Steel Tracks	300 mm (12") Rubber Tracks	400 mm (16") Steel Tracks
Application	For Ordinary Ground (Option)	For Paved Road (Standard)	For Weak Footing (Option)
Operating Weight kg (lb)	3030 (6680)	2960 (6530)	3130 (6900)
Counterweight Clearance mm (in)	*560 (1'10")	575 (1'11")	*560 (1'10")
Undercarriage Length mm (ft-in)	2030 (6'8")	2030 (6'8")	2030 (6'8")
Undercarriage Width mm (ft-in)	1550 (5'1")	1550 (5'1")	1650 (5'5")
Ground Pressure kPa (kgf/cm ² , psi)	28.0 (0.28, 4.1)	28.0 (0.28, 4.1)	22.0 (0.22, 3.2)

 **NOTE:** The specifications for the front-end attachment are for 1.27 m (4 ft 2 in) arm with ISO 0.092 m³ bucket.
 * The dimensions do not include the height of the shoe lug.
 Do not use the machine with rubber shoe on gravel or rocky ground.

SPECIFICATIONS

SHOE TYPES AND APPLICATIONS

ZAXIS35 (Canopy)

Shoe Width	300 mm (12") Steel Tracks	300 mm (12") Rubber Tracks	400 mm (16") Steel Tracks
Application	For Ordinary Ground (Option)	For Paved Road (Standard)	For Weak Footing (Option)
Operating Weight kg (lb)	3180 (6990)	3110 (6830)	3280 (7210)
Counterweight Clearance mm (ft-in)	*560 (1'10")	575 (1'11")	*560 (1'10")
Undercarriage Length mm (ft-in)	2030 (6'8")	2030 (6'8")	2030 (6'8")
Undercarriage Width mm (ft-in)	1550 (5'1")	1550 (5'1")	1650 (5'5")
Ground Pressure kPa (kgf/cm ² , psi)	29.0 (0.30, 4.3)	29.0 (0.30, 4.3)	23.0 (0.23, 3.3)

ZAXIS35 (Cab)

Shoe Width	300 mm (12") Steel Tracks	300 mm (12") Rubber Tracks	400 mm (16") Steel Tracks
Application	For Ordinary Ground (Option)	For Paved Road (Standard)	For Weak Footing (Option)
Operating Weight kg (lb)	3260 (7190)	3190 (7030)	3360 (7410)
Counterweight Clearance mm (ft-in)	*560 (1'10")	575 (1'11")	*560 (1'10")
Undercarriage Length mm (ft-in)	2030 (6'8")	2030 (6'8")	2030 (6'8")
Undercarriage Width mm (ft-in)	1550 (5'1")	1550 (5'1")	1650 (5'5")
Ground Pressure kPa (kgf/cm ² , psi)	30.0 (0.31, 4.4)	30.0 (0.31, 4.4)	24.0 (0.24, 3.4)

 **NOTE:** The specifications for the front-end attachment are for 1.35 m (4 ft 5 in) arm with ISO 0.11 m³ bucket.
 * The dimensions do not include the height of the shoe lug.
 Do not use the machine with rubber shoe on gravel or rocky ground.

SPECIFICATIONS

SHOE TYPES AND APPLICATIONS

ZAXIS40 (Canopy)

Shoe Width	400 mm (16") Steel Tracks	400 mm (16") Rubber Tracks	550 mm (22") Steel Tracks
Application	For Ordinary Ground (Option)	For Paved Road (Standard)	For Weak Footing (Option)
Operating Weight kg (lb)	4280 (9440)	4130 (9110)	4470 (9850)
Counterweight Clearance mm (ft-in)	*625 (2'1")	640 (2'1")	*625 (2'1")
Undercarriage Length mm (ft-in)	2450 (8'0")	2450 (8'0")	2450 (8'0")
Undercarriage Width mm (ft-in)	1850 (6'1")	1850 (6'1")	2000 (6'7")
Ground Pressure kPa (kgf/cm ² , psi)	25.0 (0.26, 3.6)	24.0 (0.24, 3.5)	19.0 (0.19, 2.7)

ZAXIS40 (Cab)

Shoe Width	400 mm (16") Steel Tracks	400 mm (16") Rubber Tracks	550 mm (22") Steel Tracks
Application	For Ordinary Ground (Option)	For Paved Road (Standard)	For Weak Footing (Option)
Operating Weight kg (lb)	4360 (9610)	4210 (9280)	4550 (10000)
Counterweight Clearance mm (ft-in)	*625 (2'1")	640 (2'1")	*625 (2'1")
Undercarriage Length mm (ft-in)	2450 (8'0")	2450 (8'0")	2450 (8'0")
Undercarriage Width mm (ft-in)	1850 (6'1")	1850 (6'1")	2000 (6'7")
Ground Pressure kPa (kgf/cm ² , psi)	25.0 (0.26, 3.6)	24.0 (0.24, 3.5)	19.0 (0.19, 2.8)

 **NOTE:** The specifications for the front-end attachment are for 1.46 m (4 ft 9 in) arm with ISO 0.14 m³ bucket.
 * The dimensions do not include the height of the shoe lug.
 Do not use the machine with rubber shoe on gravel or rocky ground.

SPECIFICATIONS

SHOE TYPES AND APPLICATIONS

ZAXIS50 (Canopy)

Shoe Width	400 mm (16") Steel Tracks	400 mm (16") Rubber Tracks	550 mm (22") Steel Tracks
Application	For Ordinary Ground (Option)	For Paved Road (Standard)	For Weak Footing (Option)
Operating Weight kg (lb)	4580 (10100)	4430 (9770)	4770 (10500)
Counterweight Clearance mm (ft.in)	*625 (2'1")	640 (2'1")	*625 (2'1")
Undercarriage Length mm (ft.in)	2450 (8'0")	2450 (8'0")	2450 (8'0")
Undercarriage Width mm (ft.in)	1850 (6'1")	1850 (6'1")	2000 (6'7")
Ground Pressure kPa (kgf/cm ² , psi)	25.9 (0.26, 3.7)	25.4 (0.26, 3.7)	19.7 (0.20, 2.8)

ZAXIS50 (Cab)

Shoe Width	400 mm (16") Steel Tracks	400 mm (16") Rubber Tracks	550 mm (22") Steel Tracks
Application	For Ordinary Ground (Option)	For Paved Road (Standard)	For Weak Footing (Option)
Operating Weight kg (lb)	4660 (10300)	4510 (9940)	4850 (10700)
Counterweight Clearance mm (in)	*625 (2'1")	640 (2'1")	*625 (2'1")
Undercarriage Length mm (ft.in)	2450 (8'0")	2450 (8'0")	2450 (8'0")
Undercarriage Width mm (ft.in)	1850 (6'1")	1850 (6'1")	2000 (6'7")
Ground Pressure kPa (kgf/cm ² , psi)	27.0 (0.27, 3.9)	26.0 (0.26, 3.8)	20.0 (0.21, 2.9)

 **NOTE:** The specifications for the front-end attachment are for 1.50 m (4 ft 9 in) arm with ISO 0.16 m³ bucket.
 * The dimensions do not include the height of the shoe lug.
 Do not use the machine with rubber shoe on gravel or rocky ground.

SPECIFICATIONS

BUCKET TYPES AND APPLICATIONS

IMPORTANT:

- Select a proper bucket from the list below. Using an oversized or specialty type bucket different from those listed in the table below may cause reduced machine stability during operation.
- At the same time, abnormal loads may be exerted on the machine, front attachment, and/or cylinders, resulting in damage and/or unnecessary repairs. Never use a bucket other than those recommended in the table below.

ZAXIS30

Bucket	Bucket Capacity m ³ (yd ³) ISO (Heaped)	Bucket Width mm		Front-End Attachment	
		(With side cutter) mm (in)	(Without side cutter) mm (in)	1.27 m (4'2") Arm	1.57 m (5'2") Arm
Hoe Bucket	0.055 (0.072)	350 (14")	300 (12")	⊙	⊙
	0.065 (0.085)	400 (16")	350 (14")	⊙	⊙
	0.08 (0.105)	450 (18")	400 (16")	⊙	⊙
	0.09 (0.118)	500 (20")	450 (18")	⊙	○
	0.10 (0.131)	550 (22")	500 (20")	○	□
	0.11 (0.144)	600 (24")	550 (22")	□	□

ZAXIS35

Bucket	Bucket Capacity m ³ (yd ³) ISO (Heaped)	Bucket Width mm		Front-End Attachment	
		(With side cutter) mm (in)	(Without side cutter) mm (in)	1.35 m (4'5") Arm	1.70 m (5'7") Arm
Hoe Bucket	0.055 (0.072)	350 (14")	300 (12")	⊙	⊙
	0.065 (0.085)	400 (16")	350 (14")	⊙	⊙
	0.08 (0.105)	450 (18")	400 (16")	⊙	⊙
	0.09 (0.118)	500 (20")	450 (18")	⊙	⊙
	0.10 (0.131)	550 (22")	500 (20")	⊙	⊙
	0.11 (0.144)	600 (24")	550 (22")	⊙	○
	0.13 (0.170)	650 (26")	600 (24")	○	□

 **NOTE:** (1) Symbols in the above table have the following meanings.

- ⊙: General excavating
- : Light duty excavating
- : Loading work

(2) Hoe bucket is applicable to the following types of work.

General excavating:

For digging and loading operation of sand, gravel, clay, ordinary earth and so on.

Light duty excavating:

For digging loading operation of dried, loosened earth, sand, mud so on.

Their bulk density shall be less than 1600 kg/m³ as a standard.

For loading operation of dried, loosened earth and sand.

Their bulk density shall be less than 1100 kg/m³ as a standard.

SPECIFICATIONS

BUCKET TYPES AND APPLICATIONS

IMPORTANT:

• Select a proper bucket from the list below. Using an oversized or specialty type bucket different from those listed in the table below may cause reduced machine stability during operation.

• At the same time, abnormal loads may be exerted on the machine, front attachment, and/or cylinders, resulting in damage and/or unnecessary repairs. Never use a bucket other than those recommended in the table below.

ZAXIS40

Bucket	Bucket Capacity m ³ (yd ³) ISO (Heaped)	Bucket Width mm		Front-End Attachment	
		(With side cutter) mm (in)	(Without side cutter) mm (in)	1.46 m (4'9") Arm	1.81 m (5'11") Arm
Hoe Bucket	0.10 (0.131)	450 (18")	405 (16")	⊙	⊙
	0.11 (0.144)	500 (20")	455 (18")	⊙	⊙
	0.13 (0.170)	550 (22")	505 (20")	⊙	⊙
	0.14 (0.183)	600 (24")	555 (22")	⊙	○
	0.16 (0.209)	650 (26")	605 (24")	○	□
	0.17 (0.222)	700 (28")	655 (26")	□	□

ZAXIS50

Bucket	Bucket Capacity m ³ (yd ³) ISO (Heaped)	Bucket Width mm		Front-End Attachment	
		(With side cutter) mm (in)	(Without side cutter) mm (in)	1.50 m (4'11") Arm	1.85 m (6'1") Arm
Hoe Bucket	0.10 (0.131)	450 (18")	405 (16")	⊙	⊙
	0.11 (0.144)	500 (20")	455 (18")	⊙	⊙
	0.13 (0.170)	550 (22")	505 (20")	⊙	⊙
	0.14 (0.183)	600 (24")	555 (22")	⊙	⊙
	0.16 (0.209)	650 (26")	605 (24")	○	○
	0.17 (0.222)	700 (28")	655 (26")	□	□

 **NOTE:** (1) Symbols in the above table have the following meanings.

- ⊙: General excavating
- : Light duty excavating
- : Loading work

(2) Hoe bucket is applicable to the following types of work.

General excavating:

For digging and loading operation of sand, gravel, clay, ordinary earth and so on.

Light duty excavating:

For digging loading operation of dried, loosened earth, sand, mud so on.

Their bulk density shall be less than 1600 kg/m³ as a standard.

For loading operation of dried, loosened earth and sand.

Their bulk density shall be less than 1100 kg/m³ as a standard.

SPECIFICATIONS

NOISE LEVEL RESULTS (2000/14/CE, art. VI)

	Cab		Canopy	
	LWA(dBA)	LPA(dBA)	LWA(dBA)	LPA(dBA)
ZAXIS30				
ZAXIS35				
ZAXIS40				
ZAXIS50				

LPA=Noise level at operator ear
LWA=Guaranteed sound power level

SPECIFICATIONS

SPECIAL SPECIFICATION (OPTIONAL)

⚠ CAUTION: The standard machine is not suitable for craning (hooking) or object handling (hydraulic breaker, grapple, etc.) and therefore it is not allowed to do so.

An attachment on the market may cause serious trouble, failure or danger because of unsuitability for the machine.

But an attachment may be possible for use with following conditions, if its specification and suitability for the machine (hydraulic system, stability strength, heat balance, etc.) has been evaluated by test or actual results.

Consult your dealer for more detail.

(1) Allowable Lift Capacity (with Short Arm, Standard Bucket)

Model	Allowable lift capacity at hook on bucket
ZAXIS30	120 kg (260 lb)
ZAXIS35	150 kg (330 lb)
ZAXIS40	200 kg (440 lb)
ZAXIS50	200 kg (440 lb)

(2) Allowable Object Handling Capacity (with Short Arm, Without Bucket).

Model	Allowable lift capacity at hook on bucket	max. pressure	max. flow
ZAXIS 30	200 kg (440 lb)	20.6 MPa (210kgf/cm ²)	63 L/min (16.6 US gal/min)
ZAXIS 35	200 kg (440 lb)	20.6 MPa (210kgf/cm ²)	63 L/min (16.6 US gal/min)
ZAXIS 40	300 kg (660 lb)	24.5 MPa (250kgf/cm ²)	76 L/min (20.1 US gal/min)
ZAXIS 50	320 kg (710 lb)	24.5 MPa (250kgf/cm ²)	76 L/min (20.1 US gal/min)

INDEX

A

Adjust the Operator's Seat	S4
Adjusting Bucket Linkage.....	7-53
Adjusting the Operator's Seat	1-12
After Finishing Work.....	5-26
Air Cleaner	7-40
Alternator Indicator.....	1-5
Avoid Abusive Operation.....	5-13
Avoid Applying Heat to Lines Containing Flammable Fluids.....	S25
Avoid Heating Near Pressurized Fluid Lines	S25
Avoid High-Pressure Fluids	S22
Avoid Hitting Blade with Bucket	5-16
Avoid Hitting Blade with Front Attachment.....	5-16
Avoid Injury from Back-Over and Swing Accidents.....	S11
Avoid Injury from Rollaway Accidents.....	S10
Avoid Power Lines	S14
Avoid Striking the Blade into a Rock.....	5-16
Avoid Tipping.....	5-11
Avoid Tipping.....	S13
Avoid Undercutting.....	S12

B

Before Starting Engine	3-1
Beware of Exhaust Fumes.....	S24
Blade and Track Width Control Lever Operation	5-5
Blade Lever	5-4
Boom Cylinder May Hit Track	5-17
Boom-Swing Pedal	5-2
Breaking in a New Machine	2-1
Bucket and Link Pins.....	7-13
Bucket Types and Applications.....	12-9

C

Cab Door Release Button	1-11
Cab Heater.....	1-8
Cab Light.....	1-11
Change Coolant	7-44
Change Engine Oil.....	7-18
Change Hydraulic Oil.....	7-25
Check and Adjust Fan Belt Tension.....	7-43
Check and Adjust Valve Clearance	7-60
Check and Replace Seat Belt	7-60
Check Bucket Teeth.....	7-51
Check Coolant Level.....	7-42
Check Fuel Hoses.....	7-39
Check Fuel Injection Nozzles.....	7-60
Check Hoses and Lines	7-32
Check Hydraulic Oil Level.....	7-23
Check Injection Timing.....	7-61
Check Instruments after Starting	3-2
Check Radiator Cap.....	7-61
Check Starter and Alternator	7-61
Check the Hour Meter Regularly.....	7-2
Check Tightening Torque of Bolts and Nuts	7-62

Check Track Sag (rubber crawler)	7-54
Check Track Sag (steel crawler)	7-57
Check Water Separator	7-38
Clean Radiator.....	7-45
Clean Suction Filter	7-25
Clean the Air Cleaner Element	7-40
COMPONENTS NAME	1-1
Confirm Direction of Machine to be Driven.....	S8
Control Lever (ISO Excavator Pattern).....	5-1
Control Lever Universal Joint	7-16
Coolant Temperature Gauge and Overheat Indicator.....	1-6
Cooling System.....	7-41
Correct Break-In Procedures.....	2-1
Correct Maintenance and Inspection Procedures	7-1

D

Daily Inspection Check List	7-6
Daily Inspection	7-5
Dig with Caution.....	S14
Dispose of Waste Properly	S27
Do Not Use for Craning Operation	S15
Drain Fuel Tank Sump.....	7-37
Drain Hydraulic Tank Sump.....	7-24
Drive Machine Safely.....	S9

E

Electrical Socket	7-50
Electrical System	7-46
Emergency Exit.....	1-10
Emergency Stop Procedure to Lower Front Attachment.....	5-21
Engine Oil Level.....	7-17
Engine Oil Pressure Indicator.....	1-5
Engine Speed Control Lever	3-1
Engine	7-17
Evacuating in Case of Fire	S24

F

Fast Speed Travel Pedal	4-2
Fasten Your Seat Belt.....	S5
Follow Safety Instructions.....	S2
Front Joint Pins.....	7-11
Fuel Gauge and Fuel Level Indicator	1-7
Fuel System.....	7-36

G

Grading Operation	5-13
Greasing	7-11

INDEX

H	
Handle Chemical Products Safely	S27
Handle Fluids Safely – Avoid Fires	S16
Hood and Access Covers	7-4
Hour Meter	1-7
Hydraulic Breaker Operating Tips.....	5-22
Hydraulic System	7-22
I	
INDEX	14-1
Increase Air Pressure in Hydraulic Oil Tank.....	7-28
Inspect Machine	S3
Inspection and Maintenance of Hydraulic Equipment.....	7-22
Install and Remove Extension Blade	5-6
Investigate Job Site Beforehand	S7
J	
Jump Starting	S6
K	
Keep Person Clear from Working Area.....	S12
Keep Riders Off Machine	S6
Key Switch.....	1-4
L	
Lifting the Entire Machine with a Crane	6-5
M	
Maintenance Guide	7-8
Maintenance Under Special Environmental Conditions	7-66
Measure Engine Compression pressure	7-61
Miscellaneous	7-51
Monitor Panel and Switch Panel	1-3
Monitor Panel	1-5
Move and Operate Machine Safely.....	S5
N	
Never Position Bucket Over Anyone.....	S12
Never Undercut a High Bank	S13
Noise Level Results (89/514/EEG).....	12-10
O	
Object Handling --- If Equipped.....	5-15
Often-Replaced Parts.....	7-65
Opening and Closing Front Window	1-9
Operate Only from Operator's Seat	S6
Operate the Machine Safely.....	5-18
Operate with Caution	S14
Operating Backhoe	5-12
Operating Hydraulic Crusher	5-25
Operating in Water or Mud.....	4-6
Operating on Soft Ground.....	4-4
Operating Tips.....	5-14
Optional Pedal	5-3
P	
Park Machine Safely.....	S15
Parking and Stopping on a Slope.....	4-8
Parking the Machine.....	4-8
Pedals and Levers	1-2
Periodic Replacement of Parts.....	7-7
Pilot Control Shut-Off Lever.....	5-7
Practice Safe Maintenance.....	S18
Precautions for Front Attachment and Blade Removal.....	7-13
Precautions for Installing Wide Bucket or Special Type Bucket.....	5-17
Precautions for Operations	5-10
Precautions for Transporting Machines with Rubber Tracks	6-3
Precautions for Traveling on Slopes	4-7
Preheat Indicator	1-6
Prepare for Emergencies.....	S2
Prepare Machine for Maintenance	7-3
Prevent Battery Explosions	S26
Prevent Burns	S21
Prevent Fires	S23
Prevent Parts from Flying	S20
Protect Against Falling Stones and Debris.....	S7
Protect Against Flying Debris	S15
Protect Against Noise	S3
Provide Signals for Jobs Involving Multiple Numbers of Machines.....	S8
R	
Raise One Track Using Boom and Arm	4-4
Recognize Safety Information	S1
Remove Paint before Welding or Heating	S25
Removing the Machine From Storage.....	10-2
Replace Bucket.....	7-53
Replace Engine Oil Filters	7-18
Replace Fuel Filter.....	7-38
Replace Hydraulic Oil Tank Filter.....	7-29
Replace Pilot Oil Filter	7-31
Replace Rubber Hoses Periodically.....	S21
Replace Rubber Track.....	7-56
Replacement of Hydraulic Oil and Filter Element.....	5-24
Replacing Fuses.....	7-50
S	
SAFETY SIGNS	S28
Safety Transporting	S17
Seat Belt	1-13
Select Correct Track Shoes.....	5-14
Service Air Conditioning System Safely	S-26
Service Your Machine at Specified Intervals.....	7-2
Shoe Types and Applications	12-6
Special Specification (Optional).....	12-11

INDEX

Specifications	12-1
Starting the Engine	3-2
Stay Clear of Moving Parts	S19
Stopping the Engine	3-4
Store Attachments Safely	S20
Storing the Machine	10-1
Support Machine Properly	S19
Swing Bearing	7-14
Swing Internal Gear	7-15

T

The Brand Names of Recommended Oils and Lubricants	7-10
Tool Box and Operator's Manual Box	1-11
Towing Machine a Short Distance	4-5
Transmission	7-20
Transporting by Road	6-1
Transporting the Machine by Truck	6-1
Travel Levers	4-1
Traveling and Other Cautions	5-20
Traveling	4-3
Troubleshooting	11-1

U

Understand Signal Words	S1
Use Handholds and Steps	S4
Using Booster Batteries	3-3
Using Rubber Crawler	5-19

W

Warming Up in Cold Weather	5-9
Warming Up Operation	5-9
Warn Others of Service Work	S19
Wear Protective Clothing	S3
Wiper/Washer Switch	1-8
Work Light Switch	1-4
Working Ranges	12-3

INDEX

MEMO

A series of horizontal dotted lines for writing a memo.

Hitachi Construction Machinery Co., Ltd.

Head Office : 5-1, Koraku 2-chome, Bunkyo-ku Tokyo 112-0004, Japan



Recycle This publication uses recycled paper

PRINTED IN JAPAN(M) 2003.01

TM-H(HGT-M)